



NIELS LINDNER¹, BERENIKE MASING²

**SAT-Generated Initial Solutions for
Integrated Line Planning and
Turn-Sensitive Periodic Timetabling
with Track Choice**

¹  0000-0002-8337-4387
²  0000-0001-7201-2412

Zuse Institute Berlin
Takustr. 7
14195 Berlin
Germany

Telephone: +49 30 84185-0
Telefax: +49 30 84185-125

E-mail: bibliothek@zib.de
URL: <http://www.zib.de>

ZIB-Report (Print) ISSN 1438-0064
ZIB-Report (Internet) ISSN 2192-7782

SAT-Generated Initial Solutions for Integrated Line Planning and Turn-Sensitive Periodic Timetabling with Track Choice

Niels Lindner^{1,2} and Berenike Masing^{*1}

¹Department Network Optimization, Zuse Institute Berlin, Germany

²Department of Mathematics and Computer Science, Freie Universität Berlin, Germany

SHORT SUMMARY

Periodic timetabling is a challenging planning task in public transport. As safety requirements are crucial, track allocation is indispensable for validating the practical feasibility of a railway timetable. For busy stations with limited capacities, this requires a detailed planning of turn-arounds. It is therefore desirable to integrate timetabling not only with track allocation, but also with vehicle scheduling and line planning. This is captured by the Integrated Line Planning and Turn-Sensitive Periodic Timetabling Problem with Track Choice, whose MIP formulation has been demonstrated to be effective for construction site railway rescheduling, as long as a good quality initial solution is available. In this paper, we discuss how to generate such a solution by extending the SAT formulation of the Periodic Event Scheduling Problem with track choice, track occupation, and minimum service frequency components. The SAT approach is superior to pure MIP on real-world instances of the S-Bahn Berlin network.

Keywords: Periodic Timetabling, Railway Timetabling, Railway Track Allocation, Boolean Satisfiability Problem, Rescheduling, Line Planning

1 INTRODUCTION

The timetable is a key component of a well-functioning public transport system. It is not only important to organise and communicate the service, but it also serves as a base for subsequent planning steps, e.g., vehicle scheduling. In turn, the timetable relies on a line concept. Line planning, timetabling, and vehicle scheduling are typically performed in a sequential order (see, e.g., Bussieck, 1998). This has the great drawback that a decision in a previous step might inhibit high quality solutions in the succeeding step. For example, a timetable might be infeasible if, e.g., turning capacities at a station are insufficient. Therefore, designing a timetable should answer how and where vehicles are supposed to turn, but these are traditionally questions in the realm of vehicle scheduling and line planning. Moreover, in the context of railway timetabling, an allocation of timetabled trips to tracks is necessary to ensure that all safety requirements are met. For periodic timetables, which will be considered throughout this paper, this requires to resolve the *track occupation problem* Masing et al. (2023b). To address these issues, several ideas of integrating line planning, periodic timetabling, vehicle scheduling, and track allocation have been developed (Schöbel, 2017; Schiewe, 2020; Fuchs et al., 2022).

Masing et al. (2023a) present the *Integrated Line Planning and Turn-Sensitive Periodic Timetabling Problem with Track Choice* (LPTT) that covers all these aspects and unifies them by an extension of the *Periodic Event Scheduling Problem* (PESP, Serafini & Ukovich, 1989) with flexible track choice as proposed by Wüst et al. (2019). It has been demonstrated by Masing et al. (2023a) and Lindner et al. (2024) that a mixed-integer programming (MIP) formulation of LPTT is usable in practice: Commercial MIP solvers were able to determine qualitative solutions within a reasonable amount of time for practical applications. However, cold-started instances resulted often in bad quality solutions, whereas warm starts initialised with a decent starting solution could even improve the solution further. In other words, a MIP solver might take a long time to finally reach the quality of a hand-crafted solution, but is still able to improve those solutions. Moreover, certificates of optimality are hard to obtain, due to the weak dual bounds. Lastly, the difficulty of the problem is more dependent on the number of safety constraints than on the size of the input event-activity-network.

Our goal now is to provide a fast way to find qualitative solutions to LPTT. In the past, Boolean satisfiability (SAT) approaches have worked astonishingly well for PESP (Großmann et al., 2012;

Kümmling et al., 2015; Roth, 2019; Borndörfer et al., 2020), as well as its extensions, e.g., with included track choice in an iterative framework (Fuchs et al., 2022), or passenger routing (Gattermann et al., 2016). These insights cannot be used one-to-one in our case however, mainly due to two issues: Feasibility is no issue for LPTT – not scheduling any vehicles is a feasible, albeit trivial solution. Moreover, the track occupation constraints that model safety requirements adequately in periodic timetabling problems have not been considered in previous SAT applications. Nevertheless, we examine how SAT techniques can be applied to our case: We modify our problem slightly by enforcing flow – and thus prohibiting the trivial solution – and propose a SAT encoding for LPTT including track choice, track occupation and minimum service frequency constraints. This allows us to perform two comparative studies on real-world scenarios, where we examine the speedup that a black-box SAT solver can obtain in comparison to a pure MIP approach with a commercial solver.

2 METHODOLOGY

We first recall the Periodic Event Scheduling Problem before proceeding to the track occupation problem. We then discuss the Integrated Line Planning and Turn-Sensitive Periodic Timetabling Problem with Track Choice (LPTT) and its MIP formulation, and present our SAT reformulation.

The Periodic Event Scheduling Problem

The *Periodic Event Scheduling Problem* (PESP) is the standard model for periodic timetabling problems in public transport, originally introduced by Serafini & Ukovich (1989). For an event-activity network \mathcal{N} , a period time $T \in \mathbb{N}_{\geq 3}$, lower and upper bounds $\ell, u \in \mathbb{N}_{\geq 0}^{A(\mathcal{N})}$ with $0 \leq \ell \leq u$, the goal is to find a *periodic timetable*, i.e., to assign values π_i to every event $i \in \mathcal{V}(\mathcal{N})$ such that the *periodic tension* x_{ij} of each activity $(i, j) \in A(\mathcal{N})$ satisfies $x_{ij} \equiv \pi_j - \pi_i \pmod T$ and is within the activity bounds, i.e., $\ell_{ij} \leq x_{ij} \leq u_{ij}$. In the optimisation version, the goal is to find a timetable such that the corresponding weighted tension, i.e., $\sum_{(i,j) \in A(\mathcal{N})} w_{ij} x_{ij}$ for some weight vector $w \in \mathbb{R}^{A(\mathcal{N})}$ is minimised.

The interpretation is that the timetable corresponds to timestamps at which the events occur periodically every T time units. The activities describe the transition from one event to another, e.g., driving between two stations or dwelling at a platform, and the periodic tension models the activity duration. Instead of using the periodic tension, one can equivalently formulate the problem via the *periodic slack* $y = x - \ell$. PESP can easily be described as a MIP by introducing the *periodic offset variables* $p \in \mathbb{Z}^{A(\mathcal{N})}$ to express the modulo relation between periodic timetable and tension:

$$\begin{aligned} \min \quad & \sum_{(i,j) \in A(\mathcal{N})} w_{ij} y_{ij} \\ \text{s.t.} \quad & y_{ij} + \ell_{ij} = \pi_j - \pi_i + T p_{ij} & (i, j) \in A(\mathcal{N}) \\ & 0 \leq y_{ij} \leq u_{ij} - \ell_{ij} & (i, j) \in A(\mathcal{N}) \\ & 0 \leq \pi_i \leq T - 1 & i \in \mathcal{V}(\mathcal{N}) \\ & p_{ij} \in \mathbb{Z} & (i, j) \in A(\mathcal{N}) \end{aligned}$$

The Track Occupation Problem

Basic security requirements can be modelled within the PESP framework by introducing *headway activities* (Liebchen & Möhring, 2007). There are some limitations with this approach however, as this ensures only the separation of *events*, not of *activities*. This is discussed in Masing et al. (2023b) in detail. One way to remedy this issue is to enforce additional constraints on the periodic offsets: Suppose there are two activities (i_1, j_1) and (i_2, j_2) assigned to the same infrastructure point. Let further (j_1, i_2) and (i_2, i_1) be the corresponding headway activities. To exclude simultaneous occurrences of events, it is reasonable to assume that the security bounds are nontrivial, i.e., $\ell_a > 0$ and $u_a < T$ for $a \in \{(i_1, j_1), (i_2, j_2)\}$. By adding the *track occupation constraint*

$$p_{i_1 j_1} + p_{j_1 i_2} + p_{i_2 i_1} = 1 \tag{1}$$

we ensure that the event i_2 occurs outside of the track occupation interval of activity (i_1, j_1) by the following reasoning: Assuming that $0 \leq \ell \leq u < T$, as no two activities with a tension of T or larger can be associated to the same infrastructure point, and using that the π -values are restricted

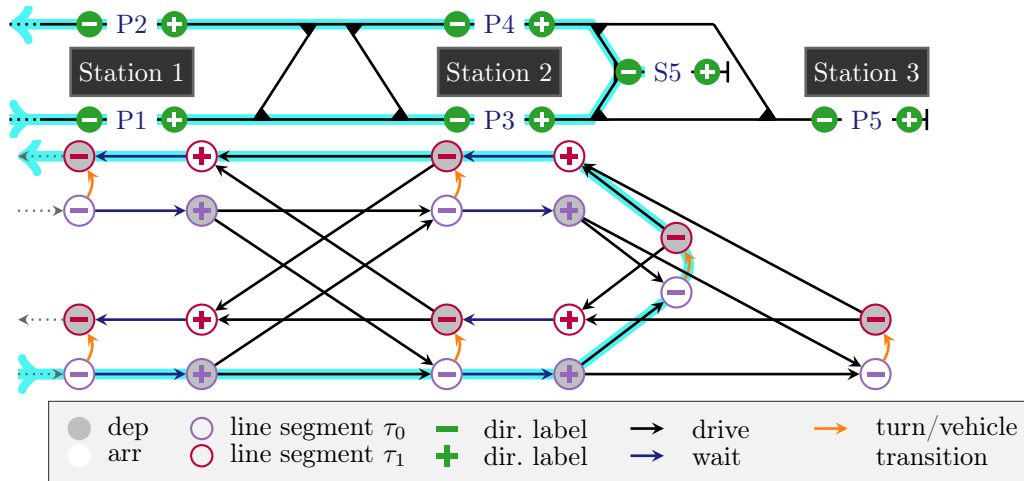

Figure 1: EAN (below) based on the tracks (above) for two line fragments coupled at all possible points. A section of possible vehicle circulation is highlighted in blue.

to $[0, T - 1]$, we have that $p_{ij} \in \{0, 1\}$. More precisely, if $\pi_i \leq \pi_j$, we obtain $p_{ij} = 0$ and $p_{ji} = 1$ otherwise. Consequently, it is guaranteed that exactly one of the following occurs:

$$\pi_{i_1} \leq \pi_{j_1} \leq \pi_{i_2} \quad \text{or} \quad \pi_{j_1} \leq \pi_{i_2} \leq \pi_{i_1} \quad \text{or} \quad \pi_{i_2} \leq \pi_{i_1} \leq \pi_{j_1}.$$

We will denote the set of all pairs $((i_1, j_1), (i_2, j_2))$ of activities that are associated to the same infrastructure point by \mathcal{P} . We further let \mathcal{H} denote the graph consisting of all additional headway activities (j_1, i_2) and (i_1, i_2) for all $((i_1, j_1), (i_2, j_2)) \in \mathcal{P}$.

Integrating Line Planning and Vehicle Scheduling via Track Choice

The *Integrated Line Planning and Turn-Sensitive Periodic Timetabling Problem with Track Choice* (LPTT) has been presented in (Masing et al., 2023a) and without the line planning component in (Masing et al., 2023b). The main player is a *turn-sensitive event-activity network* (EAN) \mathcal{N} that consists of subnetworks for each potential line of a given line pool on a mesoscopic level, i.e., activities are associated to certain infrastructure points, e.g., platforms or siding tracks. These subnetworks are connected by *transition arcs* that reflect vehicle transitions from one line to another. A periodic vehicle schedule then corresponds to a *vehicle circulation*, i.e., a collection of simple directed cycles in \mathcal{N} . A vehicle circulation hence determines an allocation of vehicle trips to a sequence mesoscopic infrastructure points, and a fortiori a line plan on a macroscopic level. An illustrating example is given in Figure 1.

A solution to LPTT is then comprised of a vehicle circulation and a solution to PESP on the restriction of the \mathcal{N} to the activities contained in the vehicle circulation, that additionally obeys all track occupation constraints for all pairs in \mathcal{P} .

MIP Formulation

We consider the following MIP formulation of LPTT (Masing et al., 2023a):

$$\begin{aligned}
\min \quad & \sum_{a \in \mathcal{A}(\mathcal{S})} c_a & (2) \\
\text{s.t.} \quad & y_{ij} + \ell_{ij} h_{ij} = \pi_j - \pi_i + T p_{ij} & (i, j) \in \mathcal{A}(\mathcal{N}) & (3) \\
& y_{ij} \leq u_{ij} - \ell_{ij} + (T-1-u_{ij}+\ell_{ij})(1-h_{ij}) & (i, j) \in \mathcal{A}(\mathcal{N}) & (4) \\
& \sum_{j \in \delta^+(i)} h_{ij} = \sum_{j \in \delta^-(i)} h_{ji} & i \in \mathcal{V}(\mathcal{N}) & (5) \\
& \sum_{j \in \delta^+(i)} h_{ij} \leq 1 & i \in \mathcal{V}(\mathcal{N}) & (6) \\
c_a + \sum_{\substack{(i,j) \in \mathcal{A}(\mathcal{N}): \\ (\sigma(i), \sigma(j))=a}} h_{ij} \geq \bar{f}_a & & a \in \mathcal{A}(\mathcal{S}) & (7) \\
\hline
& \pi_{i_2} - \pi_{i_1} + T p_{i_2 i_1} \leq (T - \delta)(3 - h_{i_1 j_1} - h_{i_2 j_2}) & ((i_1, j_1), (i_2, j_2)) \in \mathcal{P} & (8) \\
& \pi_{i_2} - \pi_{i_1} + T p_{i_2 i_1} \geq \delta(h_{i_1 j_1} + h_{i_2 j_2} - 1) & ((i_1, j_1), (i_2, j_2)) \in \mathcal{P} & (9) \\
& \pi_{j_2} - \pi_{j_1} + T p_{i_2 j_1} \leq (T - \varepsilon)(3 - h_{i_1 j_1} - h_{i_2 j_2}) & ((i_1, j_1), (i_2, j_2)) \in \mathcal{P} & (10) \\
& \pi_{j_2} - \pi_{j_1} + T p_{i_2 j_1} \geq \varepsilon(h_{i_1 j_1} + h_{i_2 j_2} - 1) & ((i_1, j_1), (i_2, j_2)) \in \mathcal{P} & (11) \\
& p_{i_1 j_1} + p_{j_1 i_2} + p_{i_2 i_1} \leq 2(2 - h_{i_1 j_1} - h_{i_2 j_2}) + 1 & ((i_1, j_1), (i_2, j_2)) \in \mathcal{P} & (12) \\
& p_{i_1 j_1} + p_{j_1 i_2} + p_{i_2 i_1} \geq -(2 - h_{i_1 j_1} - h_{i_2 j_2}) + 1 & ((i_1, j_1), (i_2, j_2)) \in \mathcal{P} & (13) \\
\hline
& y_{ij} \geq 0 & (i, j) \in \mathcal{A}(\mathcal{N}) & (14) \\
& c_a \geq 0 & a \in \mathcal{A}(\mathcal{S}) & (15) \\
& p_{ij} \in \{0, 1, 2\} & (i, j) \in \mathcal{A}(\mathcal{N}) & (16) \\
& p_{ij} \in \{0, 1\} & (i, j) \in \mathcal{A}(\mathcal{H}) & (17) \\
& h_{ij} \in \{0, 1\} & (i, j) \in \mathcal{A}(\mathcal{N}) & (18) \\
& 0 \leq \pi_i \leq T - 1 & i \in \mathcal{V}(\mathcal{N}) & (19)
\end{aligned}$$

We briefly explain the key ingredients of this model: The vehicle circulation and hence the track choice in the turn-sensitive EAN \mathcal{N} is modelled by means of the binary variables h_{ij} (18) for each activity $(i, j) \in \mathcal{A}(\mathcal{N})$. The constraints (5) and (6) ensure that the circulation decomposes into simple directed cycles. If $h_{ij} = 1$, then (3), (4), (14), (16), (19) are the classic PESP constraints with $y_{ij} + \ell_{ij} \in [\ell_{ij}, u_{ij}]$. For $h_{ij} = 0$, (3) and (4) turn the activity duration bounds into $y_{ij} \in [0, T - 1]$, which does not impose any restrictions.

The constraints (8)-(13) and (17) resolve the track occupation problems by means of (1) for all pairs of activities $((i_1, j_1), (i_2, j_2)) \in \mathcal{P}$ on the same infrastructure point. They are only activated if both $h_{i_1, j_1} = 1$ and $h_{i_2, j_2} = 1$. The additional headway activities in $\mathcal{A}(\mathcal{H})$ have the bounds $[\delta, T - \delta]$ for activities of the form (i_2, i_1) and $[\varepsilon, T - \varepsilon]$ for (j_1, i_2) .

Finally, (7) in conjunction with the objective (2) and (15) motivate to maximise the number of driving activities $(i, j) \in \mathcal{A}(\mathcal{N})$ that connect a given pair $a = (\sigma(i), \sigma(j))$ of stations. We collect all such pairs of connected stations in a macroscopic graph \mathcal{S} . We assume that there is a *minimum intended service frequency* \bar{f}_a for each $a \in \mathcal{A}(\mathcal{S})$, and punish lower frequencies, but do not reward higher frequencies than \bar{f}_a . This is an incarnation of minimum edge frequency requirements in line planning (see, e.g., Schöbel, 2012). Since the goal of this paper is to find feasible solutions only, we do not introduce other objectives here and refer instead to (Masing et al., 2023a) and (Masing et al., 2023b).

SAT Reformulation

We describe now how to encode the constraints (3)-(19) into a Boolean formula.

Track choice variables and clauses. We start with the track choice variables h_{ij} and model them

by a binary variable with the same name. Flow conservation (5) is modelled by

$$-h_{ik} \vee \bigvee_{j \in \delta^-(i)} h_{ji} \quad i \in \mathcal{V}(\mathcal{N}), k \in \delta^+(i) \quad (20)$$

$$-h_{ki} \vee \bigvee_{j \in \delta^+(i)} h_{ij} \quad i \in \mathcal{V}(\mathcal{N}), k \in \delta^-(i) \quad (21)$$

and the simple cycle constraints (6) by

$$\bigwedge_{\{j,k\} \subseteq \delta^+(i), j \neq k} (-h_{ij} \vee -h_{ik}) \quad i \in \mathcal{V}(\mathcal{N}) \quad (22)$$

$$\bigwedge_{\{j,k\} \subseteq \delta^-(i), j \neq k} (-h_{ji} \vee -h_{ki}) \quad i \in \mathcal{V}(\mathcal{N}) \quad (23)$$

This is different to the modelling used by Fuchs et al. (2022), where the flow variables are based on vertices, not on arcs.

Timetabling variables and clauses. Großmann et al. (2012) have introduced a reformulation of PESP in terms of SAT. Discretising time, a timetable $\pi \in \{0, \dots, T-1\}^{\mathcal{V}(\mathcal{N})}$ is encoded by Boolean variables $t_{i,k}$ for $i \in \mathcal{V}(\mathcal{N})$ and $k \in \{-1, \dots, T-1\}$ such that $t_{i,k}$ is true if and only if $\pi_i \leq k$. This is realised by the following:

$$\neg t_{i,-1} \quad i \in \mathcal{V}(\mathcal{N}) \quad (24)$$

$$t_{i,T-1} \quad i \in \mathcal{V}(\mathcal{N}) \quad (25)$$

$$\neg t_{i,k-1} \vee t_{i,k} \quad i \in \mathcal{V}(\mathcal{N}), k \in \{1, \dots, T-2\} \quad (26)$$

Note that assuming integral values for π is no restriction due to total unimodularity (Odiijk, 1994). For an arc $(i, j) \in \mathcal{A}(\mathcal{N})$, the set of pairs $(\pi_i, \pi_j) \in \{0, \dots, T-1\} \times \{0, \dots, T-1\}$ that violate the activity bounds $[\ell_{ij}, u_{ij}]$ is then covered by a set of rectangles \mathcal{R}_{ij} (Großmann et al., 2012). It is possible to explicitly construct such a covering \mathcal{R}_{ij} with a minimum number of rectangles (Roth, 2019). We obtain the following clauses that translate (3) and (4):

$$\neg h_{ij} \vee \neg t_{i,b_i} \vee t_{i,a_i-1} \vee \neg t_{j,b_j} \vee t_{j,a_j-1} \quad (i, j) \in \mathcal{A}(\mathcal{N}), [a_i, b_i] \times [a_j, b_j] \in \mathcal{R}_{ij} \quad (27)$$

As with the MIP, there is no restriction if h_{ij} is false.

Track occupation variables and clauses. To encode the track occupation constraints (8)-(13), consider a pair $((i_1, i_2), (j_1, j_2)) \in \mathcal{P}$. We first model the additional headway arcs $(j_1, i_2), (i_2, i_1) \in \mathcal{A}(\mathcal{H})$ with their bounds in the same way in the timetabling part by means of the clauses (24)-(26), but adapting (27) by replacing the first literal $\neg h_{ij}$ by $\neg h_{i_1 j_1} \vee \neg h_{i_2 j_2}$.

We then introduce new binary variables q_{ij} for $(i, j) \in \{(i_1, j_1), (j_1, i_2), (i_2, i_1)\}$ with the property that q_{ij} being set to true implies that that $p_{ij} = 0$ for the periodic offset variable p_{ij} (16), (17). As noted before, this is equivalent to $\pi_i \leq \pi_j$. We cover

$$\{(\pi_i, \pi_j) \in \{0, \dots, T-1\} \times \{0, \dots, T-1\} \mid \pi_i \geq \pi_j + 1\}$$

with a set of rectangles $\tilde{\mathcal{R}}_{ij}$, and exclude those rectangles by

$$\neg q_{ij} \vee \neg h_{i_1 j_1} \vee \neg h_{i_2 j_2} \vee \neg t_{i,b_i} \vee t_{i,a_i-1} \vee \neg t_{j,b_j} \vee t_{j,a_j-1} \\ (i, j) \in \{(i_1, j_1), (j_1, i_2), (i_2, i_1)\}, [a_i, b_i] \times [a_j, b_j] \in \tilde{\mathcal{R}}_{ij} \quad (28)$$

To ensure (1), we add the clauses

$$(q_{i_1 j_1} \vee q_{j_1 i_2}) \wedge (q_{j_1 i_2} \vee q_{i_2 i_1}) \wedge (q_{i_2 i_1} \vee q_{i_1 j_1}) \quad (29)$$

that state that at least two q_{ij} must be true and hence at least two p_{ij} are 0. Note that there is no need to couple (29) to the h variables.

Flow induction. By now, we have transformed almost all constraints of the MIP to a Boolean formula – with the exception of the objective-related (7). Setting all h_{ij} to false would however be trivially feasible. We therefore will turn (7) into the hard constraint

$$\sum_{\substack{(i,j) \in \mathcal{A}(\mathcal{N}): \\ (\sigma(i), \sigma(j)) = a}} h_{ij} \geq \bar{f}_a \quad a \in \mathcal{A}(\mathcal{S}) \quad (30)$$

Scenario	SAT		MIP		
	Vars	Clauses	Integer Vars	Cont. Vars	Constraints
BBER-BBU	38 866	176 732	428	443	1 214
BGAS-BKW	107 549	966 483	1 760	1 259	6 126
BBUP	176 305	5 468 063	5 365	1 968	32 422
BBOS-BWIN-BTG	275 639	4 172 538	5 002	3 140	25 324
BBKS-BWT	410 369	41 217 305	14 472	4 007	244 686
BOSB	432 516	31 428 806	19 632	4 244	192 414
BSW	511 612	33 478 214	18 629	5 250	203 884
BGB-BWES	675 946	56 603 646	23 056	7 451	329 658

Table 1: Metrics of the SAT and MIP models for our 8 scenarios showing the number of SAT variables and clauses in conjunctive normal form, the number of integer and continuous MIP variables, and the number of MIP constraints. These are the instances for Test 1, the figures are similar for Test 2.

The rationale is that a public transport planner might have an intuition about what a good minimum service frequency could be, and this is easier to grasp on a macroscopic level. Since we are only interested in a feasible solution to LPTT, any choice of \bar{f}_a serves the purpose, with higher values of \bar{f}_a giving rise to better solutions, but risking infeasibility.

There are several ways in the literature to model the cardinality constraint (30) in terms of a Boolean formula. We choose a sequential counter-based version (Sinz, 2005; Bittner et al., 2019). To this end, let $a \in \mathcal{A}(\mathcal{S})$, and let $\{(i_1, j_1), \dots, (i_{n_a}, j_{n_a})\}$ be the set of arcs $(i, j) \in \mathcal{A}(\mathcal{N})$ with $(\sigma(i), \sigma(j)) = a$. We introduce new binary variables $r_{k,\ell}$ for $k \in \{1, \dots, n_a\}$ and $\ell \in \{1, \dots, n_a - \bar{f}_a\}$ with the interpretation that $r_{k,\ell}$ is true if and only if at least ℓ out of $h_{i_1 j_1}, \dots, h_{i_k j_k}$ are false, and add the following clauses (Sinz, 2005):

$$\neg r_{1,\ell} \quad \ell \in \{2, \dots, n_a - \bar{f}_a\} \quad (31)$$

$$\neg r_{k-1,\ell} \vee r_{k,\ell} \quad k \in \{1, \dots, n_a - 1\}, \ell \in \{1, \dots, n_a - \bar{f}_a\} \quad (32)$$

$$h_{i_k j_k} \vee r_{k,1} \quad k \in \{1, \dots, n_a - 1\} \quad (33)$$

$$h_{i_k j_k} \vee \neg r_{k-1,\ell-1} \vee r_{k,\ell} \quad k \in \{1, \dots, n_a - 1\}, \ell \in \{2, \dots, n_a - \bar{f}_a\} \quad (34)$$

$$h_{i_k j_k} \vee \neg r_{k-1, n_a - \bar{f}_a} \quad k \in \{1, \dots, n_a\} \quad (35)$$

Note that this is only reasonable for $2 \leq \bar{f}_a < n_a$, the other cases can be handled without any difficulties.

This finishes the SAT formulation for LPTT with the additional constraint (30) instead of (7). We will denote this modified problem by $\text{LPTT}_{\bar{f}}$.

3 RESULTS AND DISCUSSION

We finally compare the practical performance of a SAT and a MIP solver with respect to finding an initial solution to $\text{LPTT}_{\bar{f}}$. To this end, we consider 8 scenarios based on real construction sites in the S-Bahn network of Berlin of the years 2021-2023. S-Bahn Berlin operates a suburban rail network with a periodic timetable that repeats every 20 minutes. On the most busy sections, up to 7 trains run per direction within 20 minutes. For planning purposes, the timetable resolution is 0.1 minutes, so that we consider a period time of $T = 200$. Due to construction sites, certain parts of the network become unavailable and the regular timetable cannot be adhered to anymore, calling for the need to reschedule. The size of the part of the network that has to be adjusted varies across our scenarios. Some key size metrics of the SAT and MIP models of the 8 scenarios have been collected in Table 1.

We conduct two sets of experiments with the aim to find good quality feasible solutions for $\text{LPTT}_{\bar{f}}$. In all experiments, we compare our SAT formulation with the MIP formulation making use of a black-box solver. As a SAT solver, we use Cadical 1.9.4 (Biere et al., 2020), which has been decorated at several SAT competitions. Gurobi 10.0.1 (Gurobi Optimization, LLC, 2023) is used as a MIP solver. All computations have been run on an Intel Xeon E3-1270 v6 CPU machine with 32 GB RAM and a wall time limit of one hour.

Scenario	SAT/Cadical	MIP/Gurobi
BBER-BBU	< 1	< 1
BGAS-BKW	< 1	< 1
BBUP	10	349
BBOS-BWIN-BTG	2	2
BBKS-BWT	846	timeout
BOSB	868	timeout
BSW	74	2 170
BGB-BWES	1 406	timeout

Table 2: Results of Test 1: Time until the first feasible solution was found, rounded to full seconds. The wall time limit is 3 600 seconds.

Scenario	SAT/Cadical	MIP/Gurobi	Status
BBER-BBU	< 1	< 1	feasible
BGAS-BKW	< 1	< 1	feasible
BBUP	5	99	infeasible
BBOS-BWIN-BTG	1	< 1	infeasible
BBKS-BWT	14	2	infeasible
BOSB	2 497	timeout	feasible
BSW	198	timeout	infeasible
BGB-BWES	timeout	timeout	unknown

Table 3: Results of Test 2: Time until an (in)feasibility certificate was obtained, rounded to full seconds. The wall time limit is 3 600 seconds.

Test 1: Reduced Service Frequencies

In the first series, we demand that the minimum service frequency is at least the one that has been operated in the actual construction site timetable, but at most the one of the regular annual timetable. In particular, the resulting $LPTT_{\bar{f}}$ instances are always feasible, and the question is which method – SAT or MIP solver – is faster in finding an initial solution.

The results are summarised in Table 2. Despite the fact that the SAT solver is slowed down on small instances due to the enormous number of variables and clauses, SAT is clearly faster than the MIP solver and can find an initial solution for all instances. In contrast, Gurobi is not able to find a feasible solution for 3 instances within the time limit. This is even more remarkable, because Cadical runs on a single thread only and Gurobi can make use of up to 8 threads on our machine.

Test 2: Regular Service Frequencies

In the second set of computational experiments, we set the minimum frequency of all parts of the network that are still available to the one given by the annual timetable. This is mostly – but not always – infeasible, and creates harder instances. The question here is which approach – SAT or MIP solver – detects (in)feasibility faster. Table 3 summarises the results. Again, SAT is typically faster than MIP, with a large advantage for larger instances. One exception is the BBKS-BWT instance, where in fact the root LP is already infeasible. The feasibility or infeasibility of the large BGB-BWES instance, where roughly half of the network is allowed to be replanned, cannot be decided by either method within one hour.

4 CONCLUSIONS

We developed a SAT formulation for the Integrated Line Planning and Turn-Sensitive Periodic Timetabling Problem with Track Choice and a given macroscopic minimum service frequency level. Using a black-box SAT solver boosts performance in finding an initial solution to the $LPTT_{\bar{f}}$ compared to a black-box MIP solver on real-world instances. As in other periodic timetabling applications, SAT turns out to be once more a superior choice for the feasibility question. The success of the SAT approach indicates that it might be worthwhile to investigate a branch-and-bound framework combining both methods to quickly determine optimal LPTT solutions, not only in the context of construction site scenarios.

ACKNOWLEDGEMENTS

We want to thank DB InfraGO AG, Fahrplan und Kapazitätsmanagement S-Bahn Berlin, for providing data and expertise.

REFERENCES

- Biere, A., Fazekas, K., Fleury, M., & Heisinger, M. (2020). CaDiCaL, Kissat, Paracooba, Plingeling and Treengeling entering the SAT Competition 2020. In T. Balyo, N. Froylenks, M. Heule, M. Iser, M. Jarvisalo, & M. Suda (Eds.), *Proc. of SAT Competition 2020 – solver and benchmark descriptions* (Vol. B-2020-1, pp. 51–53). University of Helsinki.
- Bittner, P. M., Thüm, T., & Schaefer, I. (2019). SAT Encodings of the At-Most-k Constraint. In P. C. Ölveczky & G. Salaün (Eds.), *Software Engineering and Formal Methods* (pp. 127–144). Cham: Springer International Publishing. doi: 10.1007/978-3-030-30446-1_7
- Borndörfer, R., Lindner, N., & Roth, S. (2020). A concurrent approach to the periodic event scheduling problem. *Journal of Rail Transport Planning & Management*, 15, 100175. (Best Papers of RailNorrköping 2019) doi: 10.1016/j.jrtpm.2019.100175
- Bussieck, M. (1998). *Optimal Lines in Public Rail Transport* (Unpublished doctoral dissertation). Technische Universität Braunschweig.
- Fuchs, F., Trivella, A., & Corman, F. (2022). Enhancing the interaction of railway timetabling and line planning with infrastructure awareness. *Transportation Research Part C: Emerging Technologies*, 142, 103805. doi: 10.1016/j.trc.2022.103805
- Gattermann, P., Großmann, P., Nachtigall, K., & Schöbel, A. (2016). Integrating Passengers’ Routes in Periodic Timetabling: A SAT approach. In M. Goerigk & R. F. Werneck (Eds.), *16th workshop on algorithmic approaches for transportation modelling, optimization, and systems (atmos 2016)* (Vol. 54, pp. 3:1–3:15). Dagstuhl, Germany: Schloss Dagstuhl – Leibniz-Zentrum für Informatik. doi: 10.4230/OASIcs.ATMOS.2016.3
- Großmann, P., Hölldobler, S., Manthey, N., Nachtigall, K., Opitz, J., & Steinke, P. (2012). Solving Periodic Event Scheduling Problems with SAT. In H. Jiang, W. Ding, M. Ali, & X. Wu (Eds.), *Advanced Research in Applied Artificial Intelligence* (pp. 166–175). Berlin, Heidelberg: Springer. doi: 10.1007/978-3-642-31087-4_18
- Gurobi Optimization, LLC. (2023). *Gurobi Optimizer Reference Manual*. Retrieved from <https://www.gurobi.com>
- Kümmling, M., Großmann, P., Nachtigall, K., Opitz, J., & Weiß, R. (2015). A state-of-the-art realization of cyclic railway timetable computation. *Public Transport*, 7(3), 281–293. doi: 10.1007/s12469-015-0108-5
- Liebchen, C., & Möhring, R. H. (2007). The modeling power of the periodic event scheduling problem: Railway timetables — and beyond. In F. Geraets, L. Kroon, A. Schoebel, D. Wagner, & C. D. Zaroliagis (Eds.), *Algorithmic methods for railway optimization* (pp. 3–40). Berlin, Heidelberg: Springer Berlin Heidelberg.
- Lindner, N., Masing, B., & Liebchen, C. (2024). *Integrierte Baufahrplanoptimierung auf dem Netz der S-Bahn Berlin*. (to appear in: HEUREKA’24 - Optimierung in Verkehr und Transport)
- Masing, B., Lindner, N., & Liebchen, C. (2023a). Integrating Line Planning for Construction Sites into Periodic Timetabling via Track Choice. In D. Frigioni & P. Schiewe (Eds.), *23rd symposium on algorithmic approaches for transportation modelling, optimization, and systems (atmos 2023)* (Vol. 115, pp. 5:1–5:15). Dagstuhl, Germany: Schloss Dagstuhl – Leibniz-Zentrum für Informatik. doi: 10.4230/OASIcs.ATMOS.2023.5
- Masing, B., Lindner, N., & Liebchen, C. (2023b). Periodic timetabling with integrated track choice for railway construction sites. *Journal of Rail Transport Planning & Management*, 28, 100416. doi: 10.1016/j.jrtpm.2023.100416

- Odiijk, M. A. (1994). *Construction of periodic timetables, part 1: A cutting plane algorithm* (Tech. Rep. No. 94-61). TU Delft.
- Roth, S. (2019). *SAT Heuristics for the Periodic Event Scheduling Problem*. (Master thesis, Freie Universität Berlin)
- Schiewe, P. (2020). *Integrated Optimization in Public Transport Planning* (Vol. 160). Cham: Springer International Publishing. doi: 10.1007/978-3-030-46270-3
- Schöbel, A. (2012). Line planning in public transportation: models and methods. *OR Spectrum*, 34(3), 491–510. doi: 10.1007/s00291-011-0251-6
- Schöbel, A. (2017). An eigenmodel for iterative line planning, timetabling and vehicle scheduling in public transportation. *Transportation Research Part C: Emerging Technologies*, 74, 348–365. doi: 10.1016/j.trc.2016.11.018
- Serafini, P., & Ukovich, W. (1989). A Mathematical Model for Periodic Scheduling Problems. *SIAM Journal on Discrete Mathematics*, 2(4), 550–581. doi: 10.1137/0402049
- Sinz, C. (2005). Towards an Optimal CNF Encoding of Boolean Cardinality Constraints. In P. van Beek (Ed.), *Principles and Practice of Constraint Programming - CP 2005* (pp. 827–831). Berlin, Heidelberg: Springer. doi: 10.1007/11564751_73
- Wüst, R., Bütikofer, S., Ess, S., Gomez, C., Steiner, A., Laumanns, M., & Szabo, J. (2019). Improvement of maintenance timetable stability based on iteratively assigning event flexibility in FPESP. In A. Peterson, M. Joborn, & M. Bohlin (Eds.), *RailNorrköping 2019* (pp. 1160–1177). Linköping: Linköping University Electronic Press. doi: 10.21256/zhaw-18282