

Konrad-Zuse-Zentrum
für Informationstechnik Berlin

Takustraße 7
D-14195 Berlin-Dahlem
Germany

RALF BORNDÖRFER MARIKA KARBSTEIN MARC E. PFETSCH

The Steiner Connectivity Problem

Supported by the DFG Research Center MATHEON "Mathematics for key technologies".

ZIB-Report 09-07 (April 2010, revised May 2012)

Herausgegeben vom
Konrad-Zuse-Zentrum für Informationstechnik Berlin
Takustraße 7
D-14195 Berlin-Dahlem

Telefon: 030-84185-0
Telefax: 030-84185-125

e-mail: bibliothek@zib.de
URL: <http://www.zib.de>

ZIB-Report (Print) ISSN 1438-0064
ZIB-Report (Internet) ISSN 2192-7782

The Steiner Connectivity Problem[§]

Ralf Borndörfer* Marika Karbstein* Marc E. Pfetsch**

Abstract

The Steiner connectivity problem has the same significance for line planning in public transport as the Steiner tree problem for telecommunication network design. It consists in finding a minimum cost set of elementary paths to connect a subset of nodes in an undirected graph and is, therefore, a generalization of the Steiner tree problem. We propose an *extended directed cut formulation* for the problem which is, in comparison to the canonical undirected cut formulation, provably strong, implying, e.g., a class of facet defining Steiner partition inequalities. Since a direct application of this formulation is computationally intractable for large instances, we develop a *partial projection method* to produce a strong relaxation in the space of canonical variables that approximates the extended formulation. We also investigate the separation of Steiner partition inequalities and give computational evidence that these inequalities essentially close the gap between undirected and extended directed cut formulation. Using these techniques, large Steiner connectivity problems with up to 900 nodes can be solved within reasonable optimality gaps of typically less than five percent.

1 Introduction

The *Steiner connectivity problem* (SCP) can be described as follows. We are given an undirected graph $G = (V, E)$, a set of *terminal nodes* $T \subseteq V$, and a set of elementary *paths* \mathcal{P} in G . The paths have nonnegative costs $c \in \mathbb{R}_+^{\mathcal{P}}$. The problem is to find a set of paths $\mathcal{P}' \subseteq \mathcal{P}$ of minimal cost $\sum_{p \in \mathcal{P}'} c_p$ that *connect the terminals*, i.e., such that for each pair of distinct terminal nodes $t_1, t_2 \in T$ there exists a path q from t_1 to t_2 in G such that each edge of q is covered by at least one path of \mathcal{P}' . We can assume w.l.o.g. that every edge is covered by a path, i.e., for every $e \in E$ there is a $p \in \mathcal{P}$ such that $e \in p$; in particular, G has no loops. Figure 1 gives an example of a Steiner connectivity problem and a feasible solution.

The SCP is a generalization of the *Steiner tree problem* (STP), see, for example, [31, 33, 34], in which all paths contain exactly one edge. The STP is nowadays well investigated: A hierarchy of strong formulations is known and large scale instances can be solved, see [27] and the references therein. Steiner trees are fundamental for network design; see [2] for an overview. The STP can be seen as the prototype of all problems where nodes are connected by installing capacities on individual edges or arcs. Significant progress has been made in dealing with basic network design

[§]Supported by the DFG Research Center MATHEON “Mathematics for key technologies”

*Zuse Institute Berlin, Takustr. 7, 14195 Berlin, Germany; Email borndoerfer@zib.de, marika.neumann@zib.de

**TU Darmstadt, Department of Mathematics, Discrete Optimization, Dolivostr. 15, 64293 Darmstadt, Germany; Email pfetsch@mathematik.tu-darmstadt.de

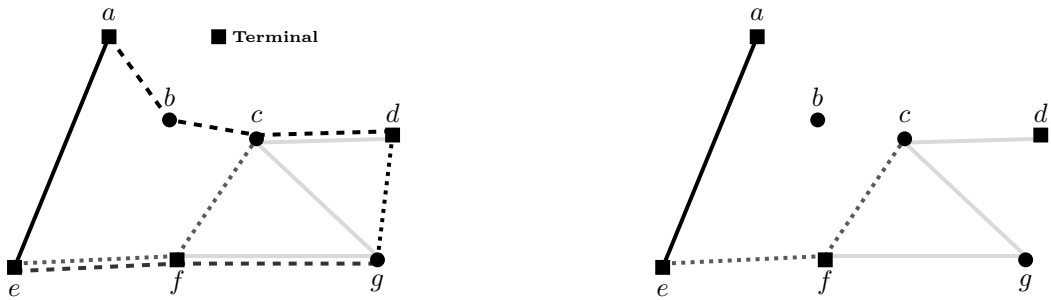

Figure 1: Example of a Steiner connectivity problem. *Left:* A graph with four terminal nodes ($T = \{a, d, e, f\}$) and six paths ($\mathcal{P} = \{p_1 = (a, b, c, d), p_2 = (e, f, g), p_3 = (a, e), p_4 = (e, f, c), p_5 = (g, d), p_6 = (f, g, c, d)\}$). *Right:* A feasible solution with three paths ($\mathcal{P}' = \{p_3, p_4, p_6\}$).

problems. In particular, large scale Steiner tree, uncapacitated and hierarchical network design problems can nowadays be solved effectively, see [34].

These advances carry over to more complex real world applications in telecommunications, supply chain, and utility networks, see again [2] for a survey; however, “more general situations continue to pose significant challenges to the optimization community” [2].

One such case is the line planning problem in public transport. Here, transportation capacities have to be installed on a set of paths (corresponding to bus, tram, and train lines), instead of individual arcs, such that all passengers can reach their destinations. These problems can be modeled as integer programs which integrate line and passenger routing [5, 29, 35, 36, 39]. They are computationally very difficult and despite of significant research efforts large scale problems with hundreds of nodes and thousands of lines have not been solved until very recently [6, 7]. A main challenge is the derivation of high quality lower bounds. The knowledge of the polyhedral structure is currently limited to only a few classes of valid and facet defining inequalities [17], see also [10, 11, 12, 14] for related work. To make progress in this direction, we provide a polyhedral analysis of the Steiner connectivity problem in this paper. Similar to the STP in network design, the SCP is a prototype for line planning: It captures the connectivity aspect. This problem has not been investigated yet.

Although the STP and the SCP look very similar at first glance, it is not possible to generalize structural results and algorithms from the Steiner tree problem directly to the Steiner connectivity problem. In fact, the SCP is NP-hard even for $T = V$ (see Proposition 2.4 below). Moreover, a formulation based on the corresponding directed graph as it is proposed by Chopra and Rao [13] for the STP does not exist for the SCP. Chopra and Rao showed that the LP relaxation of the undirected IP formulation of the STP, including all so-called Steiner partition inequalities, is dominated by a certain family of directed formulations; see also Polzin [31] and Polzin and Daneshmand [33]. For the SCP, analogous results can instead be derived from an extended formulation based on a suitably constructed directed Steiner tree problem. We show that this formulation is provably strong, including, e.g., a class of facet defining generalized Steiner partition inequalities, but often too large to be solved directly. However, it can be used to produce a strong relaxation of the Steiner connectivity problem via projection to the original space of variables.

Extended formulations have recently drawn considerable attention in the literature, see, e.g., Vanderbeck and Wolsey [40] and Conforti, Cornuéjols, and Zambelli [15] for surveys. They have high theoretical relevance for the analytic derivation of strong inequalities and tight descriptions, see Pochet and Wolsey [30] and the references therein for applications to production planning problems and Lovász and Schrijver [28] for applications to the stable set problem. Beyond these analyses and some direct applications, there are only a few examples of successful computational uses of extended formulations. These include the lift-and-project method, see Balas et. al. [3], and, recently, the work of Giandomenico et. al. [21] on the derivation of strong cutting planes for the stable set problem using the Lovász-Schrijver $M(K, K)$ operator. We investigate a similar approach, the partial projection method, to derive strong inequalities including facet defining cuts from a combinatorially motivated subsystem of an extended formulation. In our application, the extended directed cut formulation for the SCP is often too time consuming to be solved or even not solvable at all for large instances. However, the partial projection method can be used to produce a computationally tractable, strong approximation. We provide a computational comparison of this approach with a shrinking heuristic, which gives a very effective way to improve the canonical undirected cut formulation using Steiner partition inequalities. The comparison gives evidence that these inequalities close most of the gap between the canonical undirected and the extended directed cut formulation. The Steiner partition inequalities are therefore indeed very important for the solution of large scale Steiner connectivity problems with 1 000 and more nodes and several thousand paths.

The article is structured as follows. It starts with a combinatorial discussion of the Steiner connectivity problem in Section 2. We show that the SCP is equivalent to a suitably constructed but very large directed Steiner tree problem. This gives rise to an extended formulation and yields polynomial time algorithms for the SCP in some cases. In Section 3, we give two integer programming formulations for the SCP based on the transformation in Section 2, namely, an undirected cut formulation and an extended directed cut formulation. We compare these formulations and their LP relaxations. An analysis of the polytope associated with the undirected cut formulation follows in Section 4. We state necessary and sufficient conditions for the Steiner partition inequalities to be facet defining. We show that a super class of the Steiner partition inequalities can be separated in polynomial time. This shows that extended formulations provide tight relaxations for the SCP. We show in Section 5 that a shrinking-based separation of Steiner partition inequalities yields strong bounds for Steiner connectivity problems on large scale real-world transportation networks. In most cases, and with respect to a given time limit, these bounds are as strong as or even stronger than the bounds arising from the extended directed cut formulation or the bounds derived by a polynomial time algorithm to separate cuts from the extended formulation by projection.

2 Relation to Directed Steiner Trees & Complexity

We show in this section the equivalence of the SCP and a suitably constructed directed Steiner tree problem. The *directed Steiner tree problem* (DSTP) is the following: Given a directed graph and a set of terminal nodes T , we have to find a

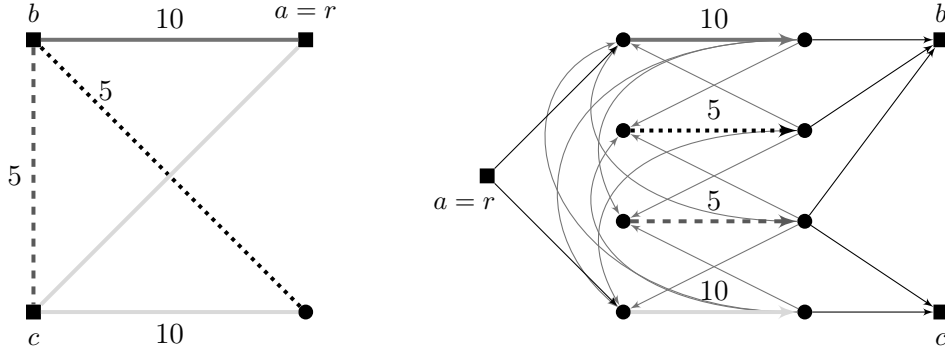

Figure 2: A Steiner connectivity problem and its associated directed Steiner tree problem. *Left:* Graph G with four paths and three terminal nodes. The numbers on the paths indicate costs. *Right:* Associated Steiner connectivity digraph D' . The numbers on the arcs are the costs; the default value is zero.

minimum cost set B of arcs that connect a *root node* $r \in T$ to each other terminal $t \in T \setminus \{r\}$, i.e., there exists a directed path from r to t in B . If the costs of the arcs are nonnegative, which we assume, there exists a solution that is a directed tree (an arborescence).

Consider an SCP with undirected graph $G = (V, E)$, a set of paths \mathcal{P} , terminals $T \subseteq V$, and nonnegative costs $c \in \mathbb{R}_+^{\mathcal{P}}$. Define nodes v_p, w_p for each path $p \in \mathcal{P}$ and a digraph $D' = (V', A')$, which we call *Steiner connectivity digraph*. Its node set is

$$V' := T \cup \{v_p, w_p : p \in \mathcal{P}\}.$$

We choose some terminal node $r \in T$ as root node and define the following arcs $a \in A'$ and costs c'_a :

$$\begin{aligned} a = (r, v_p), & \quad c'_a := 0, & \quad \forall p \in \mathcal{P} \text{ with } r \in p, \\ a = (v_p, w_p), & \quad c'_a := c_p, & \quad \forall p \in \mathcal{P}, \\ a = (w_{\tilde{p}}, v_p), & \quad c'_a := 0, & \quad \forall p, \tilde{p} \in \mathcal{P}, p \neq \tilde{p}, p \text{ and } \tilde{p} \text{ have} \\ & & \quad \text{a node } v \in V \text{ in common,} \\ a = (w_p, t), & \quad c'_a := 0, & \quad \forall p \in \mathcal{P}, \forall t \in T \setminus \{r\} \text{ with } t \in p. \end{aligned}$$

Figure 2 illustrates our construction. Note that choosing different root nodes results in different Steiner connectivity digraphs and hence different associated DSTPs. However, we will show in Proposition 2.2 that the solutions of an SCP and any associated DSTP are all equivalent, independent of the choice of the root node. For ease of notation, we will therefore omit the root node whenever the results are independent of r . Polyhedral results can depend on the choice of the root node, see Remark 3.9 below. In such cases we will include the root node in the notation.

A DSTP associated with an SCP has the following properties.

- Observation 2.1.** 1. The only arc with target node w_p is (v_p, w_p) , for all $p \in \mathcal{P}$.
2. The only arc with source node v_p is (v_p, w_p) , for all $p \in \mathcal{P}$.
3. Each elementary directed (r, t) -path, $t \in T \setminus \{r\}$, has the general form $(r, v_{p_1}, w_{p_1}, \dots, v_{p_k}, w_{p_k}, t)$, $k \geq 1$.

Proposition 2.2. *The following holds for an SCP and an associated DSTP: For each solution of one problem there exists a solution of the other problem with the same objective value. In particular, the optimal objective value of an associated DSTP is independent of the choice of the root node.*

Proof. Assume $\tilde{\mathcal{P}}$ is a solution of SCP. Then let

$$\tilde{A} := A' \setminus \{(v_p, w_p) : p \notin \tilde{\mathcal{P}}\}.$$

The arcs in \tilde{A} connect the root r with each terminal $t \in T \setminus \{r\}$ via a directed path. Moreover, $\sum_{a \in \tilde{A}} c'_a = \sum_{p \in \tilde{\mathcal{P}}} c'_{v_p w_p} = \sum_{p \in \tilde{\mathcal{P}}} c_p$.

For the converse, assume that \tilde{A} is a solution of the DSTP. We show that

$$\tilde{\mathcal{P}} := \{p \in \mathcal{P} : (v_p, w_p) \in \tilde{A}\}$$

is a solution of the corresponding SCP with the same cost. To this purpose, consider the root node r and some terminal $t \in T \setminus \{r\}$; these nodes are connected by an elementary directed path in D' using only arcs in \tilde{A} . Each such path has the form $(r, v_{p_1}, w_{p_1}, \dots, v_{p_k}, w_{p_k}, t)$, $k \geq 1$ (see Observation 2.1), with $(v_{p_i}, w_{p_i}) \in \tilde{A}$, $i = 1, \dots, k$, that is, $p_i \in \mathcal{P}$, $i = 1, \dots, k$. Due to the construction of D' , p_1 contains r , p_i and p_{i+1} , $i = 1, \dots, k-1$, have at least one node in common, and p_k contains t . Hence, we can find a path from r to t in G that is covered by $p_1, \dots, p_k \in \tilde{\mathcal{P}}$. Since the paths are undirected, every two terminals $t_1, t_2 \in T$, $t_1, t_2 \neq r$, can be connected via r , i.e., $\tilde{\mathcal{P}}$ connects T . Furthermore, $\sum_{p \in \tilde{\mathcal{P}}} c_p = \sum_{p \in \tilde{\mathcal{P}}} c'_{v_p w_p} = \sum_{a \in \tilde{A}} c'_a$.

These arguments hold for every root node. \square

Since the Steiner connectivity problem is a generalization of the Steiner tree problem, it is strongly NP-hard in general. The relation to the associated DSTP, however, exhibits a number of polynomially solvable cases.

Corollary 2.3. *SCP is solvable in polynomial time for $|T| = k$, k constant.*

Proof. This follows from the complexity results for the directed Steiner tree problem, see Feldman and Ruhl [20]. \square

Note that the SCP for $|T| = 2$ can be solved by a directed shortest path computation in the Steiner connectivity digraph.

In contrast to the STP, however, we can show the following.

Proposition 2.4. *SCP is strongly NP-hard for $T = V$, even for unit costs.*

Proof. We reduce the set covering problem to the Steiner connectivity problem. In a set covering problem we are given a finite set S and a set $\mathcal{M} \subseteq 2^S$. The problem is to find a subset $\mathcal{M}' \subseteq \mathcal{M}$ of minimal cardinality $|\mathcal{M}'|$, such that for all $s \in S$ there exists an $M \in \mathcal{M}'$ with $s \in M$.

Given a set covering instance, we define a Steiner connectivity instance in a graph $G = (V, E)$ as follows: The nodes are $V = S \cup \{v\} = T$ with v being one extra node. Let us write $V = \{s_0, s_1, s_2, \dots\}$, where $v = s_0$. All nodes are terminals. We first assume that G is a complete graph and later remove all edges that are not covered by paths after their construction. For each set $M \in \mathcal{M}$ order the elements in M

arbitrarily and construct a path beginning in node v and passing through all nodes of M in the given order. The cost of each such path is 1.

It is easy to see that a cover \mathcal{M}' with at most k elements exists if and only if a set of paths exists that connects all nodes with cost at most k , $k \geq 0$. \square

Corollary 2.5. *SCP is strongly NP-hard for $|T| = |V| - k$, k constant.*

Proof. We add k isolated nodes to the graph G in the proof of Proposition 2.4. \square

Proposition 2.6. *Unless $P = NP$, there exists no polynomial time α -approximation algorithm for SCP with $\alpha = \gamma \cdot \log |V|$, $\gamma \leq 1$.*

Proof. The transformation in Proposition 2.4 is approximation preserving, since there exists a cost preserving bijection between the solutions of a set covering instance and its corresponding Steiner connectivity instance. It has been shown that the set covering problem is not approximable in the sense that there exists no polynomial time approximation algorithm with approximation factor smaller than logarithmic (in the number of nodes) unless $P = NP$, see Feige [19]. \square

3 Integer Programming Formulations

We propose in this section two integer programming formulations for the SCP. The first one (SCP_{cut}) is the canonical undirected cut formulation, the second one (SCP_{arc+}^r) is a directed cut formulation based on the equivalence between the SCP and its associated DSTP. It will turn out that (SCP_{arc+}^r) dominates (SCP_{cut}).

We use the following notation. For a vector $x \in \mathbb{R}^n$ and an index set $I \subseteq \{1, \dots, n\}$, let $x|_I = x_I$ be the restriction of x onto the subspace indexed by I . Let $P_{LP}(F)$ be the polyhedron associated with the LP relaxation of an IP formulation F . Then $P_{LP}(F)|_I$ is the orthogonal projection of $P_{LP}(F)$ on the subspace of variables indexed by I .

3.1 Cut Formulation

The *cut formulation* is as follows:

$$\begin{aligned}
 (\text{SCP}_{cut}) \quad & \min && \sum_{p \in \mathcal{P}} c_p x_p \\
 \text{(i)} \quad & \text{s.t.} && \sum_{p \in \mathcal{P}_{\delta(W)}} x_p \geq 1 && \forall W \subseteq V, \emptyset \neq W \cap T \neq T \\
 & && x_p \in \{0, 1\} && \forall p \in \mathcal{P}.
 \end{aligned}$$

Here, x_p is a 0/1-variable that indicates whether path p is chosen ($x_p = 1$) or not ($x_p = 0$). Furthermore, $\mathcal{P}_{\delta(W)} := \{p \in \mathcal{P} : \delta(W) \cap p \neq \emptyset\}$ is the set of all paths that cross the cut $\delta(W) = \{\{u, v\} \in E : |\{u, v\} \cap W| = 1\}$ at least one time. If $\delta(W)$ is an (s, t) -cut for some terminal nodes $s, t \in T$, i.e., if $s \notin W, t \in W$, we call $\mathcal{P}_{\delta(W)}$ an (s, t) -Steiner path cut or shortly a Steiner path cut; a Steiner path cut $\mathcal{P}_{\delta(W)}$ with $|\mathcal{P}_{\delta(W)}| = 1$ is a Steiner path bridge. For a given x , the capacity of a Steiner path cut $\mathcal{P}_{\delta(W)}$ is $\sum_{p \in \mathcal{P}_{\delta(W)}} x_p$, and we denote the inequalities $(\text{SCP}_{cut})(i)$ as Steiner path cut

constraints; they state that the capacity of each Steiner path cut must be at least one. It is easy to see that (SCP_{cut}^w) is a valid formulation for the SCP.

If each path has length 1, i.e., contains only one edge, the sets $\delta(W)$ and $\mathcal{P}_{\delta(W)}$ are equal. In this case the Steiner connectivity problem reduces to a Steiner tree problem, and the Steiner path cut constraints reduce to the so-called *Steiner cut constraints*.

Replacing the Steiner path cut constraints by a weaker version produces a second integer program

$$\begin{aligned}
(\text{SCP}_{cut}^w) \quad & \min && \sum_{p \in \mathcal{P}} c_p x_p \\
\text{(i)} \quad & \text{s.t.} && \sum_{e \in \delta(W)} \sum_{p: e \in p} x_p \geq 1 && \forall W \subseteq V, \emptyset \neq W \cap T \neq T \\
&&&&&& x_p \in \{0, 1\} && \forall p \in \mathcal{P}.
\end{aligned}$$

This *weak cut formulation* is also a correct IP formulation of the SCP. Note that the left hand side of a *weak Steiner path cut constraint* (SCP_{cut}^w) (i) counts how often each path crosses the cut $\delta(W)$. These inequalities can be seen as a direct generalization of the Steiner cut constraints for the STP. However, they are clearly dominated by the Steiner path cut constraints.

Some Steiner path cut constraints are themselves dominated by others. In fact, the non-dominated ones correspond to minimal disconnecting sets. A set $\mathcal{P}' \subseteq \mathcal{P}$ is a *disconnecting set* if there exist two terminal nodes which are not connected via $\mathcal{P} \setminus \mathcal{P}'$.

Lemma 3.1. *Minimal disconnecting sets are minimal Steiner path cuts (w.r.t. inclusion) and vice versa.*

Proof. “ \Rightarrow ”: Let $\mathcal{P}' \subseteq \mathcal{P}$ be a minimal disconnecting set, and let $s, t \in T$ be two terminal nodes that are disconnected. Define W to be the nodes reachable from t via $\mathcal{P} \setminus \mathcal{P}'$. Note that $s \notin W$ and $t \in W$, and hence $\mathcal{P}_{\delta(W)}$ is an (s, t) -Steiner path cut. We claim that $\mathcal{P}_{\delta(W)} = \mathcal{P}'$.

- Assume $p \in \mathcal{P}_{\delta(W)} \setminus \mathcal{P}'$. Hence, p connects some node u in $V \setminus W$ to some node $v \in W$. By definition of W , $\mathcal{P} \setminus \mathcal{P}'$ connects v and t , and since $p \in \mathcal{P} \setminus \mathcal{P}'$ connects u and v , $\mathcal{P} \setminus \mathcal{P}'$ connects u and t . It follows that $u \in W$, a contradiction. Hence, $\mathcal{P}_{\delta(W)} \subseteq \mathcal{P}'$.
- Conversely, assume $p \in \mathcal{P}' \setminus \mathcal{P}_{\delta(W)}$. Since $\mathcal{P}_{\delta(W)} \subseteq \mathcal{P}'$ is a disconnecting set for s and t , it follows that \mathcal{P}' is not minimal, another contradiction.

Finally, $\mathcal{P}_{\delta(W)}$ is minimal w.r.t. inclusion, because otherwise $\mathcal{P}' = \mathcal{P}_{\delta(W)}$ would not be minimally disconnecting.

“ \Leftarrow ”: Let $W \subseteq V$ with $\emptyset \neq W \cap T \neq T$, such that $\mathcal{P}_{\delta(W)}$ is minimal w.r.t. inclusion. Then $\mathcal{P}_{\delta(W)}$ is a disconnecting set, because no terminal in W is connected to a terminal in $V \setminus W$ via $\mathcal{P} \setminus \mathcal{P}_{\delta(W)}$. We claim that $\mathcal{P}_{\delta(W)}$ is also a minimal disconnecting set. Suppose not; then there is some smaller disconnecting set $\mathcal{P}' \subsetneq \mathcal{P}_{\delta(W)}$, which we can assume to be minimal. By the forward direction of the proof, $\mathcal{P}' = \mathcal{P}_{\delta(W')}$ for some set $W' \subseteq V$, $\emptyset \neq W' \cap T \neq T$. It follows that $\mathcal{P}_{\delta(W')} = \mathcal{P}' \subsetneq \mathcal{P}_{\delta(W)}$, i.e., $\mathcal{P}_{\delta(W)}$ was not minimal w.r.t. inclusion, a contradiction. \square

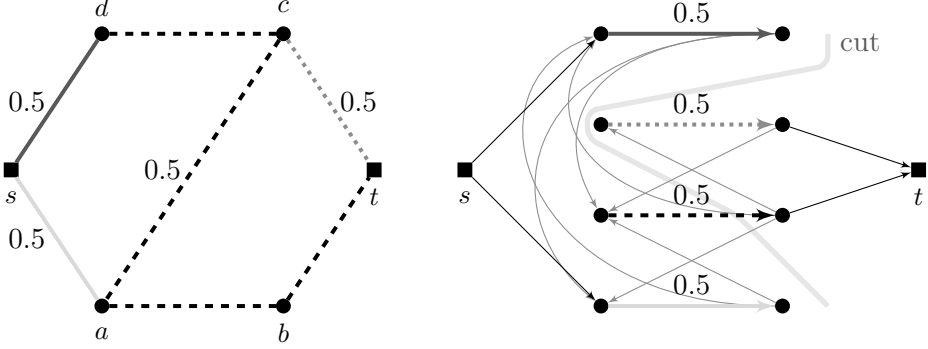

Figure 3: *Left:* Graph G with four paths ($p_1 = (s, d)$, $p_2 = (c, t)$, $p_3 = (d, c, a, b, t)$, $p_4 = (s, a)$) with value 0.5 and two terminal nodes s and t . *Right:* Corresponding directed graph D' . Here, each arc has capacity 0.5. The minimum directed (s, t) -cut has value 0.5 and corresponds to the Steiner path cut $\mathcal{P}' = \{p_3\}$ in G .

Formulation $(\text{SCP}_{\text{cut}})$ has $|\mathcal{P}|$ variables and $O(2^{|\mathcal{P}|})$ constraints, i.e., the number of Steiner path cut constraints can be exponential in the size of the input. However, the associated separation problem, i.e., to decide whether a given point \hat{x} is feasible for the LP relaxation of $(\text{SCP}_{\text{cut}})$ or to find a violated Steiner path cut constraint, can be solved in polynomial time. Namely, this problem can be formulated as a family of max flow/min cut problems in the Steiner connectivity digraph $D' = (V', A')$ that was defined in Section 2. Consider some nonnegative vector $\hat{x} \in \mathbb{R}_+^{\mathcal{P}}$. We define the following *standard arc capacities* $\kappa = \kappa(\hat{x})$ for D' :

$$\begin{aligned}
a = (r, v_p), \quad \kappa_a &:= \hat{x}_p, & \forall p \in \mathcal{P} \text{ with } r \in p, \\
a = (v_p, w_p), \quad \kappa_a &:= \hat{x}_p, & \forall p \in \mathcal{P}, \\
a = (w_{\tilde{p}}, v_p), \quad \kappa_a &:= \min\{\hat{x}_p, \hat{x}_{\tilde{p}}\}, & \forall p, \tilde{p} \in \mathcal{P}, p \neq \tilde{p}, p \text{ and } \tilde{p} \text{ have} \\
& & \text{a node } v \in V \text{ in common,} \\
a = (w_p, t), \quad \kappa_a &:= \hat{x}_p, & \forall p \in \mathcal{P}, \forall t \in T \setminus \{r\} \text{ with } t \in p.
\end{aligned}$$

Figure 3 illustrates this construction. The following holds.

Lemma 3.2. *Let $t \in T \setminus \{r\}$ be a terminal node and $\hat{x} \in \mathbb{R}_+^{\mathcal{P}}$ be a non-negative vector. If the Steiner connectivity digraph D' has standard capacities $\kappa = \kappa(\hat{x})$, there exists a directed (r, t) -cut with minimum capacity in D' such that all arcs over this cut are of the form (v_p, w_p) , $p \in \mathcal{P}$.*

Proof. Let $\delta^-(W)$ be a directed (r, t) -cut with $W \subseteq V \setminus \{r\}$. We show that we can derive an alternative cut set \tilde{W} with smaller or equal capacity where all arcs are of the form (v_p, w_p) . Thus, if $\delta^-(W)$ has minimum capacity, then $\delta^-(\tilde{W})$ has minimum capacity as well.

- Assume $(r, v_p) \in \delta^-(W)$, i.e., $v_p \in W$. We set $\tilde{W} = W \setminus \{v_p\} \cup \{w_p\}$ and get $\delta^-(\tilde{W}) \subseteq \delta^-(W) \setminus \{(r, v_p)\} \cup \{(v_p, w_p)\}$, because (v_p, w_p) is the only arc with source node v_p and target node w_p , recall statements 1 and 2 of Observation 2.1. Furthermore, $(v_p, w_p) \in \delta^-(\tilde{W})$ and $\kappa_{rv_p} = \kappa_{v_p w_p}$. Hence, $\delta^-(\tilde{W})$ has capacity not larger than $\delta^-(W)$.
- If $(w_p, t) \in \delta^-(W)$, we set $\tilde{W} = W \setminus \{v_p\} \cup \{w_p\}$ and argue as above.
- Assume $(w_{\tilde{p}}, v_p) \in \delta^-(W)$, $p \neq \tilde{p}$, and $\hat{x}_p \leq \hat{x}_{\tilde{p}}$. In this case, we set $\tilde{W} = W \setminus \{v_p\} \cup \{w_p\}$ and get $\delta^-(\tilde{W}) \subseteq \delta^-(W) \setminus \{(w_{\tilde{p}}, v_p)\} \cup \{(v_p, w_p)\}$, again because

of statements 1 and 2 of Observation 2.1. Furthermore, $(v_p, w_p) \in \delta^-(\tilde{W})$ and $\kappa_{v_p w_p} = \kappa_{w_{\tilde{p}} v_p}$. Hence, $\delta^-(\tilde{W})$ has capacity not larger than $\delta^-(W)$.

- Assume $(w_{\tilde{p}}, v_p) \in \delta^-(W)$, $p \neq \tilde{p}$, and $\hat{x}_{\tilde{p}} \leq \hat{x}_p$. In this case we set $\tilde{W} = W \setminus \{v_{\tilde{p}}\} \cup \{w_{\tilde{p}}\}$ and argue similarly.

In all cases, the set W changes in such a way that nodes w_p enter W and nodes v_p leave W . Hence all steps can be repeated until the cut has the desired form. \square

We call a cut of the form stated in Lemma 3.2 a *standard cut*; then Lemma 3.2 can be rephrased as stating that there exists a minimum capacity directed (r, t) -cut in a Steiner connectivity digraph with standard capacities which is a standard cut.

Proposition 3.3. *Let $\kappa \in \mathbb{R}_+^{A'}$ and $\hat{x} \in \mathbb{R}_+^{\mathcal{P}}$ be capacities for D' and G , respectively, such that $\kappa_a = \hat{x}_p$ for all $a = (v_p, w_p) \in A'$, $p \in \mathcal{P}$. Then there is a one-to-one correspondence between minimal directed (r, t) -standard cuts in D' (w.r.t. root node r) and minimal (r, t) -Steiner path cuts in G , and the capacities are equal.*

Proof. “ \Rightarrow ”: Consider a directed (r, t) -standard cut $\delta^-(W')$ in D' . We first show that $\delta^-(W')$ gives rise to an (r, t) -disconnecting set

$$\mathcal{P}' = \{p \in \mathcal{P} : (v_p, w_p) \in \delta^-(W')\}$$

in G . Assume there exists a path from r to t in G that is covered only by paths in $\mathcal{P} \setminus \mathcal{P}'$ (i.e., \mathcal{P}' is not a disconnecting set). Let p_1, \dots, p_k be the paths that are used in this order when traversing the path. Then $(r, v_{p_1}, w_{p_1}, \dots, v_{p_k}, w_{p_k}, t)$ is a path from r to t in D' that uses only arcs in $A' \setminus \delta^-(W')$. This is a contradiction to the assumption that $\delta^-(W')$ is a directed (r, t) -standard cut in D' .

Now let $\delta^-(W')$ be minimal and suppose \mathcal{P}' is not. Then there exists a smaller (r, t) -disconnecting set $\mathcal{P}'' \subset \mathcal{P}'$. Consider for some path $p \in \mathcal{P}' \setminus \mathcal{P}''$ the arc $(v_p, w_p) \in \delta^-(W')$. As $\delta^-(W')$ is a minimal disconnecting set in D' , there is an (r, t) -path $(r, v_{p_1}, w_{p_1}, \dots, v_{p_k}, w_{p_k}, t)$ in $A' \setminus \delta^-(W') \cup \{v_p, w_p\}$. But then p_1, \dots, p_k is a set of paths in $\mathcal{P} \setminus \mathcal{P}' \cup \{p\} \subseteq \mathcal{P} \setminus \mathcal{P}''$ that connect r and t in G , i.e., \mathcal{P}'' is not an (r, t) -disconnecting set. This is a contradiction. Therefore \mathcal{P}' is minimally disconnecting and, by Lemma 3.1, \mathcal{P}' is a minimal (r, t) -Steiner path cut.

“ \Leftarrow ”: Let \mathcal{P}' be an (r, t) -Steiner path cut. Then \mathcal{P}' is an (r, t) -disconnecting set in G . Define

$$W' = \{t\} \cup \{w_p : p \in \mathcal{P}'\} \cup W'',$$

where W'' is the set of nodes from which t can be reached using arcs in the set $A' \setminus \{(v_p, w_p) | p \in \mathcal{P}'\}$. Then we show that $\delta^-(W')$ is a directed (r, t) -standard cut in D' , namely,

$$\delta^-(W') = \{(v_p, w_p) : p \in \mathcal{P}'\}.$$

It is clear that $\delta^-(W') \supseteq \{(v_p, w_p) : p \in \mathcal{P}'\}$, because the only node that can be reached from v_p is w_p . To show equality, consider the following cases:

- Assume $(r, v_p) \in \delta^-(W')$ for some $p \in \mathcal{P}$. If $p \in \mathcal{P}'$, then $v_p \notin W'$, a contradiction. If $p \notin \mathcal{P}'$ then t can be reached from v_p via arcs in $A' \setminus \{(v_p, w_p) | p \in \mathcal{P}'\}$. Hence, there is an (r, t) -path covered by $p \in \mathcal{P} \setminus \mathcal{P}'$, a contradiction.
- Assume $(w_p, t) \in \delta^-(W')$ for some $p \in \mathcal{P}$. For both cases $p \in \mathcal{P}'$ and $p \notin \mathcal{P}'$ we have $w_p \in W'$, a contradiction.

- Assume $(v_p, w_p) \in \delta^-(W')$ for some $p \in \mathcal{P} \setminus \mathcal{P}'$. Then $w_p \in W'$, i.e., t can be reached from w_p via arcs in $A' \setminus \{(v_p, w_p) | p \in \mathcal{P}'\}$, but $v_p \notin W'$, a contradiction.
- Assume $(w_{\tilde{p}}, v_p) \in \delta^-(W')$ for some $p, \tilde{p} \in \mathcal{P}$. Then $w_{\tilde{p}} \notin W'$ and $v_p \in W'$. This implies that t can be reached from v_p via arcs in $A' \setminus \{(v_p, w_p) | p \in \mathcal{P}'\}$. But then t can also be reached from $w_{\tilde{p}}$ via arcs in $A' \setminus \{(v_p, w_p) | p \in \mathcal{P}'\}$, a contradiction.

Now assume that \mathcal{P}' is a minimal (r, t) -Steiner path cut (i.e., a minimal (r, t) -disconnecting set via Lemma 3.1) and $\delta^-(W')$ is not, i.e., there exists a standard cut $\delta^-(W'') \subset \delta^-(W') = \{(v_p, w_p) : p \in \mathcal{P}'\}$. Then by the forward argument of the proof there exists a disconnecting set $\mathcal{P}'' \subsetneq \mathcal{P}'$, a contradiction.

“ \Leftrightarrow ”: It is easy to see that in both cases \mathcal{P}' and $\delta^-(W')$ have the same capacity, and that the constructions in the two directions of the proof pair the same cuts. \square

Remark 3.4. Note that Proposition 3.3 holds for *all* capacities such that $\kappa_a = \hat{x}_p$ for all $a = (v_p, w_p) \in A'$, $p \in \mathcal{P}$, not only for standard capacities.

Theorem 3.5. *The separation problem for Steiner path cut constraints can be solved in polynomial time.*

Proof. Computing for every two terminals $s, t \in T$ a minimum (s, t) -cut in D' with respect to standard capacities, using s as root node, can be done in polynomial time. If and only if the value of this cut is smaller than 1, we can find a violated Steiner path cut constraint by transforming this cut into a standard cut via Lemma 3.2 and then apply Proposition 3.3. This can also be done in polynomial time. \square

3.2 Directed Cut Formulation

Our second formulation of the SCP is the well-known *directed cut formulation* for the associated DSTP in D' [13]:

$$\begin{aligned}
 (\text{SCP}_{arc}) \quad & \min && \sum_{a \in A'} c'_a y_a \\
 \text{(i)} \quad & \text{s.t.} && \sum_{a \in \delta^-(W')} y_a \geq 1 && \forall W' \subseteq V' \setminus \{r\}, W' \cap T \neq \emptyset \\
 & && y_a \in \{0, 1\} && \forall a \in A'.
 \end{aligned}$$

Compared to the undirected cut formulation, the number of variables of (SCP_{arc}) is quadratic, i.e., $|A'| \in O(|\mathcal{P}|^2)$, and the number of constraints is quadratically exponential, i.e., $O(2^{(|\mathcal{P}|^2)})$. The separation problem for the *directed Steiner cut constraints* (SCP_{arc}) (i) consists of solving $|T| - 1$ min-cut problems, i.e., for each $t \in T \setminus \{r\}$ one has to find a minimum (r, t) -cut in D' . This can be done in polynomial time.

(SCP_{arc}) can be interpreted as an extended formulation of (SCP_{cut}) by identifying arcs (v_p, w_p) and paths $p \in \mathcal{P}$. We define

$$A'_p = \{(v_p, w_p) \in A' : p \in \mathcal{P}\}$$

and write $y|_{\mathcal{P}} = y|_{A'_p}$ to simplify the notation. Then, Proposition 2.2 states that if y is an integer solution of (SCP_{arc}) , its projection on the subspace of *path-arcs* gives rise to a solution $x = y|_{\mathcal{P}}$ of (SCP_{cut}) via $x_p = y_{v_p w_p}$, $p \in \mathcal{P}$, and vice versa. This relation also holds for the LP relaxations of (SCP_{cut}) and (SCP_{arc}) .

Lemma 3.6. $P_{LP}(\text{SCP}_{cut}) = P_{LP}(\text{SCP}_{arc})|_{\mathcal{P}}$.

Proof. “ \supseteq ”: Let $\hat{y} \in P_{LP}(\text{SCP}_{arc})$, i.e., \hat{y} satisfies all directed (r, t) -Steiner cuts for some root r and every terminal $t \in T \setminus \{r\}$. By Proposition 3.3 and Remark 3.4, the vector $\hat{x} = \hat{y}|_{\mathcal{P}}$ satisfies all (r, t) -Steiner path cuts for every terminal $t \in T \setminus \{r\}$. Since any (s, t) -Steiner path cut is either an (r, s) - or an (r, t) -Steiner path cut, $\hat{y}|_{\mathcal{P}}$ also satisfies the (s, t) -Steiner path cuts for all $s, t \in T \setminus \{r\}$, i.e., $\hat{y}|_{\mathcal{P}} = \hat{x} \in P_{LP}(\text{SCP}_{cut})$.

“ \subseteq ”: Let $\hat{x} \in P_{LP}(\text{SCP}_{cut})$, in particular, \hat{x} satisfies the (s, t) -Steiner path cuts for all $s, t \in T$ and hence all (r, t) -Steiner path cuts for some fixed root r . We define $\hat{y} \in \mathbb{R}^{A'}$ by setting $\hat{y} = \kappa(\hat{x})$ according to the standard capacity definition, i.e., in particular, $\hat{y}|_{\mathcal{P}} = \hat{x}$. By Proposition 3.3, the vector \hat{y} satisfies all directed (r, t) -standard cuts, and by Lemma 3.2, all directed (r, t) -cuts, i.e., $\hat{y} \in P_{LP}(\text{SCP}_{arc})$. \square

Corollary 3.7. *The optimal objective values of the LP relaxations of (SCP_{arc}) and (SCP_{cut}) are equal. In particular, the objective value of the LP relaxation of (SCP_{arc}) is independent of the choice of the root node r .*

Proof. This follows from Lemma 3.6, since $c'|_{\mathcal{P}} = c$ and $c'|_{A' \setminus A_{\mathcal{P}}} = 0$. \square

Lemma 3.6 and Corollary 3.7 show a difference between the Steiner connectivity and the Steiner tree problem: In contrast to the STP, where the directed formulation dominates the undirected formulation immediately, the undirected and the directed cut formulation for the SCP are equivalent in terms of quality and tractability. However, it is known that directed cut formulations for the STP can easily be strengthened by a small number of inequalities that one can write down explicitly. It will turn out that in our case such a strengthening dominates a large class of facet defining Steiner partition inequalities for the undirected formulation of the SCP, as we will see in Section 4.

The added inequalities are as follows. Since we assume nonnegative costs, there is always an optimal solution of the associated DSTP that is a directed tree. Each non-terminal node that is contained in such a cost minimal directed Steiner tree has at least one outgoing arc and at most one incoming arc. Therefore, the so-called *flow balance inequalities* can be added to (SCP_{arc}) :

$$\sum_{a \in \delta^-(v)} y_a \leq \sum_{a \in \delta^+(v)} y_a \quad \forall v \in V' \setminus T.$$

In the context of the Steiner tree problem these inequalities were first considered by Duin [18] and later studied by Koch and Martin [27] and Polzin [31, 32]. Because of the special form of the Steiner connectivity digraph and the objective function, it suffices to consider the flow balance constraints only for the nodes v_p , $p \in \mathcal{P}$. The lower right of Figure 4 shows an example of a typical violation of these constraints: Setting the y -variables associated with the thick arcs to 0.5 produces a solution that satisfies all directed Steiner cut constraints, but violates the flow balance constraint at node 2. Appending the flow balance constraints produces the following *strengthened*

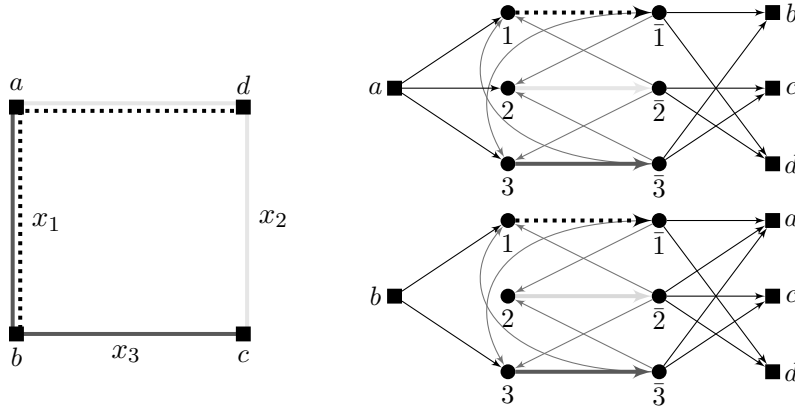

Figure 4: An SCP instance showing that choosing different roots leads to different solutions of the LP relaxation of (SCP_{arc+}^r) . Choosing node a as root allows to set all path values to 0.5 in the LP relaxation of (SCP_{arc+}^a) . This solution is not possible for the LP relaxation of (SCP_{arc+}^b) , when b is chosen as root.

directed cut formulation for the SCP:

$$\begin{aligned}
(\text{SCP}_{arc+}^r) \quad & \min \quad \sum_{a \in A'} c'_a y_a \\
\text{s.t.} \quad & \sum_{a \in \delta^-(W')} y_a \geq 1 \quad \forall W' \subseteq V' \setminus \{r\}, W' \cap T \neq \emptyset \\
& y_{v_p w_p} \geq \sum_{a \in \delta^-(v_p)} y_a \quad \forall (v_p, w_p) \in A' (p \in \mathcal{P}) \\
& y_a \in \{0, 1\} \quad \forall a \in A'.
\end{aligned}$$

The optimal objective values of (SCP_{arc+}^r) and (SCP_{arc}) are equal, but the LP relaxation of the first might be stronger.

Corollary 3.8. $P_{LP}(\text{SCP}_{cut}) = P_{LP}(\text{SCP}_{arc})|_{\mathcal{P}} \supseteq P_{LP}(\text{SCP}_{arc+}^r)|_{\mathcal{P}}$.

Remark 3.9. The objective value of the LP relaxation of (SCP_{arc+}^r) is not independent of the choice of the root node, see Figure 4.

Remark 3.10. The size of the Steiner connectivity digraph can be slightly reduced by contracting the path-arcs (v_p, w_p) , modifying the directed cut inequalities and the flow balance constraints appropriately. One can show that the *contracted directed cut formulation* arising in this way is equivalent to (SCP_{arc+}^r) . However, the number of variables is still quadratic in \mathcal{P} , and it is easier to relate (SCP_{arc+}^r) to (SCP_{cut}) . For this reason, we will not investigate this model further.

4 Polyhedral Analysis

In this section, we investigate the polytope that is associated with the cut formulation of the Steiner connectivity problem. We analyze a class of facet defining Steiner partition inequalities, and discuss the corresponding separation problem. Let

$$P_{\text{SCP}} := \text{conv} \{ \mathbf{x} \in \{0, 1\}^{\mathcal{P}} : \mathbf{x} \text{ satisfies all Steiner path cut constraints} \}$$

be the *Steiner connectivity polytope*. We assume that the Steiner connectivity polytope is non-empty, i.e., the graph G is connected, and each edge is covered by at least one path of \mathcal{P} . In the two-terminal case, a complete description can be given.

Proposition 4.1. *The polytope associated with (SCP_{cut}) is integral for $|T| = 2$.*

Proof. This follows from Lemma 3.6 and the fact that the polytope associated with (SCP_{arc}) is integral for two terminal nodes (see, e.g., Cornuéjols [16]). \square

Formulation (SCP_{cut}) is a special set covering problem. Therefore, the results of Balas and Ng [4] imply the following two lemmas.

Lemma 4.2. *P_{SCP} is full dimensional if and only if there exists no Steiner path bridge.*

Lemma 4.3. *The polytope associated with a Steiner connectivity problem without Steiner path bridges has the following properties:*

1. *The inequality $x_p \geq 0$ defines a facet of P_{SCP} if and only if $|\mathcal{P}_{\delta(W)}| \geq 3$ for all W with $p \in \mathcal{P}_{\delta(W)}$ and $\emptyset \neq W \cap T \neq T$.*
2. *All inequalities $x_p \leq 1$ define facets of P_{SCP} .*
3. *All facet defining inequalities $\alpha^T x \geq \alpha_0$ for P_{SCP} have $\alpha \geq 0$ if $\alpha_0 > 0$.*
4. *A Steiner path cut inequality for $\emptyset \neq W \cap T \neq T$ is facet defining if and only if the following two properties are satisfied:*

- (a) *There exists no W' , $\emptyset \neq W' \cap T \neq T$, such that $\mathcal{P}_{\delta(W')} \subsetneq \mathcal{P}_{\delta(W)}$, i.e., $\mathcal{P}_{\delta(W)}$ is not dominated.*
- (b) *For every two W_1, W_2 , $\emptyset \neq W_i \cap T \neq T$, with $|\mathcal{P}_{\delta(W_i)} \setminus \mathcal{P}_{\delta(W)}| = 1$, $i = 1, 2$ and $\mathcal{P}_{\delta(W_1)} \setminus \mathcal{P}_{\delta(W)} = \mathcal{P}_{\delta(W_2)} \setminus \mathcal{P}_{\delta(W)}$, we have*

$$|\mathcal{P}_{\delta(W_1)} \cap \mathcal{P}_{\delta(W_2)} \cap \mathcal{P}_{\delta(W)}| \geq 1.$$

5. *The only nontrivial facet defining inequalities for P_{SCP} with integer coefficients and right hand side equal to 1 are Steiner path cut constraints.*

In the sequel, we assume P_{SCP} to be full dimensional.

4.1 Steiner Partition Inequalities

Lemma 4.3 characterizes completely which inequalities of the IP formulation (SCP_{cut}) define facets of the Steiner connectivity polytope. We investigate in this section inequalities arising from node partitions as one important example of an additional class of facets.

Let $\mathcal{P} = (V_1, \dots, V_k)$ be a *Steiner partition* of the node set V , i.e., \mathcal{P} partitions V and $V_i \cap T \neq \emptyset$ for $i = 1, \dots, k$ and $k \geq 2$. Let $G_{\mathcal{P}} = (V_{\mathcal{P}}, E_{\mathcal{P}})$ be the graph that arises from contracting each node set $V_i \subseteq V$ to a single node $V_i \in V_{\mathcal{P}}$ (let us denote by V_i a node set in a partition of G as well as a node in the shrunk graph $G_{\mathcal{P}}$). Note that $G_{\mathcal{P}}$ can have parallel edges but no loops; loops are contracted. Consider a path $p \in \mathcal{P}$: p gives rise to a contracted (not necessarily elementary) path in $G_{\mathcal{P}}$, which we also denote by p . We say that p *contains* V_i , in formulas $V_i \in p$, if p contains a node of V_i (even if a path $p \in \mathcal{P}$ contains only a single node of $G_{\mathcal{P}}$). Furthermore,

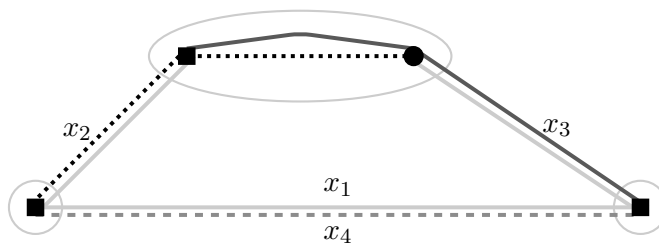

Figure 5: The Steiner partition inequality $2x_1 + x_2 + x_3 + x_4 \geq 2$ is facet defining (node sets of the Steiner partition encircled).

let \mathcal{P}_P denote the set of paths $p \in \mathcal{P}$ that contain at least two distinct shrunk nodes in G_P , in formulas

$$\mathcal{P}_P = \{p \in \mathcal{P} : \exists V_i, V_j \in V_P, V_i \neq V_j, V_i \in p, V_j \in p\},$$

and $\bar{\mathcal{P}} := \mathcal{P} \setminus \mathcal{P}_P$ its complement. Finally, $G[V_i]$ is the graph induced by the nodes V_i .

Lemma 4.4. *The Steiner partition inequality*

$$\sum_{p \in \mathcal{P}_P} a_p x_p \geq k - 1, \quad (1)$$

$$a_p := |\{i \in \{1, \dots, k\} : V_i \in V_P, V_i \in p\}| - 1$$

is valid for the Steiner connectivity polytope P_{SCP} .

The coefficient a_p , $p \in \mathcal{P}$, counts the number of shrunk nodes that p contains minus one, i.e., a_p is the maximum number of edges that p can contribute to a spanning tree in G_P . The number a_p can be smaller than the number of times that p crosses the multi-cut induced by the Steiner partition.

Note that the inequality can also be stated as $\sum_{p \in \mathcal{P}} a_p x_p \geq k - 1$, because $a_p = 0$ for $p \notin \mathcal{P}_P$. If $k = 2$, the partition inequality is a Steiner path cut constraint. An example of a (facet defining) Steiner partition inequality can be seen in Figure 5.

Proof of Lemma 4.4. We have to show that each 0/1-solution x^* of the Steiner connectivity problem satisfies

$$\sum_{p \in \mathcal{P}_P} a_p x_p^* \geq k - 1.$$

Consider the solution x^* on the shrunk graph G_P . Since each node set V_i , $i = 1, \dots, k$, contains a terminal node, the shrunk graph G_P has to be connected by the solution x^* , i.e., the (paths of the) support of x^* must contain a spanning tree in G_P . This means that the support of x^* contains at least $k - 1$ edges in G_P . \square

The following two propositions give sufficient and necessary conditions for a Steiner partition inequality to be facet defining for the SCP. The sufficient conditions are analogous to those for the Steiner tree polytope, see Grötschel and Monma [23]. Recall $\bar{\mathcal{P}} = \mathcal{P} \setminus \mathcal{P}_P$.

Proposition 4.5. *A Steiner partition inequality is facet defining if the following properties are satisfied.*

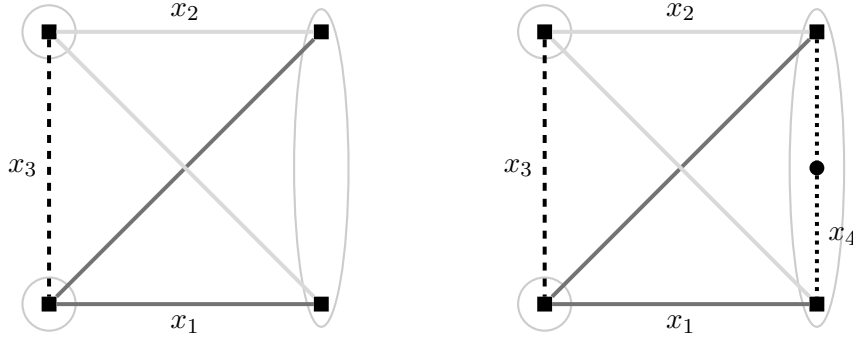

Figure 6: Examples of facet defining Steiner partitions that do not satisfy properties 1 (left) and 2 (right) of Proposition 4.5. In both examples the Steiner partition consists of three node sets which are marked gray. The square (terminal) nodes have to be connected.

1. $G[V_i]$ is connected by $\bar{\mathcal{P}}$, $i = 1, \dots, k$.
2. $G[V_i]$ contains no Steiner path bridge in $\bar{\mathcal{P}}$, i.e., there is no Steiner path cut $\mathcal{P}_{\delta(W)} \subseteq \bar{\mathcal{P}}$ with $|\mathcal{P}_{\delta(W)}| = 1$ for $W \subseteq V_i$, $\emptyset \neq W \cap T \neq T \cap V_i$, $i = 1, \dots, k$.
3. Each path contains at most two nodes in G_P , i.e., $a_p \in \{0, 1\}$ for all $p \in \mathcal{P}$.
4. G_P is 2-node-path-connected, i.e., if we remove any node with all adjacent paths, the resulting graph is connected. (An edge is removed if it is no longer covered by paths.)

Proof. Let $P = (V_1, \dots, V_k)$ be a Steiner partition in G and consider the corresponding partition inequality $a^T x = \sum_{p \in \mathcal{P}_P} a_p x_p \geq k - 1$. Assume that properties 1 to 4 are satisfied. Let $b^T x = \beta$ be an equation such that

$$F_a = \{x \in P_{\text{SCP}} : a^T x = k - 1\} \subseteq F_b = \{x \in P_{\text{SCP}} : b^T x = \beta\}$$

and such that F_b is a facet of P_{SCP} .

We first show that $b_p = 0$ for all $p \in \bar{\mathcal{P}}$. Since $p \in \bar{\mathcal{P}}$, p is completely contained in $G[V_j]$ for some $j \in \{1, \dots, k\}$. Let $\mathcal{P}' \subseteq \mathcal{P}_P$ be a minimal set of paths connecting G_P , i.e., for each two nodes in G_P there exists a path that is completely covered by paths in \mathcal{P}' and if we remove any path of \mathcal{P}' then there are at least two nodes in G_P that are not connected. Since all paths contain at most two different nodes of G_P (property 3), we have $|\mathcal{P}'| = k - 1$. Set $M = \mathcal{P}' \cup \bar{\mathcal{P}}$ and $M' = M \setminus \{p\}$. Since each $G[V_i]$, $i = 1, \dots, k$, is connected by paths of $\bar{\mathcal{P}}$ (property 1) and p is not a Steiner path bridge for $G[V_j]$ (property 2), $\chi^M, \chi^{M'} \in P_{\text{SCP}}$ and $a^T \chi^M = a^T \chi^{M'} = k - 1$, where χ^M is the incidence vector of M . Thus, $b^T \chi^M = b^T \chi^{M'}$ which implies $b_p = 0$.

Let $p, q \in \mathcal{P}_P$, $p \neq q$. Consider the graph $\hat{G}_P = (V_P, \mathcal{P}_P)$ in which p is an edge between V_i and V_j if it contains V_i and V_j (recall that $p \in \mathcal{P}_P$ contains exactly two nodes, see property 3). Since G_P is 2-node-path-connected, \hat{G}_P is 2-node-connected and there exists a cycle C in \hat{G}_P containing p and q . Let \mathcal{P}' be a tree in \hat{G}_P containing $C \setminus \{p\}$. Then $\mathcal{P}'' = \mathcal{P}' \setminus \{q\} \cup \{p\}$ is also a tree in \hat{G}_P . Set $M = \mathcal{P}' \cup \bar{\mathcal{P}}$ and $M' = \mathcal{P}'' \cup \bar{\mathcal{P}}$. Then $\chi^M, \chi^{M'} \in F_a$ and $0 = b^T \chi^M - b^T \chi^{M'} = b_q - b_p$. This implies that $b \in \{0, \lambda\}^{\mathcal{P}}$, $\lambda \geq 0$, using part 3 of Lemma 4.3. Hence, $b^T x$ is a multiple of $a^T x$. This proves that $a^T x \geq k - 1$ defines a facet of P_{SCP} . \square

Different from the Steiner tree case (cf. [23]), properties 1 to 3 are not necessary

in the Steiner connectivity case, see Figure 5 (property 3), Figure 6 (left: property 1, right: property 2) for examples. Property 4 is necessary, see Proposition 4.6 below.

We now derive necessary conditions. Let $\Phi_{V_i}(\mathcal{P})$ be the V_i -contraction of \mathcal{P} , i.e., contract every path $p \in \mathcal{P}$ iteratively in the following way until no reduction is possible anymore:

- If p contains the edges $\{u, v\}$ and $\{v, w\}$, and $v \notin V_i$ then contract $\{u, v\}$ and $\{v, w\}$ to $\{u, w\}$.
- If $p = (\{u_1, u_2\}, \{u_2, u_3\}, \dots, \{u_{r-1}, u_r\})$, $r \geq 2$, with $u_1 \notin V_i$ then contract p to $p = (\{u_2, u_3\}, \dots, \{u_{r-1}, u_r\})$.
- If $p = (\{u_1, u_2\}, \{u_2, u_3\}, \dots, \{u_{r-1}, u_r\})$, $r \geq 2$, with $u_r \notin V_i$ then contract p to $p = (\{u_1, u_2\}, \{u_2, u_3\}, \dots, \{u_{r-2}, u_{r-1}\})$.

Proposition 4.6. *If the Steiner partition inequality (1) is facet defining for a Steiner partition P with at least three partition sets, then the following properties have to be satisfied:*

1. *The shrunk graph G_P is 2-node-path-connected.*
2. *Either $G[V_i]$ is connected or for each two subsets V_i' and V_i'' of V_i such that $V_i' \dot{\cup} V_i'' = V_i$ and V_i' is disconnected from V_i'' , there exists a path $p \in \mathcal{P}_P$ which contains at least one node of V_i' and one node of V_i'' for all $i = 1, 2, \dots, k$.*
3. *For each $G[V_i]$ the set of paths $\Phi_{V_i}(\mathcal{P})$ does not contain a Steiner path bridge with respect to $G[V_i]$, i.e., if we remove any $\tilde{p} \in \Phi_{V_i}(\mathcal{P})$ then every two terminal nodes in $G[V_i]$ are still connected by paths of $\Phi_{V_i}(\mathcal{P}) \setminus \{\tilde{p}\}$.*
4. *If two terminal nodes s and t in some $G[V_i]$ are connected by a path $p' \in \mathcal{P}_P$, then these terminals must be also connected by $\bar{\mathcal{P}}$ or we can subdivide V_i into V_i' and V_i'' , $V_i = V_i' \dot{\cup} V_i''$, such that $s \in V_i'$, $t \in V_i''$, and V_i' and V_i'' are not connected by $\bar{\mathcal{P}}$. In the second case for each $V_j \in p'$, $V_j \neq V_i$, there exists a path $p'' \in \mathcal{P}_P$ with $V_j \notin p''$, and $V_i' \in p''$, $V_i'' \in p''$.*

Proof. In the following let $P = (V_1, \dots, V_k)$, $k \geq 3$, be a Steiner partition with corresponding partition inequality $\sum_{p \in \mathcal{P}_P} a_p x_p \geq k - 1$.

1. Assume G_P is not 2-node-path-connected. In this case there exists a node V_i in G_P which is an articulation node in the following sense: If V_i and all paths incident to V_i are removed from G_P , then the resulting graph is not connected (by the remaining paths). Suppose w.l.o.g. that V_i separates V_1, \dots, V_{i-1} from V_{i+1}, \dots, V_k . Let $G_1 = G_P[V_1, \dots, V_i]$ and $G_2 = G_P[V_i, \dots, V_k]$, see Figure 7. Let k_1 be the number of nodes of G_1 and k_2 be the number of nodes of G_2 . Recall that the number of nodes of G_P is k . Note that V_i is a node of G_1 and G_2 . Therefore we have $k = k_1 + k_2 - 1$.

We construct a smaller Steiner partition $P' = \{V_1 \cup \dots \cup V_{i-1} \cup V_i, \dots, V_k\}$ which contains all nodes of $G_2 \setminus \{V_i\}$ and all nodes of G_1 as a single node. Let the resulting Steiner partition inequality be $\sum_{p \in \mathcal{P}_{P'}} a'_p x_p \geq k_2 - 1$.

Similarly, we construct a Steiner partition $P'' = \{V_1, \dots, V_i \cup V_{i+1} \cup \dots \cup V_k\}$ which contains all nodes of $G_1 \setminus \{V_i\}$ and all nodes of G_2 as a single node. We get the partition inequality $\sum_{p \in \mathcal{P}_{P''}} a''_p x_p \geq k_1 - 1$.

The sum of these two partition inequalities is equal to the partition inequality for P . Indeed, $k_1 - 1 + k_2 - 1 = k_1 + k_2 - 2 = k - 1$, and $a'_p + a''_p = a_p$, see Figure 7. Hence, Inequality (1) does not define a facet.

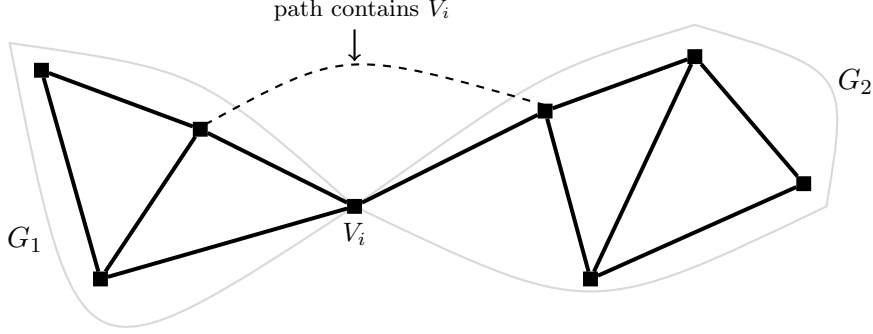

Figure 7: The graph G_P in the proof of Proposition 4.6 part 1 is not 2-node-path-connected and V_i is an articulation node. Each path that connects G_1 and G_2 (dashed in the picture) contains V_i .

2. Assume w.l.o.g. $G[V_1]$ is not connected and there exists no path connecting different components of $G[V_1]$. Let $V'_1 \subset V_1$ be the node set of one connected component of $G[V_1]$ such that $(V_1 \setminus V'_1) \cap T \neq \emptyset$. Since G is connected (and every edge is covered by at least one path) there is a node set V_j , $j \in \{2, \dots, k\}$, say V_2 , such that V'_1 and V_2 are connected by a path. We construct a new Steiner partition $P' = (V_1 \setminus V'_1, V'_1 \cup V_2, V_3, \dots, V_k)$ and get the partition inequality $\sum_{p \in \mathcal{P}_{P'}} a'_p x_p \geq k - 1$. Let $\hat{\mathcal{P}} = \{p \in \mathcal{P}_P : V'_1 \in p, V_2 \in p\}$, i.e., $\hat{\mathcal{P}}$ contains all paths that connect V'_1 and V_2 . One can easily verify that

$$a'_p = \begin{cases} a_p - 1 & \text{if } p \in \hat{\mathcal{P}} \\ a_p & \text{otherwise (since } V'_1 \text{ is not connected to } (V_1 \setminus V'_1)). \end{cases}$$

Since $|\hat{\mathcal{P}}| \geq 1$, the partition inequality for P is the sum of the partition inequality for P' and the inequalities $x_p \geq 0$ for all $p \in \hat{\mathcal{P}}$. Therefore, the partition inequality for P is not facet defining.

3. Assume there is a Steiner path bridge $\tilde{p} \in \Phi_{V_i}(\mathcal{P})$ with respect to $G[V_i]$. Let V'_i and $V''_i := V_i \setminus V'_i$ be two components of $G[V_i]$ that contain terminal nodes which are only connected by $\tilde{p} \in \Phi_{V_i}(\mathcal{P})$. Then $P' = (V_1, \dots, V'_i, V''_i, \dots, V_k)$ is a Steiner partition. Let the corresponding partition inequality be $\sum_{p \in \mathcal{P}_{P'}} a'_p x_p \geq k$. We claim that this partition inequality plus the upper bound inequality $-x_{\tilde{p}} \geq -1$ of \tilde{p} is equal to the partition inequality for P .

The partition P' only differs from P in splitting the node set V_i . Because \tilde{p} is the only path that connects V'_i and V''_i , we have $\mathcal{P}_{P'} = \mathcal{P}_P \cup \{\tilde{p}\}$. Furthermore, there is no path in \mathcal{P}_P (except \tilde{p} , if $\tilde{p} \in \mathcal{P}_P$) that contains V'_i and V''_i . Therefore the coefficients of all these paths stay the same: $a_p = a'_p$ for all $p \in \mathcal{P}_{P'} \setminus \{\tilde{p}\}$. For $\tilde{p} \in \mathcal{P}_P$ we get $a'_{\tilde{p}} = a_{\tilde{p}} + 1$.

4. Assume w.l.o.g. that there are two terminal nodes s and t in $G[V_1]$ that are connected by a path $p' \in \mathcal{P}_P$ and not connected by paths in $\bar{\mathcal{P}}$. Let V'_1 be the nodes reachable from s via paths in $\bar{\mathcal{P}}$ and $V''_1 := V_1 \setminus V'_1$. This shows that the first or the second case of the first part of the statement must hold.

Furthermore, assume w.l.o.g. that $V_2 \in p'$ and there is no path $p'' \in \mathcal{P}_P$ such that $V'_1 \in p''$, $V''_1 \in p''$, and $V_2 \notin p''$. Consider the Steiner partitions $P' := (V'_1, V''_1, V_2, \dots, V_k)$ and $P'' := (V_1 \cup V_2, V_3, \dots, V_k)$ with corresponding partition

inequalities

$$\sum_{p \in \mathcal{P}_{P'}} a'_p x_p \geq k \quad \text{and} \quad \sum_{p \in \mathcal{P}_{P''}} a''_p x_p \geq k - 2,$$

respectively. We show that 2 times the partition inequality for P is dominated by the sum of the partition inequalities for P' and P'' . For the right hand side, we obtain:

$$k + k - 2 = 2 \cdot k - 2 = 2 \cdot (k - 1).$$

For the left hand sides and $p \in \mathcal{P}$, we observe that

$$a'_p = \begin{cases} a_p + 1 & \text{if } V'_1 \in p, V''_1 \in p \\ a_p & \text{otherwise} \end{cases} \quad a''_p = \begin{cases} a_p - 1 & \text{if } V_1 \in p, V_2 \in p \\ a_p & \text{otherwise.} \end{cases}$$

We claim that $2 \cdot a_p \geq a'_p + a''_p$. Indeed, the only case in which this is not trivially satisfied is when $V'_1 \in p$ and $V''_1 \in p$ (and thus $V_1 \in p$), but $V_2 \notin p$. But this case contradicts our assumptions. \square

4.2 Separating the Steiner Partition Inequalities

Grötschel, Monma, and Stoer [24] showed that separating the Steiner partition inequalities for the Steiner tree problem is NP-hard. This implies that the separation of the Steiner partition inequalities for the Steiner connectivity problem is also NP-hard. However, we show in the following that the Steiner partition inequalities for the SCP are satisfied by all points in $P_{LP}(\text{SCP}_{arc^+}^r)|_{\mathcal{P}}$. This implies that the separation problem for a superclass of Steiner partition inequalities can be solved in polynomial time.

Theorem 4.7. $P_{LP}(\text{SCP}_{arc^+}^r)|_{\mathcal{P}}$ satisfies all Steiner partition inequalities.

Proof. Let $y^* \in P_{LP}(\text{SCP}_{arc^+}^r)$. We show that the projection $x_p^* = y_{v_p w_p}^*$ satisfies all Steiner partition inequalities.

Consider an arbitrary Steiner partition $P = (V_1, \dots, V_k)$ in G and the corresponding partition inequality $\sum_{p \in \mathcal{P}_P} a_p x_p \geq k - 1$. W.l.o.g. we assume that $r \in V_k$. Consider the following chain of inequalities

$$\sum_{p \in \mathcal{P}_P} a_p x_p^* \stackrel{(1)}{\geq} \sum_{\substack{p \in \mathcal{P}_P \\ r \in p}} a_p y_{v_p w_p}^* + \sum_{\substack{p \in \mathcal{P}_P \\ r \notin p}} a_p \sum_{a \in \delta^-(v_p)} y_a^* \stackrel{(2)}{\geq} \sum_{i=1}^{k-1} \sum_{a \in \delta^-(W_i)} y_a^* \stackrel{(3)}{\geq} k - 1,$$

where $W_i := \{t \in T \setminus \{r\} : t \in V_i\} \cup \{w_p : V_i \in p\} \cup \{v_p : V_i \in p, r \notin p\}$, for $i = 1, \dots, k - 1$.

Inequality (1): Identifying $x_p^* = y_{v_p w_p}^*$ and scaling the flow balance constraints $x_p^* = y_{v_p w_p}^* \geq \sum_{a \in \delta^-(v_p)} y_a^*$ by a_p for the paths that do not contain the root node and summing up gives (1).

Inequality (3): Each node set W_i ($i = 1, \dots, k - 1$) contains at least one terminal node, but not the root node r . Hence, the arc set $\delta^-(W_i)$ is a directed Steiner cut between root r and W_i . Therefore, $\sum_{a \in \delta^-(W_i)} y_a^* \geq 1$ must hold. Summing over all these cuts gives (3).

Inequality (2): The Steiner connectivity digraph D' contains arcs of the form (i) (r, v_p) , (ii) (v_p, w_p) , $r \in p$, (iii) (v_p, w_p) , $r \notin p$, (iv) $(w_{\bar{p}}, v_p)$, and (v) (w_p, t) . We show that all arcs in the cuts $\delta^-(W_i)$, $i = 1, \dots, k-1$, are of the form (ii) and (iv). Indeed, arcs of the other forms cannot appear in the cuts $\delta^-(W_i)$, $i = 1, \dots, k-1$:

- (i) Arcs of the form (r, v_p) only exist if $r \in p$. But then, $v_p \notin W_i$ due to the definition of W_i , i.e., $(r, v_p) \notin \delta^-(W_i)$.
- (iii) The nodes v_p and w_p are either both members or both not members of W_i . In any case, $(v_p, w_p) \notin \delta^-(W_i)$.
- (v) Arcs of the form (w_p, t) only exist if $t \in p$. If $t \in W_i$, then $t \in V_i$, and therefore $V_i \in p$. Hence $w_p \in W_i$, i.e., $(w_p, t) \notin \delta^-(W_i)$.

Denote by $\mathcal{V}_p := \{V_i : V_i \in p, i = 1, \dots, k\}$ the set of shrunk nodes contained in p ; then $|\mathcal{V}_p| - 1 = a_p$. The proof proceeds by establishing a relation between a_p and the number of times an arc entering v_p appears in the cuts $\delta^-(W_i)$, $i = 1, \dots, k-1$.

Consider an arc $(v_p, w_p) \in A'$. Then the following chain of equations holds:

$$a_p = |\mathcal{V}_p| - 1 = |\mathcal{V}_p \setminus \{V_k\}| = |\{W_i : (v_p, w_p) \in \delta^-(W_i), i = 1, \dots, k-1\}|. \quad (2)$$

Here, $(v_p, w_p) \in \delta^-(W_i)$ implies $r \in p$, i.e., $V_k \in p$ ($r \in V_k$) and this yields $|\mathcal{V}_p| - 1 = |\mathcal{V}_p \setminus \{V_k\}|$. Moreover, $(v_p, w_p) \in \delta^-(W_i)$ implies $V_i \in p$. Taking the union for $i = 1, \dots, k-1$ yields $|\mathcal{V}_p \setminus \{V_k\}| = |\{W_i : (v_p, w_p) \in \delta^-(W_i), i = 1, \dots, k-1\}|$. Multiplying Equation (2) with $y_{v_p w_p}^*$ gives

$$\begin{aligned} a_p y_{v_p w_p}^* &= |\{W_i : (v_p, w_p) \in \delta^-(W_i), i = 1, \dots, k-1\}| \cdot y_{v_p w_p}^* \\ &= \sum_{i=1}^{k-1} \sum_{(v_p, w_p) \in \delta^-(W_i)} y_{v_p w_p}^*. \end{aligned} \quad (3)$$

Consider an arc $(w_{\bar{p}}, v_p) \in A'$. Then the following chain of equations and inequalities holds

$$a_p = |\mathcal{V}_p| - 1 \geq |\mathcal{V}_p \setminus \mathcal{V}_{\bar{p}}| \geq |\{W_i : (w_{\bar{p}}, v_p) \in \delta^-(W_i), i = 1, \dots, k-1\}|. \quad (4)$$

Here, $(w_{\bar{p}}, v_p) \in A'$ implies $\mathcal{V}_p \cap \mathcal{V}_{\bar{p}} \neq \emptyset$ and this yields $|\mathcal{V}_p| - 1 \geq |\mathcal{V}_p \setminus \mathcal{V}_{\bar{p}}|$. Moreover, $(w_{\bar{p}}, v_p) \in \delta^-(W_i)$ implies $V_i \in p$ and $V_i \notin \bar{p}$. Taking the union for $i = 1, \dots, k-1$ yields $|\mathcal{V}_p \setminus \mathcal{V}_{\bar{p}}| \geq |\{W_i : (w_{\bar{p}}, v_p) \in \delta^-(W_i), i = 1, \dots, k-1\}|$. Multiplying Inequality (4) by $y_{w_{\bar{p}} v_p}^*$ gives

$$\begin{aligned} a_p y_{w_{\bar{p}} v_p}^* &\geq |\{W_i : (w_{\bar{p}}, v_p) \in \delta^-(W_i), i = 1, \dots, k-1\}| \cdot y_{w_{\bar{p}} v_p}^* \\ &= \sum_{i=1}^{k-1} \sum_{(w_{\bar{p}}, v_p) \in \delta^-(W_i)} y_{w_{\bar{p}} v_p}^*. \end{aligned} \quad (5)$$

Summing (3) and (5) over all arcs (v_p, w_p) and $(w_{\bar{p}}, v_p)$ gives Inequality (2):

$$\begin{aligned} &\sum_{\substack{p \in \mathcal{P}_P \\ r \in p}} a_p y_{v_p w_p}^* + \sum_{\substack{p \in \mathcal{P}_P \\ r \notin p}} a_p \sum_{a \in \delta^-(v_p)} y_a^* = \sum_{\substack{p \in \mathcal{P} \\ r \in p}} a_p y_{v_p w_p}^* + \sum_{\substack{p \in \mathcal{P} \\ r \notin p}} a_p \sum_{a \in \delta^-(v_p)} y_a^* \\ &= \sum_{\substack{(v_p, w_p) \in A' \\ r \in p}} a_p y_{v_p w_p}^* + \sum_{\substack{(w_{\bar{p}}, v_p) \in A' \\ r \notin p}} a_p y_{w_{\bar{p}} v_p}^* \stackrel{(3) \text{ and } (5)}{\geq} \sum_{i=1}^{k-1} \sum_{a \in \delta^-(W_i)} y_a^*. \end{aligned}$$

This shows the claim. \square

Remark 4.8. Note that the proof of Theorem 4.7 uses only the flow balance constraints for $(v_p, w_p) \in A'$ with $r \notin p$, i.e., the flow balance constraints for paths that contain the root are not necessary to derive the Steiner partition inequalities. Moreover, it is not hard to show that they have no impact on the value of the LP relaxation of (SCP_{arc+}^r) .

Proposition 4.9. *The separation problem for $P_{LP}(\text{SCP}_{arc+}^r)|_{\mathcal{P}}$ can be solved in polynomial time.*

Proof. Let $P = \{y \in \mathbb{R}^n : Ay \geq b, y \geq 0\}$ be a polyhedron, $I \subseteq \{1, \dots, n\}$, and $x^* \in \mathbb{R}^I$ be a vector. If the optimization problem for P is solvable in polynomial time then the separation problem “ $x^* \in P|_I?$ ” for the projection is solvable in polynomial time. This follows from the equivalence of optimization and separation and its consequences, see Grötschel, Lovász, and Schrijver [22] (intersect P with the affine space $y|_I = x^*$). In our case, the LP relaxation of (SCP_{arc+}^r) can be solved in polynomial time. This implies the claim. \square

A direct method to solve the separation problem for $P_{LP}(\text{SCP}_{arc+}^r)|_{\mathcal{P}}$ will be discussed in Subsection 5.2.

Corollary 4.10. *If $x^* \in P_{LP}(\text{SCP}_{cut})$ does not satisfy all Steiner partition inequalities, one can construct a cutting plane that separates x^* from the Steiner connectivity polytope in polynomial time.*

5 Solving the SCP

We have seen in the previous section that the extended formulation (SCP_{arc+}^r) implies strong inequalities for the canonical undirected cut formulation (SCP_{cut}) , e.g., the facet defining Steiner partition inequalities. However, the extended formulation (SCP_{arc+}^r) has a quadratic number $O(|\mathcal{P}|^2)$ of variables and a quadratically exponential number $O(2^{(|\mathcal{P}|^2)})$ of cuts and, as it will turn out, can therefore not be solved directly for large-scale instances. This brings up the question of how the strength of this formulation can be utilized for practical instances. In this section, we will give evidence that a heuristic separation of Steiner partition inequalities (SPI) harvests most of the potential. This *SPI separation* method is introduced in Section 5.1. To demonstrate its efficiency, we compare the undirected cut model including SPI separation with the strengthened directed cut formulation. Since the solution of the extended formulation is very time consuming and for large instances not even possible, we propose a *partial projection method* to produce a strong approximation. The idea is to lift an LP solution from the space of canonical variables to the extended space, to separate there, and to project the cut back. This algorithm is described in Section 5.2 in detail. A problem of this procedure is that the separation step is based on an exponential system of inequalities. This is as difficult as working directly with the extended formulation. We, therefore, consider a relaxation to separate cuts from a subsystem of the extended formulation. This subsystem has to be chosen in such a way that it is, on the one hand, of tractable size and, on the other hand, produces strong cuts. We discuss a possible choice of a good subsystem (found after empirically investigating several approaches) in Section 5.3. This partial projection method can be used to approximate the extended formulation. Since the extended formulation

includes not only Steiner partition inequalities but also other facet defining inequalities, the partial projection method can in principle find other types of inequalities that cannot be found by SPI separation, see the upcoming Example 5.1. However, our computational results in Section 5.4 show that the Steiner partition inequalities strengthen the undirected cut formulation as much as the partial projection cuts for nearly all instances. Indeed, the undirected cut formulation augmented by separated Steiner partition inequalities produces very strong bounds, typically with gaps less than five percent in our experiments; in lots of cases even the strongest bounds than can be computed in the given computation time.

5.1 SPI separation

We propose a heuristic to find a Steiner partition of the nodes that has a good chance to yield a violated Steiner partition inequality. It is based on a graph shrinking procedure that produces a promising Steiner partition of the nodes for the STP, see, e.g., Grötschel et al. [24] and Günlük [25]. Let $x^* \in P_{LP}(\text{SCP}_{cut})$ be some fractional solution and $\omega_e := \sum_{p \in \mathcal{P}: e \in p} x_p^*$, for all $e \in E$, be edge weights. Sort the edges as $e_1, \dots, e_{|E|}$ such that $\omega_{e_1} \geq \dots \geq \omega_{e_{|E|}}$. We now recursively shrink the graph by contracting edges in the order of decreasing weight. In a first step, we shrink edges as long as the edge weight is greater than or equal to 1 or one end node of an edge is not a terminal node. If an end node of an edge is a terminal node, the node that arises from shrinking this edge is also defined as a terminal node. After this first shrinking procedure each shrunk node contains at least one terminal node and is, therefore, also a terminal node. If the resulting shrunk graph contains more than one node, the weights of all remaining edges are smaller than 1. We then compute the resulting Steiner partition inequality. If it is violated, we can add it to the problem. If it is not violated, we shrink the edge with the largest weight in the shrunk graph and consider the Steiner partition inequality associated with the resulting graph. This procedure terminates as soon as we have found a violated cut or when the shrunk graph contains only one node.

5.2 Separating Cuts from the Extended Formulation

A direct method to use the extended formulation (SCP_{arc+}^r) to separate cuts for the undirected cut formulation (SCP_{cut}) is as follows: Let $x^* \in [0, 1]^{\mathcal{P}}$ be the point to be separated; denote $\tilde{A} = A'_p = \{(v_p, w_p) \in A' : p \in \mathcal{P}\}$ and $A'' = A' \setminus A'_p$. The separation problem is to find a vector $y \in P_{LP}(\text{SCP}_{arc+}^r)$ with $y|_{\mathcal{P}} = x^*$ or to find a separating cutting plane. Consider the following reformulation of the inequality system associated with (SCP_{arc+}^r) with $y|_{\mathcal{P}} = x^* =: y^*$:

$$\begin{aligned} \sum_{a \in \delta^-(W), a \in A''} y_a &\geq 1 - \sum_{a \in \delta^-(W), a \in \tilde{A}} y_a^* && \forall W \in \mathcal{W} \\ - \sum_{a \in \delta^-(v_p)} y_a &\geq -y_{v_p w_p}^* && \forall (v_p, w_p) \in A' \\ y_a &\geq 0 && \forall a \in A'', \end{aligned} \tag{6}$$

where $\mathcal{W} := \{W \subseteq V' \setminus \{r\} : W \cap T \neq \emptyset\}$ is the set of all directed Steiner cuts associated with root node r . By the Farkas lemma either inequality system (6) or

the following inequality system has a solution:

$$\begin{aligned}
\sum_{W \in \mathcal{W}} \left(1 - \sum_{a \in \delta^-(W), a \in \tilde{A}} y_a^* \right) \cdot \mu_W - \sum_{p \in \mathcal{P}} y_{v_p w_p}^* \pi_p &> 0 \\
\sum_{W \in \mathcal{W}: a \in \delta^-(W)} \mu_W - \sum_{p \in \mathcal{P}: a \in \delta^-(v_p)} \pi_p &\leq 0 \quad \forall a \in A'' \\
\mu_W &\geq 0 \quad \forall W \in \mathcal{W} \\
\pi_p &\geq 0 \quad \forall p \in \mathcal{P}.
\end{aligned} \tag{7}$$

The first inequality of (7) gives rise to a violated cut. Namely, if $y \notin P_{LP}(\text{SCP}_{arc+}^r)$ for $y|_{\mathcal{P}} = y^* = x^*$, then there exist π^* and μ^* which satisfy (7). In particular, we have

$$\begin{aligned}
&\sum_{W \in \mathcal{W}} \left(1 - \sum_{a \in \delta^-(W), a \in \tilde{A}} y_a^* \right) \cdot \mu_W^* - \sum_{p \in \mathcal{P}} y_{v_p w_p}^* \pi_p^* > 0 \\
\iff &\sum_{W \in \mathcal{W}} \left(1 - \sum_{(v_p, w_p) \in \delta^-(W)} x_p^* \right) \cdot \mu_W^* - \sum_{p \in \mathcal{P}} x_p^* \pi_p^* > 0.
\end{aligned}$$

Then

$$\sum_{W \in \mathcal{W}} \mu_W^* \leq \sum_{W \in \mathcal{W}} \sum_{p: (v_p, w_p) \in \delta^-(W)} \mu_W^* x_p + \sum_{p \in \mathcal{P}} \pi_p^* x_p$$

is a cutting plane that separates x^* from the Steiner connectivity polytope.

The system (7) is a feasibility problem that can be solved by minimizing the left-hand-side of the first inequality subject to the remaining system and the additional constraint $\|(\mu, \pi)\| \leq 1$, where $\|\cdot\|$ is an arbitrary norm, to bound the variables. There are $|\mathcal{P}|$ π -variables, which can be treated directly, and $O(2^{|\mathcal{P}|})$ μ -variables, which have to be treated by a column generation procedure. In each iteration, a subset of the cut system \mathcal{W} is considered. When the subset produces a positive objective value, we have found a violated cutting plane. Otherwise, we must increase the subset by generating an improving variable μ_W . Associating dual variables y_a'' , $a \in A''$, with the constraints of the feasibility problem (7), the pricing problem is to find $W \in \mathcal{W}$ such that

$$\sum_{a \in \delta^-(W), a \in A''} y_a'' < 1 - \sum_{a \in \delta^-(W), a \in \tilde{A}} y_a^*$$

or to conclude that no such W exists. This is a minimum directed Steiner cut problem.

5.3 Partial Projection

The system (6) is of exponential size and therefore difficult to handle. We consider a partial projection that is based on a relaxation of (SCP_{arc+}^r) using a subset of directed (r, t) -Steiner cut inequalities. After extensive computational experiments, the following two types of directed (r, t) -Steiner cuts turned out to be most useful: cuts that are associated with *path neighborhoods* of the terminals and of node sets arising in a shrinking procedure similar to the one described in Section 5.1. It turns out that the resulting subsystem is tractable and produces strong cuts. To this purpose we construct a nested family of path neighborhood cuts $\delta^-(W_t^i)$ where W_t^i is of the form of the node sets W_i in the proof of Theorem 4.7. The combinatorial

motivation for the choice of these cuts is that they approximate the connectivity requirement of the problem. The path neighborhoods of the first type are iteratively constructed around each terminal node except the root node and are independent of a fractional solution x^* . The path neighborhoods of the second type try to contract the graph in order to identify directed (r, t) -Steiner cuts which likely have small capacity with respect to the LP solution of the undirected formulation.

A formal description of the construction of the path neighborhoods of the first type is as follows. We first choose arbitrarily a terminal node as root node $r \in T$. Then we consider for each of the remaining terminal nodes $t \in T \setminus \{r\}$ the set $\mathcal{P}_t^0 \subseteq \mathcal{P}$ of paths that contain t , and we define the initial path neighborhood of t as the node set

$$W_t^0 := \{t\} \cup \{w_p \mid p \in \mathcal{P}_t^0\} \cup \{v_p \mid p \in \mathcal{P}_t^0, r \notin p\}.$$

Then $\delta^-(W_t^0)$ forms a directed (r, t) -cut in the Steiner connectivity digraph. In fact, it is easy to see that

$$\delta^-(W_t^0) = \{(v_p, w_p) \in A' : p \in \mathcal{P}_t^0, r \in p\} \cup \{(w_{\tilde{p}}, v_p) \in A' : \tilde{p} \notin \mathcal{P}_t^0, p \in \mathcal{P}_t^0, r \notin p\}.$$

We then choose a node $v \in V$, $\{t, v\} \in E$, such that the set of paths that contain t or v is minimal, i.e., if \mathcal{P}_v denotes the set of paths that contain node v then

$$\mathcal{P}_t^1 := \operatorname{argmin}_{v \in V, \{v, t\} \in E} |\mathcal{P}_t^0 \cup \mathcal{P}_v|,$$

and we obtain the first path neighborhood

$$W_t^1 := \{t\} \cup \{w_p \mid p \in \mathcal{P}_t^1\} \cup \{v_p \mid p \in \mathcal{P}_t^1, r \notin p\}.$$

Let $V_t^1 = \{t, v\}$ be the node set that produced the first path neighborhood. Repeating this construction, i.e., extending the node set V_t^i by an adjacent node such that the set of paths \mathcal{P}_t^i has smallest size, until all nodes are considered, produces a sequence of say $j(t) + 2$ path sets and path neighborhoods

$$\mathcal{P}_t^0 \subset \mathcal{P}_t^1 \subset \dots \subset \mathcal{P}_t^{j(t)+1} = \mathcal{P} \quad \text{and} \quad W_t^0 \subset W_t^1 \subset \dots \subset W_t^{j(t)+1},$$

with corresponding directed (r, t) -Steiner cuts

$$\delta^-(W_t^i) = \{(v_p, w_p) \in A' : p \in \mathcal{P}_t^i, r \in p\} \cup \{(w_{\tilde{p}}, v_p) \in A' : \tilde{p} \notin \mathcal{P}_t^i, p \in \mathcal{P}_t^i, r \notin p\} \quad (8)$$

for each $t \in T \setminus \{r\}$, $i = 0, \dots, |V|$. Of course, we do not have to consider all nodes for each terminal, i.e., we can choose $i < |V|$. This can be done to reduce the time and memory consumption of the partial projection method.

A formal description of the path neighborhoods arising from the shrinking procedure is as follows. Let $x^* \in P_{LP}(\text{SCP}_{cut})$ be some fractional solution in the original space of variables and $\omega_e := \sum_{p \in \mathcal{P}: e \in p} x_p^*$, for all $e \in E$, be edge weights. Then we consider for each node $v \in V$ the set \mathcal{P}_v of paths that contain node v , and define a path neighborhood of v as

$$W_v^\circ := \begin{cases} \{w_p \mid p \in \mathcal{P}_v\} \cup \{v_p \mid p \in \mathcal{P}_v, r \notin p\} \cup \{v\}, & \text{if } v \in T, \\ \{w_p \mid p \in \mathcal{P}_v\} \cup \{v_p \mid p \in \mathcal{P}_v, r \notin p\}, & \text{if } v \notin T. \end{cases}$$

Sort the edges as $e_1, \dots, e_{|E|}$ such that $\omega_{e_1} \geq \dots \geq \omega_{e_{|E|}}$. We now recursively perform two shrinking procedures. We first shrink the graph by contracting edges in the order of decreasing weight until each shrunk node contains a terminal node. Then we shrink the graph by contracting edges in the order of decreasing weight until we arrive at a single node. If nodes u and v are shrunk to a new node w , we define $\mathcal{P}_w := \mathcal{P}_u \cup \mathcal{P}_v$ and $W_w^\circ := W_u^\circ \cup W_v^\circ$. Denote by V° the set of all shrunk nodes (during the shrinking procedure) that contain a terminal node, but not the root node (the path neighborhoods of non-shrunk terminal nodes coincide with their initial path neighborhoods of the first type). Note that we can obtain shrunk nodes that do not contain a terminal node or that contain the root node, but we do not consider them in V° . Each node $v \in V^\circ$ contains a terminal t and therefore defines a directed (r, t) -Steiner cut

$$\begin{aligned} \delta^-(W_v^\circ) &= \{(v_p, w_p) \in A' : p \in \mathcal{P}_v, r \in p\} \\ &\cup \{(w_{\tilde{p}}, v_p) \in A' : \tilde{p} \notin \mathcal{P}_v, p \in \mathcal{P}_v, r \notin p\}. \end{aligned} \quad (9)$$

We use these two types of path neighborhoods as follows. Let $\mathcal{W}' := \{W_t^i \mid t \in T \setminus \{r\}, i = 0, \dots, j(t)\} \cup \{W_v^\circ \mid v \in V^\circ\}$. We propose to approximate the inequality system (6) by the subsystem

$$\begin{aligned} \sum_{a \in \delta^-(W), a \in A''} y_a &\geq 1 - \sum_{a \in \delta^-(W), a \in \tilde{A}} y_a^* && \forall W \in \mathcal{W}' \\ - \sum_{a \in \delta^-(v_p)} y_a &\geq -y_{v_p w_p}^* && \forall (v_p, w_p) \in A' \\ y_a &\geq 0 && \forall a \in A'', \end{aligned} \quad (10)$$

i.e., instead of all directed (r, t) -Steiner cuts, we consider those arising from path neighborhoods, i.e., we replace the set \mathcal{W} by \mathcal{W}' . We bound the variables of the dual of (10) by 1 in order to normalize.

The *path neighborhood cut subsystem* (10) is tractable because it contains a polynomial number $\sum_{t \in T} |V| + |V| - 1 \in O(|T| \cdot |V|)$ of cuts (each new path neighborhood of the first type reaches a new node, and there are at most $|V| - 1$ shrunk nodes). It is strong in the sense that it can produce facet defining inequalities. These include Steiner partition inequalities such as the one shown in Figure 5. In general, a Steiner partition inequality will be separated with our path neighborhood cut subsystem, if each node set of the partition satisfies the following condition: The paths that intersect the node set of a partition correspond to a path neighborhood. This is always the case for $T = V$: The Steiner partition inequality corresponding to the partition $V_t = \{t\}$, $t \in T$, can be efficiently separated. Another case is for the Steiner tree problem, i.e., all paths have length one. Our path neighborhood cut subsystem separates all Steiner partition inequalities where the node sets of the partitions correspond to some path neighborhood of a terminal. The following example shows that the path neighborhood cut subsystem implies also other types of facet defining inequalities.

Example 5.1. Figure 8 shows a facet defining inequality which is not a Steiner partition inequality. Consider the inequality $x_1 + x_2 + x_3 + x_4 \geq 2$. Because the right hand side is 2, a Steiner partition would consist of three node sets, each of which must include at least one terminal node. However, in every possible partition at least

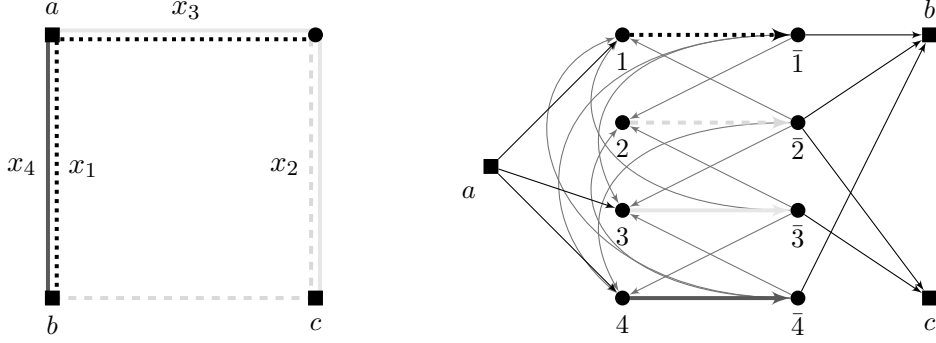

Figure 8: The inequality $x_1 + x_2 + x_3 + x_4 \geq 2$ is valid but not a partition inequality.

one path contains all three partition nodes. The SPI separation would, therefore, never find this cut.

We show that this cut can be separated with our path neighborhood cut subsystem as follows. Let $x^* \in P_{LP}(\text{SCP}_{cut})$ with $x_1^* = x_2^* = x_3^* = 0.5$ and $x_4^* = 0$. Obviously x^* satisfies all Steiner cut inequalities but not $x_1 + x_2 + x_3 + x_4 \geq 2$. Consider the path neighborhood cut subsystem (10) for the two initial path neighborhoods $W_b^0 := \{\bar{1}, 2, \bar{2}, \bar{4}, b\}$ and $W_c^0 := \{2, \bar{2}, \bar{3}, c\}$:

$$\begin{aligned}
y_{\bar{3}2} &\geq 1 - y_{\bar{1}\bar{1}}^* - y_{4\bar{4}}^* && (W_b^0) \\
y_{\bar{1}2} + y_{\bar{4}2} &\geq 1 - y_{\bar{3}\bar{3}}^* && (W_c^0) \\
-y_{a1} - y_{\bar{2}1} - y_{\bar{3}1} - y_{\bar{4}1} &\geq -y_{\bar{1}\bar{1}}^* \\
-y_{\bar{1}2} - y_{\bar{3}2} - y_{\bar{4}2} &\geq -y_{\bar{2}\bar{2}}^* \\
-y_{a3} - y_{\bar{1}3} - y_{\bar{2}3} - y_{\bar{4}3} &\geq -y_{\bar{3}\bar{3}}^* \\
-y_{a4} - y_{\bar{1}4} - y_{\bar{2}4} - y_{\bar{3}4} &\geq -y_{\bar{4}\bar{4}}^*
\end{aligned}$$

(all other path neighborhood cuts are redundant) and the corresponding dual of the path neighborhood cut subsystem (μ_t corresponds to W_t^0 , $t = b, c$)

$$\begin{aligned}
(1 - y_{\bar{1}\bar{1}}^* - y_{\bar{4}\bar{4}}^*)\mu_b + (1 - y_{\bar{3}\bar{3}}^*)\mu_c - \pi_1 \cdot y_{\bar{1}\bar{1}}^* - \pi_2 \cdot y_{\bar{2}\bar{2}}^* - \pi_3 \cdot y_{\bar{3}\bar{3}}^* - \pi_4 \cdot y_{\bar{4}\bar{4}}^* &> 0 \\
\mu_b - \pi_2 &\leq 0 \\
\mu_c - \pi_2 &\leq 0 \\
\mu_b, \mu_c &\geq 0 \\
\pi_i &\geq 0 \quad i = \{1, 2, 3, 4\}.
\end{aligned}$$

A valid solution is $\mu_b = \mu_c = 1$, $\pi_2 = 1$, and all other variables set to 0. Since $y_{\bar{1}\bar{1}}^* = x_1^* = 0.5$, $y_{\bar{2}\bar{2}}^* = x_2^* = 0.5$, $y_{\bar{3}\bar{3}}^* = x_3^* = 0.5$, and $y_{\bar{4}\bar{4}}^* = x_4^* = 0$, the value of the first inequality in this system is 0.5. This yields the cutting plane

$$(1 - x_1 - x_4) + (1 - x_3) - x_2 \leq 0 \quad \Leftrightarrow \quad x_1 + x_2 + x_3 + x_4 \geq 2.$$

It can be shown that this inequality defines a facet.

5.4 Computational Analysis

We will show now that the Steiner partition inequalities indeed significantly improve the LP relaxation of the canonical undirected cut formulation and help to solve Steiner connectivity problems. We have implemented the methods described in the

preceding subsections and tested them on six transportation networks that we denote as China, Dutch, SiouxFalls, Anaheim, Potsdam, and Chicago. Instances Anaheim, SiouxFalls, and Chicago use the graphs of the street networks with the same names from the Transportation Network Test Problems Library of Bar-Gera [38]. Instances China, Dutch, and Potsdam correspond to public transportation networks. The Dutch network was introduced by Bussieck [9] in the context of line planning. The Potsdam data were provided to us in a joint project on line planning by the local public transport company ViP Verkehrsgesellschaft Potsdam GmbH. The China instance is artificial; we constructed it as a showcase example, connecting the twenty biggest cities in China by the 2009 high speed train network.

All instances are associated with a so-called OD matrix that gives the number of passengers who want to travel between each pair of nodes. We define as terminals all stations with positive supply or demand, i.e., such that there exists a positive entry in the corresponding row or column of the OD matrix. The paths can then be interpreted as possible lines (e.g., bus lines in the street networks) to connect the terminals/OD nodes. In the Potsdam instance we distinguish between edges of different types, e.g., arcs for tram lines and arcs for bus lines. Solving the Steiner connectivity problems with costs depending on the lengths of the lines amounts to the construction of a connected line plan with minimum cost (where each line is operated once). Such a solution can be used to estimate a lower bound on the cost of a line plan.

For each network, we consider two benchmark instances of the Steiner connectivity problem. These were constructed as follows. For each network we randomly chose a set of node pairs and computed the shortest path between each pair (instances with suffix 1) and the three shortest paths between each pair (instances with suffix 2). In the Potsdam instances the edges of such a path have to be of the same type (e.g., bus, tram). For the three smallest instances (China, Dutch, and SiouxFalls) we restricted the lengths of the paths to 6 edges. For the three largest instances (Anaheim, Potsdam, and Chicago) we considered paths with at most 20 edges. These restrictions were chosen in order to avoid that only very few paths connect the whole network; very long lines are also not desired in public transport. The costs of the paths correspond to the lengths of the paths in kilometers, which is given by the lengths of the edges in the network data. The instances were reduced by some preprocessing, see [5].

Table 1 gives some statistics on these instances. It shows the number of nodes, edges, and arcs for the networks and the associated Steiner connectivity digraphs as well as the number of paths for all instances. One can see that the number of arcs of the Steiner connectivity digraph, which is the number of variables in the strengthened directed cut formulation (SCP_{arc+}^r), is nearly quadratic in the number of paths \mathcal{P} .

Table 2 presents the performance of the undirected cut formulation including SPI separation in comparison to the undirected cut formulation, the strengthened directed cut formulation, and the undirected cut formulation extended by partial projection. More precisely, the table shows the LP value and the computation time in CPU seconds for solving the LP relaxation of

- the weak cut formulation (SCP_{cut}^w),
- the strengthened directed cut formulation (SCP_{arc+}^r),

Table 1: Street and public transportation networks. The columns are as follows: name of the instance, number of terminals, number of nodes, number of edges, number of paths, and number of nodes and arcs of the associated Steiner connectivity digraph. (We inserted all terminals twice into the Steiner connectivity digraph in order to use them as sources and sinks at the same time; this speeds up the computations.) The last column gives the maximal length of a path.

| name | $ T $ | $ V $ | $ E $ | $ \mathcal{P} $ | $ V' $ | $ A' $ | $\max p $ |
|-------------|-------|-------|-------|-----------------|--------|------------|------------|
| China1 | 20 | 20 | 98 | 130 | 300 | 9 621 | 6 |
| China2 | 20 | 20 | 98 | 211 | 462 | 29 225 | 6 |
| Dutch1 | 23 | 23 | 106 | 173 | 392 | 18 582 | 6 |
| Dutch2 | 23 | 23 | 106 | 263 | 572 | 53 449 | 6 |
| SiouxFalls1 | 24 | 24 | 124 | 186 | 420 | 14 650 | 6 |
| SiouxFalls2 | 24 | 24 | 124 | 311 | 670 | 50 252 | 6 |
| Anaheim1 | 38 | 454 | 1 344 | 1 713 | 3 502 | 777 466 | 20 |
| Anaheim2 | 38 | 454 | 1 344 | 5 135 | 10 346 | 7 346 857 | 20 |
| Potsdam1 | 107 | 885 | 3 572 | 2 401 | 5 016 | 949 440 | 20 |
| Potsdam2 | 107 | 885 | 3 572 | 5 349 | 10 912 | 5 747 714 | 20 |
| Chicago1 | 386 | 909 | 3 672 | 2 546 | 5 864 | 1 419 999 | 20 |
| Chicago2 | 386 | 909 | 3 672 | 7 638 | 16 048 | 12 858 604 | 20 |

- the weak cut formulation improved by the SPI separation method ($\text{SCP}_{cut}^{w,\text{SPI}}$), and
- the weak cut formulation improved by the partial projection method (SCP_{cut+}^w).

A ‘*’ in the time column indicates that the time limit of five hours was reached. A ‘-’ indicates that this formulation exceeds the memory limit of the used computer. All computations were done with version 1.2.0 of SCIP [1, 37] on an Intel Quad-Core 2, 3.0 GHz computer (in 64 bit mode) with 6 MB cache, running Linux and 16 GB of memory. By default, we use the simplex method of CPLEX 12.1 [26] for solving LPs (in single core mode).

We initialize all formulations using the (directed) Steiner path cuts around the terminal nodes plus the following cut

$$\sum_{p \in \mathcal{P}} a_p x_p \geq |T| - 1, \quad a_p = \min\{|\{t \in T : t \in p\}|, |p|\}.$$

If all nodes are terminal nodes, this corresponds to the Steiner partition inequality where each node forms a single partition set. Then a cutting plane algorithm depending on the formulation was run until no improvement could be made or the time limit was exceeded. The partial projection method was stopped if we did not find a cut or if the LP value did not change for ten rounds of cuts by more than 1% (formulation (SCP_{cut+}^w)). For the bigger instances Anaheim, Potsdam, and Chicago, we started the partial projection after the objective value could not be improved by at least 1.5% in one round. This is done to get a better LP value for initializing the path neighborhoods of the shrinking procedure, which is not necessary for the smaller instances. To keep the path neighborhood cut subsystem within a tractable size, we considered $\mathcal{W}' := \{W_t^i \mid t \in T \setminus \{r\}, 0 \leq i \leq \max\{3, \lceil \frac{|V|}{|T|} \rceil\}\}$ for the path neighborhoods of the terminals and stopped the procedure when $|\delta^-(W_t^i)| \geq 100\,000$, $i = 0, \dots, \lceil \frac{|V|}{|T|} \rceil$. For the two big Chicago instances, we stopped the shrinking procedure for the path neighborhoods after the first shrinking step, i.e., after all nodes are contained in a partition set with at least one terminal node, see Section 5.3.

Table 2: LP values and computation time for four formulations of the Steiner connectivity problem. A ‘*’ indicates that the time limit of five hours was reached. A ‘-’ indicates that the memory limit was reached. For (SCP_{arc+}^r) we compared the running times with the barrier and with the simplex. We took the best value of both computations, for instance Potsdam1 the barrier (b) computed the best value. All other models were computed with the simplex method.

| name | (SCP_{cut}^w) | | (SCP_{arc+}^r) | | $(SCP_{cut}^{w,SPI})$ | | (SCP_{cut+}^w) | |
|-------------|-----------------|-------|------------------|------|-----------------------|------|------------------|-------|
| | value | time | value | time | value | time | value | time |
| China1 | 7906.1 | <1 | 8382.0 | 31 | 8382.0 | <1 | 8329.5 | <1 |
| China2 | 7892.8 | <1 | 8089.0 | 5 | 8089.0 | <1 | 8089.0 | <1 |
| Dutch1 | 19250.0 | <1 | 19755.7 | * | 19750.0 | <1 | 19800.0 | <1 |
| Dutch2 | 19100.0 | <1 | 19762.9 | * | 19750.0 | <1 | 19800.0 | <1 |
| SiouxFalls1 | 104.3 | <1 | 114.0 | 301 | 114.0 | <1 | 114.0 | 1 |
| SiouxFalls2 | 105.1 | <1 | 112.0 | 365 | 112.0 | <1 | 112.0 | 2 |
| Anaheim1 | 960961.1 | 2 | 964046.3 | * | 966225.6 | 4 | 966834.0 | 95 |
| Anaheim2 | 813194.1 | 45 | - | - | 829451.0 | 76 | 820391.2 | 597 |
| Potsdam1 | 260886.9 | 135 | (b) 261459.3 | * | 261196.7 | 194 | 261846.3 | 412 |
| Potsdam2 | 256106.4 | 1 242 | 250504.1 | * | 256200.2 | 799 | 256473.9 | 1 386 |
| Chicago1 | 2642.8 | 378 | 2660.6 | * | 2642.9 | 778 | 2673.1 | 8 805 |
| Chicago2 | 2198.3 | 652 | - | - | 2329.2 | * | 2298.3 | * |

Let us now analyze the results in Table 2. The advantage of the weak cut formulation (SCP_{cut}^w) is its compactness. This formulation has the smallest number of variables and inequalities. Moreover, the separation problem for the weak Steiner path cut constraints can be solved in the original undirected graph. The weak cut formulation (SCP_{cut}^w) , therefore, has the shortest computation times. We also computed the values of the LP relaxation of the cut formulation (SCP_{cut}) , but we only get a small increase of the LP value for few instances compared to the weak cut formulation (SCP_{cut}^w) , whereas the computation time of (SCP_{cut}) always takes much longer, since the separation problem requires the construction of the Steiner connectivity digraph, see the preprint [8] for more details. We therefore do not present results for (SCP_{cut}) . However, the Steiner connectivity digraph can be used to improve the LP bound significantly via the strengthened cut formulation (SCP_{arc+}^r) . The weakness of this model are the long computation times and the memory consumption, since it uses the arcs of the Steiner connectivity digraph as variables. Note that the size of the Steiner connectivity digraph depends on the number and length of paths in the original graph, which can become very large. For this reason, the strongest formulation, the strengthened directed cut formulation (SCP_{arc+}^r) , becomes practically intractable for large problems. Its LP value could not be computed for Anaheim2 and for Chicago2, because of the excessive memory consumption. Model (SCP_{cut+}^w) combines the compactness of the weak cut formulation with the quality of the strengthened directed cut formulation. The results show that (SCP_{cut+}^w) indeed approximates the strengthened directed cut formulation very well. Its memory consumption can be controlled via the definition of the considered cuts. Its LP value can therefore be computed for all instances. Considering the LP value of model $(SCP_{cut}^{w,SPI})$, it becomes apparent that most of the strength of the directed cut formulation can also be achieved by separating Steiner partition inequalities as described in Section 5.1. For seven instances the LP bounds of model $(SCP_{cut}^{w,SPI})$ are as good as

Table 3: Solving (SCP_{cut}^w) with branch-and-cut using SCIP. The time is given in seconds; a ‘*’ indicates that the computation time of 10 hours was reached.

| name | bb nodes | time | dual bound | primal solution | gap |
|-------------|----------|------|------------|-----------------|--------|
| China1 | 49 | <1 | 8382.0 | 8382 | 0.00% |
| China2 | 19 | <1 | 8089.0 | 8089 | 0.00% |
| Dutch1 | 31 | <1 | 198.0 | 198 | 0.00% |
| Dutch2 | 19 | <1 | 198.0 | 198 | 0.00% |
| SiouxFalls1 | 2 903 | 23 | 114.0 | 114 | 0.00% |
| SiouxFalls2 | 497 | 7 | 112.0 | 112 | 0.00% |
| Anaheim1 | 235 | 48 | 976603.0 | 976603 | 0.00% |
| Anaheim2 | 52 657 | * | 824699.0 | 844237 | 2.37% |
| Potsdam1 | 13 910 | * | 261928.0 | 271988 | 3.84% |
| Potsdam2 | 4 385 | * | 256941.4 | 270179 | 5.15% |
| Chicago1 | 686 | * | 2689.0 | 2806 | 4.35% |
| Chicago2 | 184 | * | 2214.2 | 2778 | 25.47% |

Table 4: Solving (SCP_{cut+}^w) with branch-and-cut using SCIP. The time is given in seconds; a ‘*’ indicates that the computation time of 10 hours was reached.

| name | bb nodes | time | dual bound | primal solution | gap |
|-------------|----------|--------|------------|-----------------|--------|
| China1 | 1 | <1 | 8382.0 | 8382 | 0.00% |
| China2 | 1 | <1 | 8089.0 | 8089 | 0.00% |
| Dutch1 | 3 | <1 | 198.0 | 198 | 0.00% |
| Dutch2 | 6 | <1 | 198.0 | 198 | 0.00% |
| SiouxFalls1 | 1 | 2 | 114.0 | 114 | 0.00% |
| SiouxFalls2 | 1 | 2 | 112.0 | 112 | 0.00% |
| Anaheim1 | 150 | 280 | 976603.0 | 976603 | 0.00% |
| Anaheim2 | 3 635 | 11 683 | 831749.0 | 831749 | 0.00% |
| Potsdam1 | 10 342 | * | 262569.1 | 270530 | 3.03% |
| Potsdam2 | 2 933 | * | 257198.9 | 268467 | 4.38% |
| Chicago1 | 279 | * | 2703.1 | 2939 | 8.73% |
| Chicago2 | 6 | * | 2303.7 | 2980 | 29.35% |

the LP bounds of (SCP_{arc+}^r) or (SCP_{cut+}^w) ; for two instances $(SCP_{cut}^{w,SPI})$ even yields the best LP bounds that can be computed within the given time limit. The results imply that the Steiner partition inequalities are the key to improve the undirected cut formulation for most Steiner connectivity instances. Model $(SCP_{cut}^{w,SPI})$ provides an easy and time-saving way to utilize them computationally, models (SCP_{arc+}^r) and (SCP_{cut+}^w) provide quality certificates in terms of strong lower bounds.

We also used a branch-and-cut method to solve the Steiner connectivity problem for the six test instances. We used the default heuristics of SCIP and the strong branching rule, plus a greedy type heuristic for the Steiner connectivity problem based on LP values. In this heuristic, we sort the paths in decreasing order of their LP value. We then repeatedly choose the path with the smallest value and fix it to zero if the network is still connected. Otherwise, the path is fixed to one. The procedure terminates when all paths are fixed. We limit the computation time for each instance to 10 hours. The results for the models (SCP_{cut}^w) , (SCP_{cut+}^w) , and $(SCP_{cut}^{w,SPI})$ are shown in Table 3, 4, and 5.

Table 5: Solving $(SCP_{cut}^{w,SPI})$ with branch-and-cut using SCIP. The time is given in seconds; a ‘*’ indicates that the computation time of 10 hours was reached.

| name | bb nodes | time | dual bound | primal solution | gap |
|-------------|----------|------|------------|-----------------|--------|
| China1 | 11 | <1 | 8382.0 | 8382 | 0.00% |
| China2 | 1 | <1 | 8089.0 | 8089 | 0.00% |
| Dutch1 | 32 | <1 | 198.0 | 198 | 0.00% |
| Dutch2 | 15 | <1 | 198.0 | 198 | 0.00% |
| SiouxFalls1 | 1 | <1 | 114.0 | 114 | 0.00% |
| SiouxFalls2 | 1 | <1 | 112.0 | 112 | 0.00% |
| Anaheim1 | 124 | 30 | 976603.0 | 976603 | 0.00% |
| Anaheim2 | 1 | 158 | 831749.0 | 831749 | 0.00% |
| Potsdam1 | 14 295 | * | 262027.8 | 269834 | 2.98% |
| Potsdam2 | 3 463 | * | 256993.5 | 269407 | 4.83% |
| Chicago1 | 584 | * | 2687.6 | 2806 | 4.41% |
| Chicago2 | 72 | * | 2332.5 | 2772 | 18.84% |

The instances China, Dutch, SiouxFalls, and Anaheim1 can be solved by all three formulations. $(SCP_{cut}^{w,SPI})$ and (SCP_{cut+}^w) need much less nodes than (SCP_{cut}^w) . Anaheim2 can also be solved by $(SCP_{cut}^{w,SPI})$ and (SCP_{cut+}^w) but not by (SCP_{cut}^w) within the given time limit. $(SCP_{cut}^{w,SPI})$ performs best on Anaheim2, it solves the problem in the root node within seconds. Model $(SCP_{cut}^{w,SPI})$ finds the best solutions for nearly all instances; for Potsdam2 the partial projection method finds a better solution. The gap for all instances can be reduced, for Potsdam1, Potsdam2, and Chicago1 the gap is below 5%. This shows that indeed large scale Steiner connectivity problems can be solved to optimality or near optimality.

6 Conclusions

This paper has discussed the relative strengths of different formulations of the Steiner connectivity problem, namely, the undirected and the directed cut formulation in several variants. If we take the corresponding LP relaxations as a measure of strength, we obtain the following picture:

$$P_{LP}(SCP_{cut}^w) \supseteq P_{LP}(SCP_{cut}) = P_{LP}(SCP_{arc})|_{\mathcal{P}} \supseteq \frac{P_{LP}(SCP_{cut}^{SPI})}{P_{LP}(SCP_{cut+}^w)} \supseteq P_{LP}(SCP_{arc+}^r)|_{\mathcal{P}},$$

$$P_{LP}(SCP_{cut}^w) \supseteq \frac{P_{LP}(SCP_{cut}^{w,SPI})}{P_{LP}(SCP_{cut+}^w)} \supseteq P_{LP}(SCP_{arc+}^r)|_{\mathcal{P}}.$$

Here, (SCP_{cut}^{SPI}) and (SCP_{cut+}^w) denote the cut formulation including SPI separation and partial projection, respectively. As (SCP_{cut}) is so hard to compute, we resorted to the associated weak versions $(SCP_{cut}^{w,SPI})$ and (SCP_{cut+}^w) , see the second line of inclusions. SPI separation and partial projection lead to incomparable formulations: The latter might produce only part of the or different SPIs, but some additional inequalities not covered by the former. The tightest formulation is produced by the extended formulation (SCP_{arc+}^r) .

In practice, however, the strongest formulation does not necessarily produce the best results, because there is a tradeoff between the strength of a dual bound and the time needed to compute it. The ranking depends on the time limit and whether we compute an LP bound or an IP value. If the goal is to produce the best bound (including branching) a good choice is formulation $(SCP_{cut}^{w, SPI})$. Neither the tightest formulation (SCP_{arc+}^r) nor the related formulation (SCP_{cut+}^w) dominate the other formulations – although (SCP_{cut+}^w) is close to $(SCP_{cut}^{w, SPI})$. In a sense, this result confirms the general experience that extended formulations have strong theoretical properties, but they do not necessarily provide formulations well suited for practical computations – more research is needed to understand this behavior.

In the context of line planning, the Steiner connectivity problem corresponds to computing a cost minimal line plan for a given line pool, ignoring capacities. Variants of the problem in which the paths \mathcal{P} are not given in advance, but are defined implicitly via some side constraints, are interesting as well. In line planning, this would correspond to a dynamic generation of lines.

Acknowledgements We thank two anonymous referees and the editor for helpful comments and suggestions that improved the presentation of this paper.

References

- [1] Tobias Achterberg. SCIP: Solving Constraint Integer Programs. *Math. Programming Computation*, 1(1):1–41, 2009.
- [2] Ananataram Balakrishnan, Thomas L. Manganti, and Prakash Mirchandani. Network design. In M. Dell’Amico, F. Maffioli, and S. Martello, editors, *Annotated Bibliographies in Combinatorial Optimization*, chapter 18, pages 311–334. Wiley, Chichester, 1997.
- [3] Egon Balas, Sebastian Ceria, and Gerard Cornuéjols. A lift-and-project cutting plane algorithm for mixed 0-1 programs. *Math. Prog.*, 58:295–324, 1993.
- [4] Egon Balas and Shu Ming Ng. On the set covering polytope: I. All the facets with coefficients in $\{0,1,2\}$. *Mathematical Programming*, 43:57–69, 1989.
- [5] Ralf Borndörfer, Martin Grötschel, and Marc E. Pfetsch. A column-generation approach to line planning in public transport. *Transportation Science*, 41(1):123–132, 2007.
- [6] Ralf Borndörfer and Marika Neumann. Linienoptimierung – reif für die Praxis? ZIB-Report 10-20, Zuse Institute Berlin, 2010.
- [7] Ralf Borndörfer and Marika Neumann. Models for line planning with transfers. ZIB-Report 10-11, Zuse Institute Berlin, 2010.
- [8] Ralf Borndörfer, Marika Neumann, and Marc E. Pfetsch. The Steiner connectivity problem. ZIB-Report 09-07, Zuse Institute Berlin, 2009. <http://opus.kobv.de/zib/volltexte/2009/1166/>.
- [9] Michael Bussieck. Gams – lop.gms: Line optimization. <http://www.gams.com/modlib/libhtml/lop.htm>.

- [10] Michael R. Bussieck. *Optimal lines in public rail transport*. PhD thesis, TU Braunschweig, 1997.
- [11] Michael R. Bussieck, Peter Kreuzer, and Uwe T. Zimmermann. Optimal lines for railway systems. *Eur. J. Oper. Res.*, 96(1):54–63, 1997.
- [12] Michael R. Bussieck, Thomas Lindner, and Marco E. Lübbecke. A fast algorithm for near optimal line plans. *Math. Methods Oper. Res.*, 59(2), 2004.
- [13] Sunil Chopra and M. Rao. The Steiner tree problem I: Formulations, compositions and extension of facets. *Mathematical Programming*, 64(2):209–229, 1994.
- [14] M. T. Claessens, N. M. van Dijk, and P. J. Zwaneveld. Cost optimal allocation of rail passenger lines. *Eur. J. Oper. Res.*, 110(3):474–489, 1998.
- [15] Michele Conforti, Gérard Cornuéjols, and Giacomo Zambelli. Extended formulations in combinatorial optimization. *4OR*, 8:1–48, 2010.
- [16] Gerard Cornuéjols. *Combinatorial Optimization: Packing and Covering*. CBMS-NSF regional conference series in applied mathematics; 74. SIAM, Berlin, 2001.
- [17] Annegret Dix. Das statische Linienplanungsproblem. Diploma thesis, TU Berlin, 2007.
- [18] Cee W. Duin. *Steiner’s problem in graphs*. PhD thesis, University of Amsterdam, 1993.
- [19] Uriel Feige. A threshold of $\ln n$ for approximating set-cover. *Proceedings of the 28th ACM Symposium on Theory of Computing*, pages 314–318, 1996.
- [20] Jon Feldman and Matthias Ruhl. The directed steiner network problem is tractable for a constant number of terminals. In *IEEE Symposium on Foundations of Computer Science*, pages 299–308, 1999.
- [21] Monia Giandomenico, Adam N. Letchford, Fabrizio Rossi, and Stefano Smriglio. An application of the Lovász-Schrijver $M(K, K)$ operator to the stable set problem. *Mathematical Programming*, 120(2):381–401, 2009.
- [22] Martin Grötschel, László Lovász, and Alexander Schrijver. *Geometric Algorithms and Combinatorial Optimization*, volume 2 of *Algorithms and Combinatorics*. Springer, 1988.
- [23] Martin Grötschel and Clyde L. Monma. Integer polyhedra arising from certain network design problems with connectivity constraints. *SIAM Journal on Discrete Mathematics*, 3(4):502–523, 1990.
- [24] Martin Grötschel, Clyde L. Monma, and Mechthild Stoer. Computational results with a cutting plane algorithm for designing communication networks with low-connectivity constraints. *Operations Research*, 40:309–330, 1992.
- [25] Oktay Günlük. A branch-and-cut algorithm for capacitated network design problems. *Mathematical Programming*, 86:17–39, 1999.

- [26] IBM. ILOG CPLEX. <http://www-01.ibm.com/software/integration/optimization/cplex/>.
- [27] Thorsten Koch and Alexander Martin. Solving Steiner tree problems in graphs to optimality. *Networks*, 32:207–232, 1998.
- [28] László Lovász and Alexander Schrijver. Cones of matrices and set-functions and 0-1 optimization. *SIAM Journal on Optimization*, 1:166–190, 1991.
- [29] Karl Nachtigall and Karl Jerosch. Simultaneous network line planning and traffic assignment. In Matteo Fischetti and Peter Widmayer, editors, *ATMOS 2008 - 8th Workshop on Algorithmic Approaches for Transportation Modeling, Optimization, and Systems*, Dagstuhl, Germany, 2008. Schloss Dagstuhl - Leibniz-Zentrum für Informatik, Germany.
- [30] Yves Pochet and Laurence A. Wolsey. *Production Planning by Mixed Integer Programming*. Springer, New York, 2006.
- [31] Tobias Polzin. *Algorithms for the Steiner Problems in Networks*. PhD thesis, University of Saarland, Saarbrücken, 2003.
- [32] Tobias Polzin and Siavash Vahdati Daneshmand. A comparison of Steiner tree relaxations. *Discrete Applied Mathematics*, 112:241–261, 2001.
- [33] Hans Jürgen Prömel and Angelika Steger. *The Steiner Tree Problem*. Vieweg, Braunschweig/Wiesbaden, 2002.
- [34] S. Raghavan and Thomas L. Magnanti. Network connectivity. In Mauro Dell’Amico, Francesco Maffioli, and Silvano Martello, editors, *Annotated Bibliographies in Combinatorial Optimization*, pages 335–354. Wiley, Chichester, 1997.
- [35] Anita Schöbel and Susanne Scholl. Line planning with minimal traveling time. In Leo G. Kroon and Rolf H. Möhring, editors, *5th Workshop on Algorithmic Methods and Models for Optimization of Railways*, Dagstuhl, Germany, 2006. Internationales Begegnungs- und Forschungszentrum für Informatik (IBFI), Schloss Dagstuhl, Germany.
- [36] Susanne Scholl. *Customer-Oriented Line Planning*. PhD thesis, Universität Göttingen, 2005.
- [37] SCIP – Solving Constraint Integer Programs. <http://scip.zib.de>.
- [38] Transportation network test problems. <http://www.bgu.ac.il/~bargera/tntp/>.
- [39] Luis M. Torres, Ramiro Torres, Ralf Borndörfer, and Marc E. Pfetsch. Line planning on paths and tree networks with applications to the Quito Trolebús System. *Int. Trans. Oper. Res.*, 18(455–472), 2011.
- [40] François Vanderbeck and Laurence Wolsey. Reformulation and decomposition of integer programs. In Michael Jünger, Thomas Liebling, Denis Naddef, George L.

Nemhauser, William Pulleyblank, Gerhard Reinelt, Giovanni Rinaldi, and Laurence Wolsey, editors, *50 Years of Integer Programming 1958–2008*, chapter 13, pages 431–502. Springer Verlag, Berlin Heidelberg, 2010.