

ANDREAS BRANDT MANFRED BRANDT

**On the Moments of the Overflow and
Freed Carried Traffic for the
GI/M/C/0 System**

On the Moments of the Overflow and Freed Carried Traffic for the $GI/M/C/0$ System¹

Andreas Brandt

*Wirtschaftswissenschaftliche Fakultät, Humboldt-Universität zu Berlin,
Spandauer Str. 1, D-10178 Berlin, Germany*

Manfred Brandt

*Konrad-Zuse-Zentrum für Informationstechnik Berlin (ZIB),
Takustr. 7, D-14195 Berlin, Germany*

Abstract

In circuit switching networks call streams are characterized by their mean and peakedness (two-moment method). The $GI/M/C/0$ system is used to model a single link, where the GI -stream is determined by fitting moments appropriately. For the moments of the overflow traffic of a $GI/M/C/0$ system there are efficient numerical algorithms available. However, for the moments of the freed carried traffic, defined as the moments of a virtual link of infinite capacity to which the process of calls accepted by the link (carried arrival process) is virtually directed and where the virtual calls get fresh exponential i.i.d. holding times, only complex numerical algorithms are available. This is the reason why the concept of the freed carried traffic is not used rigorously. The main result of this paper is an efficient algorithm for computing the moments of the freed carried traffic, in particular an explicit formula for its peakedness. This result offers a unified handling of both overflow and carried traffics in networks. Furthermore, some refined characteristics for the overflow and freed carried streams are derived.

Mathematics Subject Classification (MSC 2000): 60K25, 68M20, 60G10, 39A10.

Keywords: $GI/M/C/0$ system; overflow traffic; freed carried traffic; carried arrival process; factorial moments; peakedness; two-moment method; difference equations.

1 Introduction and main results

In teletraffic engineering a call stream arriving at a link in a circuit switching network can be described by a stationary point process $\Phi = \{T_n\}_{n=-\infty}^{\infty}$ on the real line \mathbb{R} with $\dots < T_0 \leq 0 < T_1 < \dots$, cf. e.g. [FKAS], [BFL]. Some

¹This work was supported by a grant from the Siemens AG.

characterization of such streams is given by their mean M and peakedness Z , i.e. by their first two moments, cf. e.g. [Gira]. More precisely: directing a stream Φ virtually to an infinite trunk group with exponential holding times (parameter μ), i.e. considering a $G/M/\infty$ system, the factorial moments $M_{(k)}$, $k \in \mathbb{N} := \{1, 2, \dots\}$, of the distribution of the number of occupied trunks give some characterization of Φ . The mean M and peakedness Z are defined by $M := M_{(1)}$, $Z := 1 - M_{(1)} + M_{(2)}/M_{(1)}$ (variance-to-mean ratio). For a given mean M , the peakedness Z varies within the interval $[Z_{min}(M), \infty)$, where $Z_{min}(M) := (1 - \exp(-M^{-1}))^{-1} - M$, cf. [v.Do] p. 3, [FK]. It is well known that trunk group blocking probabilities of peaky traffic ($Z > 1$) such as overflow traffic can be substantially larger than those seen by a Poisson traffic ($Z = 1$) with the same intensity. The opposite situation occurs in case of smooth traffic ($Z < 1$). Thus there is a need of working with two-moment characterizations of streams. (For the use of higher moments in applications cf. [Rene], [KB].) If Φ is a renewal process (GI -stream) with interarrival time distribution $A(t)$ then the $M_{(k)}$ are given by, cf. e.g. [Tak1], [Tak3] or [GK] p. 81,

$$M_{(k)} = \frac{1}{\mu EA} \prod_{j=1}^{k-1} \frac{jA^*(j\mu)}{1 - A^*(j\mu)}, \quad k \in \mathbb{N}, \quad (1.1)$$

where $A^*(s)$ denotes the LST of $A(t)$ and $EA = -A^*(0)$ is the mean inter-arrival time.

Consider now a single link of capacity C as a basic component of a switching network, where a GI -stream Φ with interarrival time distribution $A(t)$ arrives, cf. Figure 1.1. Each call requires one trunk for an exponential holding time with parameter μ , i.e., the link is modelled as a $GI/M/C/0$ loss system, cf. [Gira] pp. 90/91. One justification of the GI -stream assumption is that overflow processes of GI -streams are GI -streams, too, cf. [Gira] p. 91, and that overflow streams generally can be well approximated by interrupted Poisson processes (IPP's) which are special GI -processes. As mentioned above, the overflow process $\Phi_1 = \{T_{1,n}\}_{n=-\infty}^{\infty}$ of all arrival times of calls finding at their arrival the C trunks busy is a renewal process, too, whose spacing distribution is well known, cf. [Tak1] p. 185 or [GK] p. 81. The arrival times of all calls accepted by the link provide the process $\Phi_2 = \{T_{2,n}\}_{n=-\infty}^{\infty}$ of the carried traffic by the link, cf. Figure 1.1, which can be described by means of a semi-Markov process and is of a more complex structure, cf. [HH]. Assume that the $GI/M/C/0$ system is in steady state.

Overflow traffic Φ_1 . Directing Φ_1 to an overflow link of infinite capacity and exponential holding times (parameter μ), the factorial moments $M_{1,(k)}$,

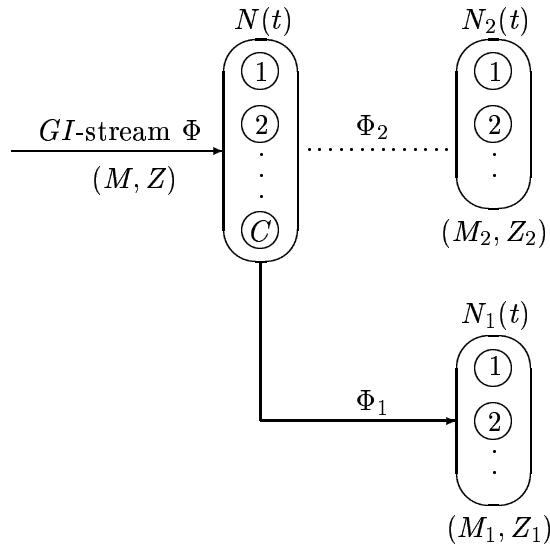

Figure 1.1: *Link of capacity C with overflow and freed carried traffic. The dotted line hints that the accepted calls at the link generate virtual calls with independent holding times.*

$k \in \mathbb{N}$, of the number $N_1(t)$ of calls in the overflow link, in particular the mean M_1 and peakedness Z_1 , give some characterization of Φ_1 . Potter, cf. [Pott] Eq. (41), proved the formula

$$\frac{1}{M_{1,(k)}} = \sum_{\ell=0}^C \binom{C}{\ell} \frac{(k+\ell-1)!}{(k-1)! M_{(\ell+k)}}, \quad k \in \mathbb{N}, \quad (1.2)$$

where the factorial moments $M_{(k)}$, $k \in \mathbb{N}$, of Φ are given by (1.1). Formula (1.2) offers a very efficient way for calculating M_1 and Z_1 .

Carried traffic Φ_2 . The corresponding characterization of Φ_2 is obtained by directing Φ_2 virtually to an infinite trunk group with exponential holding times (parameter μ) which are *independent* of the holding times at the link considered, cf. Figure 1.1.¹ The factorial moments $M_{2,(k)}$, $k \in \mathbb{N}$, of the number $N_2(t)$ of calls in the virtual link, in particular the mean M_2 and peakedness Z_2 , give some characterization of Φ_2 . This concept gave raise to call Z_2 the peakedness of the *freed carried traffic*, cf. [v.Do], in contrast

¹This means, although carried arrivals are accepted simultaneously at the $GI/M/C/0$ system and the infinite trunk group, the departure times are different.

to the variance-to-mean ratio \bar{Z}_2 of the number $N(t)$ of busy trunks on the $GI/M/C/0$ system, a quantity which is discussed and used in [Wilk], [Katz], [Desc], [Gira] and which we call *non-freed carried traffic*. It were [HH] who observed the incommensurability of Z_1 and \bar{Z}_2 when working with two-moment characterizations of streams, and that \bar{Z}_2 and Z_2 may differ considerably even in case of a Poisson arrival stream. In their paper a complex numerical algorithm for computing Z_2 is developed. However, the complexity and numerical instabilities of this algorithm, cf. Remark 3.1, prevented a rigorous use of the concept of the freed carried traffic, although this would be necessary as mentioned in [Gira] p.111: "In practice, calculating these moments (M_2 and Z_2 : *added by the authors*) is quite difficult both theoretically and numerically, and great care must be taken to ensure stability. For these reasons, the *CAP* (*freed carried traffic: added by the authors*) is not used in network-analysis algorithms." Therefore in practice the concept of the non-freed carried traffic, i.e. M_2 , \bar{Z}_2 , is used, cf. [Katz], [Desc]. The main aim of this paper is to derive new formulae – for our best knowledge – for the factorial moments $M_{2,(k)}$, $k \in \mathbb{N}$, of the freed carried traffic of a $GI/M/C/0$ system, in particular we derive the representation

$$M_{2,(2)} = M_{2,(1)} \frac{M_{(2)}}{M_{(1)}} - M_{1,(1)} M_{1,(2)} \sum_{\ell=1}^C \binom{C}{\ell} \frac{\ell!}{M_{(\ell+1)}} \sum_{m=1}^{\ell} \left(\frac{m M_{(m)}}{M_{(m+1)}} + 1 \right), \quad (1.3)$$

where because of the conservation principle $M_{2,(1)} = M_{(1)} - M_{1,(1)}$, and $M_{1,(1)}$, $M_{1,(2)}$ are given by (1.2). The representations (1.2), (1.3) provide very efficient and numerically stable algorithms. For example, in case of a Pentium processor with 200 MHz and IPP interarrival times, computing the means and peakedness factors for the overflow and freed carried traffic takes approximately 2 ms for $C = 10\,000$. The complexity of the computation is $\mathcal{O}(C)$. Thus the results of this paper offer a unified handling of both overflow and carried traffic in networks and are closing – to our best knowledge – this long existing gap.

The paper is organized as follows. In Section 2 we present a unified approach to both overflow and freed carried traffic by considering the balance equations for the densities of the triples of the backward recurrence time $R(t)$ of Φ , $N(t)$ and $N_i(t)$, $i = 1, 2$, respectively. For the partial factorial moments of the $N_i(t)$, $i = 1, 2$, which are more refined characteristics than the $M_{i,(k)}$, $i = 1, 2$, we derive explicit resp. recursive expressions (Theorem 2.1). These results seem to be new also in case of overflow streams. As an immediate

consequence, in Section 3 we obtain Eq. (1.2) and recursive expressions for the $M_{2,(k)}$, $k \in \mathbb{N}$. Using the latter we prove Eq. (1.3). In particular, we obtain the very simple expression (3.9) for the peakedness of the freed carried traffic in case of a Poisson arrival stream. In Section 4 we present numerical results illustrating the usefulness of (1.3).

2 A unified approach to overflow and freed carried traffic characteristics

Assume that the $GI/M/C/0$ system is in steady state. The stationary process $N(t)$ has the state space $\mathbb{X} := \{0, 1, \dots, C\}$, and the stationary processes $N_i(t)$, $i \in I := \{1, 2\}$, have the same state space \mathbb{Z}_+ . For $k \in \mathbb{N}$ the k th factorial moments are defined by $M_{(k)} := E(N(t) \cdot \dots \cdot (N(t) + 1 - k))$ and $M_{i,(k)} := E(N_i(t) \cdot \dots \cdot (N_i(t) + 1 - k))$, $i \in I$, respectively. The backwards recurrence time of Φ at t , i.e. the time elapsed since the last arrival at the $GI/M/C/0$ system before t , is given by

$$R(t) = \sum_{n \in \mathbb{Z}} (t - T_n) \mathbb{I}\{T_n \leq t < T_{n+1}\}.$$

The stationary processes $X_i(t) := (R(t), N(t), N_i(t))$, $t \in \mathbb{R}$, $i \in I$, have the same state space $\mathbb{R}_+ \times \mathbb{X} \times \mathbb{Z}_+$ and possess the Markov property. For $(x, n, m) \in \mathbb{R}_+ \times \mathbb{X} \times \mathbb{Z}_+$ let

$$P_i(x, n, m) := P(R(t) \leq x, N(t) = n, N_i(t) = m), \quad i \in I,$$

be their marginal distributions and

$$p_i(x, n, m) := \frac{d}{dx} P_i(x, n, m), \quad i \in I,$$

their densities. For a smooth mathematical treatment of the balance equations determining the densities $p_i(x, n, m)$ it is convenient to assume that there exists a continuous hazard rate $r(x) = A'(x)/(1 - A(x))$. Later we may drop this assumption. The dynamics of the Markov processes $X_i(t)$ provide the balance equations for the $p_i(x, n, m)$. In case of $x \in (0, \infty)$ and $(n, m) \in \mathbb{X} \times \mathbb{Z}_+$ for $i \in I$ it holds

$$\begin{aligned} p_i(x+h, n, m) &= p_i(x, n, m)(1 - (n+m)\mu h - r(x)h) \\ &\quad + p_i(x, n+1, m)(n+1)\mu h \\ &\quad + p_i(x, n, m+1)(m+1)\mu h + o(h), \quad h > 0, \end{aligned}$$

which yields

$$\begin{aligned} \frac{d}{dx} p_i(x, n, m) &= (n+1)\mu p_i(x, n+1, m) + (m+1)\mu p_i(x, n, m+1) \\ &\quad - ((n+m)\mu + r(x)) p_i(x, n, m), \end{aligned} \quad (2.1)$$

where $p_i(x, n, m) := 0$ for $(x, n, m) \notin \mathbb{R}_+ \times \mathbb{X} \times \mathbb{Z}_+$. In case of $x = 0$ and $(n, m) \in \mathbb{X} \times \mathbb{Z}_+$ we have the differing boundary conditions

$$\begin{aligned} p_i(0, n, m) &= \int_{\mathbb{R}_+} \left(p_i(y, n-1, m - \mathbb{I}\{i = 2\}) \right. \\ &\quad \left. + \mathbb{I}\{n = C\} p_i(y, n, m - \mathbb{I}\{i = 1\}) \right) r(y) dy, \quad i \in I. \end{aligned} \quad (2.2)$$

Remark 2.1 *Since the balance equations differ only in their boundary conditions (2.2) there is some evidence for a similar mathematical treatment of the overflow and freed carried traffic. However, Φ_2 is of a semi-Markov structure whereas Φ_1 is a renewal process and hence of a much simpler structure.*

Multiplying (2.1) and (2.2) by $m(m-1) \cdot \dots \cdot (m+1-k)$ and summing over $m \in \mathbb{Z}_+$, for the densities

$$q_{i,k}(x, n) := \sum_{m=0}^{\infty} m \cdot \dots \cdot (m+1-k) p_i(x, n, m), \quad (x, n) \in \mathbb{R}_+ \times \mathbb{X},$$

of the k th partial factorial moments for $i \in I$, $k \in \mathbb{Z}_+$ and $n \in \mathbb{X}$ we obtain the equations

$$\begin{aligned} \frac{d}{dx} q_{i,k}(x, n) &= (n+1)\mu q_{i,k}(x, n+1) - ((n+k)\mu + r(x)) q_{i,k}(x, n), \\ &\quad x > 0, \end{aligned} \quad (2.3)$$

$$\begin{aligned} q_{i,k}(0, n) &= \int_{\mathbb{R}_+} \left(q_{i,k}(y, n-1) + \mathbb{I}\{n = C\} q_{i,k}(y, n) \right. \\ &\quad \left. + (1 - \mathbb{I}\{i = 1, n < C\}) k q_{i,k-1}(y, n - \mathbb{I}\{i = 2\}) \right) r(y) dy. \end{aligned} \quad (2.4)$$

Clearly, $q_{1,0}(x, n) = q_{2,0}(x, n)$, $(x, n) \in \mathbb{R}_+ \times \mathbb{X}$. The system of equations (2.3), (2.4) is equivalent to

$$\frac{d}{dx} Q_{i,k}(x, n) = (n+1)\mu Q_{i,k}(x, n+1) - (n+k)\mu Q_{i,k}(x, n), \quad x > 0, \quad (2.5)$$

$$\begin{aligned}
Q_{i,k}(0, n) &= \int_{\mathbb{R}_+} \left(Q_{i,k}(y, n-1) + \mathbb{I}\{n = C\} Q_{i,k}(y, n) \right. \\
&\quad \left. + (1 - \mathbb{I}\{i = 1, n < C\}) Q_{i,k-1}(y, n - \mathbb{I}\{i = 2\}) \right) dA(y), \tag{2.6}
\end{aligned}$$

where we use the substitution

$$q_{i,k}(x, n) = k!(1 - A(x))Q_{i,k}(x, n) \tag{2.7}$$

and $Q_{i,-1}(x, n) := 0$. Clearly, $Q_{1,0}(x, n) = Q_{2,0}(x, n)$, $(x, n) \in \mathbb{R}_+ \times \mathbb{X}$. The system of equations (2.5), (2.6) is more convenient than (2.3), (2.4) and hence used in the following. Obviously, the system of equations (2.5), (2.6) is well defined for arbitrary $A(x)$. Taking into account that an arbitrary d.f. $A(x)$ can be considered as the limit in distribution of a sequence of distributions $A_\nu(x)$, $\nu \in \mathbb{Z}_+$, with continuous hazard rates, we may apply continuity arguments and consider (2.5), (2.6) and the r.h.s. of (2.7) for arbitrary $A(x)$. Since the succeeding analysis does not use the existence of a hazard rate we may drop this assumption now. For notational convenience we use $A_j^* := A^*(j\mu)$, $j \in \mathbb{Z}_+$, in the following.

Lemma 2.1 *The $Q_{i,k}(x, n)$, $(x, n) \in \mathbb{R}_+ \times \mathbb{X}$, $i \in I$, $k \in \mathbb{Z}_+$, are given by*

$$Q_{i,k}(x, n) = \sum_{j=n}^C \binom{j}{n} \frac{(-1)^{j-n} b_{i,j}^{(k)}}{A_{j+k}^*} \mu e^{-(j+k)\mu x} \tag{2.8}$$

if the coefficients $b_{i,j}^{(k)}$, $i \in I$, $j \in \mathbb{X}$, $k \in \mathbb{Z}_+$, satisfy the system of difference equations

$$\begin{aligned}
&\frac{1 - A_{j+k}^*}{A_{j+k}^*} b_{i,j}^{(k)} - \mathbb{I}\{j > 0\} \left(b_{i,j-1}^{(k)} - \binom{C}{j-1} b_{i,C}^{(k)} \right) \\
&= \mathbb{I}\{i = 1\} \binom{C}{j} b_{i,C}^{(k-1)} + \mathbb{I}\{i = 2\} \left(b_{i,j}^{(k-1)} - \binom{C}{j} b_{i,C}^{(k-1)} + \mathbb{I}\{j > 0\} \right. \\
&\quad \left. \left(b_{i,j-1}^{(k-1)} - \binom{C}{j-1} b_{i,C}^{(k-1)} \right) \right), \quad i \in I, j \in \mathbb{X}, k \in \mathbb{Z}_+, \tag{2.9}
\end{aligned}$$

$$b_{i,0}^{(0)} = 1/(\mu EA), \quad i \in I, \tag{2.10}$$

where $b_{i,j}^{(-1)} := 0$, $i \in I$, $j \in \mathbb{X}$, by convention.

Proof. Denote by $\tilde{Q}_{i,k}(x, n)$ the r.h.s. of (2.8) for arbitrary $b_{i,j}^{(k)} \in \mathbb{R}$. In view of

$$\begin{aligned} & \frac{d}{dx} \tilde{Q}_{i,k}(x, n) - (n+1)\mu\tilde{Q}_{i,k}(x, n+1) + (n+k)\mu\tilde{Q}_{i,k}(x, n) \\ &= \sum_{j=0}^C \left(-(j+k) + (j-n) + (n+k) \right) \binom{j}{n} \frac{(-1)^{j-n} b_{i,j}^{(k)}}{A_{j+k}^*} \mu^2 e^{-(j+k)\mu x} \equiv 0 \end{aligned}$$

the functions $\tilde{Q}_{i,k}(x, n)$ satisfy (2.5).

In order to satisfy the boundary condition (2.6) we insert $\tilde{Q}_{i,k}(x, n)$ into (2.6). The boundary condition (2.6) is fulfilled if for $i \in I$, $n \in \mathbb{X}$, $k \in \mathbb{Z}_+$

$$\begin{aligned} & \sum_{j=0}^C \binom{j}{n} \frac{(-1)^{j-n} b_{i,j}^{(k)}}{A_{j+k}^*} = -\mathbb{I}\{n > 0\} \sum_{j=0}^C \binom{j}{n-1} (-1)^{j-n} b_{i,j}^{(k)} \\ & \quad + \mathbb{I}\{n = C\} b_{i,C}^{(k)} + \mathbb{I}\{i = 1, n = C\} b_{i,C}^{(k-1)} \\ & \quad - \mathbb{I}\{i = 2, n > 0\} \sum_{j=0}^C \binom{j}{n-1} (-1)^{j-n} b_{i,j}^{(k-1)}. \end{aligned} \quad (2.11)$$

Multiplying (2.11) by $(1+z)^n$, summing over $n \in \mathbb{X}$ and using the binomial formula, after elementary algebra we obtain the equivalent condition that for $i \in I$, $k \in \mathbb{Z}_+$, $z \in \mathbb{C}$

$$\begin{aligned} & \sum_{j=0}^C \frac{b_{i,j}^{(k)}}{A_{j+k}^*} z^j = \sum_{j=0}^C b_{i,j}^{(k)} z^j (1+z) - b_{i,C}^{(k)} z (1+z)^C \\ & \quad + \mathbb{I}\{i = 1\} b_{i,C}^{(k-1)} (1+z)^C \\ & \quad + \mathbb{I}\{i = 2\} \left(\sum_{j=0}^C b_{i,j}^{(k-1)} z^j - b_{i,C}^{(k-1)} (1+z)^C \right) (1+z). \end{aligned}$$

Comparing the coefficients of z^j provides the equivalent linear system of equations (2.9) for the $b_{i,j}^{(k)}$.

In view of (2.7), (2.8) the normalizing conditions

$$\int_{\mathbb{R}_+} \sum_{n=0}^C q_{i,0}(y, n) dy = 1, \quad i \in I,$$

are equivalent to (2.10). □

The following lemma provides the existence and expressions for the $b_{i,j}^{(k)}$, $i \in I$, $j \in \mathbb{X}$, $k \in \mathbb{Z}_+$, in particular explicit formulae for the $b_{1,j}^{(k)}$ and a recursive with respect to $k \in \mathbb{Z}_+$ algorithm for the $b_{2,j}^{(k)}$.

Lemma 2.2 *Let $G_{-1} := \infty$ and*

$$G_k := (\mu EA) \prod_{\ell=1}^k \frac{1 - A_\ell^*}{A_\ell^*}, \quad k \in \mathbb{Z}_+. \quad (2.12)$$

For $j \in \mathbb{X}$, $k \in \mathbb{Z}_+$ let

$$B_{1,j}^{(k)} := \frac{\sum_{n=j}^C \binom{C}{n} G_{n+k}}{\sum_{n=0}^C \binom{C}{n} G_{n+k}} - \frac{\sum_{n=j+1}^C \binom{C}{n} G_{n+k-1}}{\sum_{n=0}^C \binom{C}{n} G_{n+k-1}}. \quad (2.13)$$

For $j \in \mathbb{X}$ let

$$B_{2,j}^{(0)} := B_{1,j}^{(0)}. \quad (2.14)$$

For $j \in \mathbb{X}$, $k \in \mathbb{N}$ let

$$\begin{aligned} B_{2,j}^{(k)} := & B_{2,j}^{(k-1)} - \left(\sum_{n=j}^C \frac{B_{2,n}^{(k-1)}}{A_{n+k}^*} - \frac{B_{2,C}^{(k-1)}}{G_{C+k-1}} \sum_{n=j+1}^C \binom{C}{n} G_{n+k-1} \right) \\ & + \left(\sum_{n=0}^C \frac{B_{2,n}^{(k-1)}}{A_{n+k}^*} - \frac{B_{2,C}^{(k-1)}}{G_{C+k-1}} \sum_{n=0}^C \binom{C}{n} G_{n+k-1} \right) \frac{\sum_{n=j}^C \binom{C}{n} G_{n+k}}{\sum_{n=0}^C \binom{C}{n} G_{n+k}}. \end{aligned} \quad (2.15)$$

Then for

$$b_{i,j}^{(k)} := B_{i,j}^{(k)} / G_{j+k}, \quad i \in I, j \in \mathbb{X}, k \in \mathbb{Z}_+, \quad (2.16)$$

the system of difference equations (2.9) and (2.10) is fulfilled.

Proof. Let $b_{i,j}^{(k)}$ defined by (2.16). In case of $k = 0$ the last fraction in (2.13) vanishes because of $G_{-1} = \infty$. Thus from (2.13) for $k = 0$, $j = 0$ and (2.14) for $j = 0$ it follows

$$B_{i,0}^{(0)} = 1, \quad i \in I, \quad (2.17)$$

hence (2.10) is fulfilled on account of (2.16), (2.12).

In case of $i = 1$ using (2.16), (2.13), (2.12) and handling the cases $k = 0$ or $j = 0$ separately provides (2.9) after elementary algebra. As in case of $k = 0$ the systems of difference equations (2.9) do not differ for $i \in I$, in view of (2.14) thus (2.9) is fulfilled for $i = 2$ and $k = 0$, too. In case of $i = 2$ and $k \in \mathbb{N}$ using (2.16), (2.12), applying (2.15) to the l.h.s. of (2.9) and handling the case $j = 0$ separately, after some elementary algebra we obtain (2.9). \square

Remark 2.2 *Because of (2.12), (1.1) it holds*

$$G_k = k!/M_{(k+1)}, \quad k \in \mathbb{Z}_+. \quad (2.18)$$

On account of $1/A_k^ = G_k/G_{k-1} + 1$, $k \in \mathbb{Z}_+$, thus the $B_{i,j}^{(k)}$ and $b_{i,j}^{(k)}$ are given by the $M_{(\ell)}$, $\ell = 1, 2, \dots, C+k+1$.*

In view of (2.14) and (2.13) Lemma 2.2 provides explicit representations for the $B_{2,j}^{(0)}$, $j \in \mathbb{X}$. In principle, for given $k \in \mathbb{N}$ explicit expressions for the $B_{2,j}^{(k)}$, $j \in \mathbb{X}$, can be derived using the recursion (2.15). The following lemma provides explicit expressions for $k = 1$.

Lemma 2.3 *For $j \in \mathbb{X}$ it holds*

$$\begin{aligned} B_{2,j}^{(1)} &= \frac{\sum_{n=j+1}^C \binom{C}{n} G_n}{\sum_{n=0}^C \binom{C}{n} G_n} - \frac{\sum_{n=j}^C \left(\frac{G_{n+1}}{G_n} + 1 \right) \sum_{\ell=n+1}^C \binom{C}{\ell} G_\ell}{\sum_{n=0}^C \binom{C}{n} G_n} \\ &\quad + \frac{\sum_{n=0}^C \left(\frac{G_{n+1}}{G_n} + 1 \right) \sum_{\ell=n+1}^C \binom{C}{\ell} G_\ell}{\sum_{n=0}^C \binom{C}{n} G_n} \frac{\sum_{n=j}^C \binom{C}{n} G_{n+1}}{\sum_{n=0}^C \binom{C}{n} G_{n+1}}. \end{aligned} \quad (2.19)$$

Proof. From (2.15), (2.14) and (2.13) for $j \in \mathbb{X}$ it follows

$$B_{2,j}^{(1)} = \frac{\sum_{n=j}^C \binom{C}{n} G_n}{\sum_{n=0}^C \binom{C}{n} G_n} - \frac{\sum_{n=j}^C \frac{1}{A_{n+1}^*} \sum_{\ell=n}^C \binom{C}{\ell} G_\ell}{\sum_{n=0}^C \binom{C}{n} G_n} - \sum_{n=j+1}^C \binom{C}{n} G_n$$

$$+ \frac{\sum_{n=0}^C \frac{1}{A_{n+1}^*} \sum_{\ell=n}^C \binom{C}{\ell} G_\ell - \sum_{n=0}^C \binom{C}{n} G_n}{\sum_{n=0}^C \binom{C}{n} G_n} \frac{\sum_{n=j}^C \binom{C}{n} G_{n+1}}{\sum_{n=0}^C \binom{C}{n} G_{n+1}}.$$

Using $1/A_{n+1}^* = G_{n+1}/G_n + 1$ we can continue

$$B_{2,j}^{(1)} = - \frac{\sum_{n=j}^C \binom{C}{n} G_{n+1} + \sum_{n=j}^C \left(\frac{G_{n+1}}{G_n} + 1 \right) \sum_{\ell=n+1}^C \binom{C}{\ell} G_\ell - \sum_{n=j+1}^C \binom{C}{n} G_n}{\sum_{n=0}^C \binom{C}{n} G_n} \\ + \frac{\sum_{n=0}^C \binom{C}{n} G_{n+1} + \sum_{n=0}^C \left(\frac{G_{n+1}}{G_n} + 1 \right) \sum_{\ell=n+1}^C \binom{C}{\ell} G_\ell}{\sum_{n=0}^C \binom{C}{n} G_n} \frac{\sum_{n=j}^C \binom{C}{n} G_{n+1}}{\sum_{n=0}^C \binom{C}{n} G_{n+1}},$$

and simplification yields (2.19). □

The following theorem summarizes these results.

Theorem 2.1 *For the densities $q_{i,k}(x, n)$ of the k th partial factorial moments for $(x, n) \in \mathbb{R}_+ \times \mathbb{X}$, $i \in I$, $k \in \mathbb{Z}_+$ it holds*

$$q_{i,k}(x, n) = k!(1-A(x)) \sum_{j=n}^C \binom{j}{n} (-1)^{j-n} \\ \left(\frac{1}{G_{j+k}} + \frac{1}{G_{j+k-1}} \right) B_{i,j}^{(k)} \mu e^{-(j+k)\mu x}, \quad (2.20)$$

where $G_{-1} = \infty$ and $G_k = k!/M_{(k+1)}$ for $k \in \mathbb{Z}_+$, the $B_{1,j}^{(k)}$ are explicitly given by (2.13) for $k \in \mathbb{Z}_+$, $B_{2,j}^{(0)} = B_{1,j}^{(0)}$, the $B_{2,j}^{(1)}$ are explicitly given by (2.19) and the $B_{2,j}^{(k)}$ are recursively given by (2.15) for $k \in \mathbb{N}$.

3 Factorial moments of the overflow and freed carried traffic

Theorem 2.1 allows to proof the formulae (1.2) and (1.3) as announced in the Introduction. In view of (2.20) for the factorial moments $M_{i,(k)}$, $i \in I$,

$k \in \mathbb{N}$, it follows

$$\begin{aligned}
M_{i,(k)} &= \int_{\mathbb{R}_+} \sum_{n=0}^C q_{i,k}(y, n) \, dy \\
&= k! \left(\frac{1}{G_k} + \frac{1}{G_{k-1}} \right) B_{i,0}^{(k)} \int_{\mathbb{R}_+} (1-A(y)) \mu e^{-k\mu y} \, dy \\
&= (k-1)! (1-A_k^*) \left(\frac{1}{G_k} + \frac{1}{G_{k-1}} \right) B_{i,0}^{(k)}, \tag{3.1}
\end{aligned}$$

and taking into account (2.12) we obtain

$$M_{i,(k)} = (k-1)! B_{i,0}^{(k)} / G_{k-1}, \quad i \in I, \quad k \in \mathbb{N}. \tag{3.2}$$

Formula (1.2) for the factorial overflow moments is now an immediate consequence of Lemma 2.2.

Corollary 3.1 *The $M_{1,(k)}$, $k \in \mathbb{N}$, are given by (1.2).*

Proof. From (3.2) for $i = 1$ and (2.13) we obtain

$$M_{1,(k)} = (k-1)! \left(\sum_{n=0}^C \binom{C}{n} G_{n+k-1} \right)^{-1}, \quad k \in \mathbb{N}. \tag{3.3}$$

Thus (1.2) is proved in view of (2.18). □

Because of (2.15) from (3.2) for $i = 2$ it follows

$$M_{2,(k)} = (k-1)! \left(\frac{B_{2,0}^{(k-1)}}{G_{k-1}} - \frac{B_{2,C}^{(k-1)}}{G_{C+k-1}} \right), \quad k \in \mathbb{N}. \tag{3.4}$$

The offered with respect to k recursive algorithm (2.15) for computing the $B_{2,j}^{(k)}$, $j \in \mathbb{X}$, allows, in principle, to derive via (3.4) an explicit formula for $M_{2,(k)}$ for given $k \in \mathbb{N}$. However, for practical purposes, cf. the Introduction, we are mainly interested in the peakedness $Z_2 = 1 - M_{2,(1)} + M_{2,(2)}/M_{2,(1)}$, i.e. in $M_{2,(2)}$. (Note that $M_{2,(1)} = M_{(1)} - M_{1,(1)}$.)

Theorem 3.1 *The factorial moment $M_{2,(2)}$ is given by (1.3).*

Proof. From (2.19), (2.18) and (3.3) it follows

$$\frac{B_{2,0}^{(1)}}{G_1} = \frac{1}{G_1} \frac{\sum_{n=1}^C \binom{C}{n} G_n}{\sum_{n=0}^C \binom{C}{n} G_n} = \frac{1}{G_1} \left(1 - \frac{G_0}{\sum_{n=0}^C \binom{C}{n} G_n} \right) = M_{(2)} \left(1 - \frac{M_{1,(1)}}{M_{(1)}} \right),$$

and applying $M_{1,(1)} = M_{(1)} - M_{2,(1)}$ provides

$$\frac{B_{2,0}^{(1)}}{G_1} = M_{2,(1)} \frac{M_{(2)}}{M_{(1)}}. \quad (3.5)$$

Moreover, from (2.19) it follows

$$\begin{aligned} \frac{B_{2,C}^{(1)}}{G_{C+1}} &= \frac{\sum_{n=0}^C \left(\frac{G_{n+1}}{G_n} + 1 \right) \sum_{\ell=n+1}^C \binom{C}{\ell} G_\ell}{\left(\sum_{n=0}^C \binom{C}{n} G_n \right) \left(\sum_{n=0}^C \binom{C}{n} G_{n+1} \right)} \\ &= \frac{\sum_{\ell=1}^C \binom{C}{\ell} G_\ell \sum_{m=1}^{\ell} \left(\frac{G_m}{G_{m-1}} + 1 \right)}{\left(\sum_{n=0}^C \binom{C}{n} G_n \right) \left(\sum_{n=0}^C \binom{C}{n} G_{n+1} \right)}. \end{aligned}$$

Thus (2.18) and (3.3) yield

$$\frac{B_{2,C}^{(1)}}{G_{C+1}} = M_{1,(1)} M_{1,(2)} \sum_{\ell=1}^C \binom{C}{\ell} \frac{\ell!}{M_{(\ell+1)}} \sum_{m=1}^{\ell} \left(\frac{m M_{(m)}}{M_{(m+1)}} + 1 \right). \quad (3.6)$$

Finally, from (3.4) for $k = 2$, (3.5) and (3.6) we obtain (1.3). □

Remark 3.1 *The numerical algorithms in [HH] for computing Z_2 base on the fact that the freed carried traffic can be characterized as a semi-Markov process and that there are relations between the occupancy distribution in the time stationary and event stationary dynamics. By deriving first explicit formulae for the semi-Markov process characteristics, a linear system of C equations for conditional first moments of the freed carried traffic is obtained, which has to be solved numerically. A straightforward implementation of the algorithms poses numerical problems for $C \geq 10$. Thus modifications are discussed for obtaining more stable algorithms in the IPP case,*

cf. [HH] pp. 1638–1642. The idea is to compute the stationary distribution in the primary group at the call arrivals via birth-death equations and to improve the computation of the coefficients of the mentioned linear system of equations for this special case. These modifications extend the useful range of C , examples up to $C=100$ are reported.

For a Poisson process of intensity λ Eq. (1.1) reduces to $M_{(k)} = M^k$, where $M = \lambda/\mu$. After some algebra from (1.2) and (1.3) we obtain

$$M_1 = MB(M, C), \quad M_2 = M - M_1, \quad (3.7)$$

$$Z_1 = 1 - M_1 + \frac{M}{C+1-M_2}, \quad (3.8)$$

$$Z_2 = 1 - \frac{M_1}{2M_2} (C+1-M_2-Z_1), \quad (3.9)$$

where B denotes the Erlang loss function. Note, that (3.7), (3.8) are well known, cf. e.g. [Gira], [Pott], whereas (3.9) seems to be new.

4 Application and numerical results

Without loss of generality in the following we assume $\mu = 1$. IPP's are GI -streams with a H_2 interarrival time distribution

$$A(t) = r(1 - \exp(-\alpha_1 t)) + (1-r)(1 - \exp(-\alpha_2 t)), \quad t \in \mathbb{R}_+, \quad (4.1)$$

with parameters $r \in [0, 1]$, $\alpha_1 > 0$, $\alpha_2 > 0$. For the special case (4.1) from (1.1) it follows

$$M_{(k)} = \prod_{j=0}^{k-1} \frac{\alpha_1 \alpha_2 + (r\alpha_1 + (1-r)\alpha_2)j}{r\alpha_2 + (1-r)\alpha_1 + j}, \quad k \in \mathbb{N}. \quad (4.2)$$

Thus for the mean M and peakedness Z of an IPP we obtain

$$M = \frac{\alpha_1 \alpha_2}{r\alpha_2 + (1-r)\alpha_1}, \quad (4.3)$$

$$Z = 1 + \frac{r(1-r)(\alpha_1 - \alpha_2)^2}{(r\alpha_2 + (1-r)\alpha_1)(r\alpha_2 + (1-r)\alpha_1 + 1)}. \quad (4.4)$$

As overflow streams are often approximated by IPP's in practice, cf. [Kucz], [Rene], we choose an IPP as the arriving GI -stream Φ in case of $Z \geq 1$.

For a given mean $M > 0$ and peakedness $Z \geq 1$ we determine the IPP parameters by Rapp's approximation, cf. [Rapp], [Gira], [Kucz]:

$$\begin{aligned}\lambda &:= MZ + 3Z(Z-1), & \omega &:= \frac{M}{\lambda} \left(M + 3Z - 1 \right), & \gamma &:= \omega \left(\frac{\lambda}{M} - 1 \right), \\ \alpha_{1/2} &:= \frac{1}{2} \left((\lambda + \omega + \gamma) \pm \sqrt{(\lambda + \omega + \gamma)^2 - 4\lambda\omega} \right), & r &:= \frac{\lambda - \alpha_2}{\alpha_1 - \alpha_2}.\end{aligned}\quad (4.5)$$

In case of $Z < 1$ we choose an GI -stream with interarrival time distribution

$$A(t) = r(1 - \exp(-\alpha t)) + (1-r)\mathbb{I}\{t \geq 1/\alpha\}, \quad t \in \mathbb{R}_+, \quad (4.6)$$

with parameters $r \in [0, 1)$ and $\alpha > 0$, being a mixture of an exponentially distributed r.v. and a constant time with balanced means, as the arriving GI -stream Φ . From (1.1) it follows

$$M_{(k)} = \alpha \prod_{j=1}^{k-1} \frac{j(r\alpha + (1-r)(\alpha + j) \exp(-j/\alpha))}{(\alpha + j) - (r\alpha + (1-r)(\alpha + j) \exp(-j/\alpha))}, \quad k \in \mathbb{N}. \quad (4.7)$$

Thus for the mean M and peakedness Z we obtain

$$M = \alpha, \quad Z = \frac{\alpha + 1}{r + (1-r)(\alpha + 1)(1 - \exp(-1/\alpha))} - \alpha. \quad (4.8)$$

For a given mean $M > 0$ and peakedness $Z \in [Z_{\min}(M), 1)$ we find $\alpha = M$ and a uniquely determined $r \in [0, 1)$ such that (4.8) holds.

Remark 4.1 (1) For a numerically stable calculation of the factorial moments (4.7) we recommend the following recursion with respect to $k \in \mathbb{N}$:

$$C_0 := 0, \quad M_{(1)} := \alpha, \quad q := \exp(-1/\alpha),$$

$$C_k := C_{k-1} + \frac{r\alpha + (1-r)(1-q)(\alpha + k - 1)(\alpha + k)q^{k-1}}{(r\alpha + (1-r)(\alpha + k - 1)q^{k-1})(r\alpha + (1-r)(\alpha + k)q^k)},$$

$$M_{(k+1)} := kM_{(k)}/C_k.$$

Note, that $C_k = 1/A_k^* - 1$ for $k \in \mathbb{Z}_+$.

(2) The peakedness $Z_{\min}(M)$ is achieved by constant interarrival times, cf. [FK], [v.Do]. Also using hyper-exponential traffic, cf. [v.Do] p.101, or gamma-distributed $A(t)$, traffic streams with peakedness $Z \in (Z_{\min}(M), 1)$ can be fitted. However, the calculation of the factorial moments $M_{(k)}$ for $k \in \{1, \dots, C+2\}$ is of higher complexity.

The described algorithms for computing the means and peakedness factors of the overflow and of the freed carried traffic are of complexity $\mathcal{O}(C)$. They have been implemented in a C++ program. This program allows the computation of the means and peakedness factors of the overflow and of the freed carried traffic as well as the computation of the time congestion, cf. [GK] p.26, for a given mean and peakedness of the arrival stream and a given capacity of the link.

Table 4.1: *Link of capacity C , where a traffic stream with mean M and peakedness Z arrives. M_1, Z_1, Z_2 denote the mean and peakedness of the overflow traffic and the peakedness of the freed carried traffic in case of $Z = 0.8$, respectively; M'_1, Z'_1, Z'_2 denote the mean and peakedness of the overflow traffic and the peakedness of the freed carried traffic in case of $Z = 8.0$, respectively.*

M	C	M_1	Z_1	Z_2	M'_1	Z'_1	Z'_2
60	64	3.01	3.83	0.77	13.44	14.61	3.35
64	64	5.34	3.69	0.79	16.02	14.61	3.07
68	64	8.17	3.44	0.82	18.77	14.56	2.82
248	256	6.43	7.28	0.77	28.90	24.93	3.55
256	256	11.04	6.93	0.79	33.95	24.68	3.27
264	256	16.64	6.39	0.82	39.32	24.35	3.01
1008	1024	13.28	14.19	0.77	60.02	45.95	3.63
1024	1024	22.45	13.44	0.79	70.00	45.20	3.34
1040	1024	33.58	12.31	0.82	80.60	44.32	3.09
4064	4096	27.00	28.03	0.77	122.33	88.13	3.66
4096	4096	45.28	26.47	0.79	142.18	86.39	3.38
4128	4096	67.48	24.16	0.82	163.27	84.40	3.12
16320	16384	54.43	55.72	0.77	247.02	172.54	3.67
16384	16384	90.95	52.54	0.79	286.60	168.81	3.39
16448	16384	135.29	47.86	0.82	328.66	164.62	3.14

Table 4.1 has been drawn up using this program. It can be seen that the mean of the overflow traffic and the peakedness factors of the overflow and of the freed carried traffic strongly depend on the peakedness of the arrival stream.

References

- [BFL] Brandt, A., Franken, P., Lisek, B., *Stationary Stochastic Models*. Akademie-Verlag, Berlin; Wiley, Chichester, 1990.
- [Desc] Deschamps, P.J., Analytic approximation of blocking probabilities in circuit switched communication networks. IEEE Trans. on Comm., vol. COM-27, No. 3 (1979) 603–606.
- [FK] Franken, P., Kerstan, J., Bedienungssysteme mit unendlich vielen Bedienungssystemen. in: *Operationsforschung und mathematische Statistik I*. Akademie-Verlag, Berlin, 1968, 67–76.
- [FKAS] Franken, P., König, D., Arndt, U., Schmidt, V., *Queues and Point Processes*. Akademie-Verlag, Berlin; Wiley, Chichester, 1982.
- [Gira] Girard, A., *Routing and Dimensioning in Circuit-Switched Networks*. Addison-Wesley, Reading, 1990.
- [GK] Gnedenko, B.W., König, D., *Handbuch der Bedienungstheorie. Vol. I, Vol. II*. Akademie-Verlag, Berlin, 1984.
- [HH] Heffes, H., Holtzman, J.M., Peakedness of traffic carried by a finite trunk group with renewal input. Bell Sys. Tech. J. 52 (1973) 1617–1642.
- [Katz] Katz, S., Statistical performance analysis of switched communications networks. Proc. 5th Int. Teletraffic Cong., (1967) 566–575.
- [Kucz] Kuczura, A., The interrupted Poisson process as an overflow process. Bell Sys. Tech. J. 52, No. 3 (1973) 437–448.
- [KB] Kuczura, A., Bajaj, D., A method of moments for the analysis of a switched communication network's performance. IEEE Trans. on Comm., vol. COM-25, No. 2 (1977) 185–193.
- [PP] Pearce, C., Potter, R., Some formulae old and new for overflow traffic in telephony. Australian Telecommunication Research 11 (1977) 92–97.
- [Pott] Potter, R.M., Explicit formulae for all overflow moments of the Kosten and Brockmeyer systems with renewal input. Australian Telecommunication Research 13 (1980) 39–49.

- [Rapp] Rapp, Y., Planning of junction network in a multiexchange area. Ericsson Technics 20, No. 1 (1964) 77–130.
- [Rene] Reneby, L., Service protection and overflow in circuit switched networks. Thesis, Technical Report 107, Department of Communication Systems 1991.
- [Tak1] Takacs, L., On the generalization of Erlang’s formula. Acta Math. Acad. Sci. Hungar. 7 (1956) 419–433.
- [Tak2] Takacs, L., On the limiting distribution of the number of coincidences concerning telephone traffic. Ann. Math. Statist. 30 (1959) 134–142.
- [Tak3] Takacs, L., *Introduction to the Theory of Queues*. Oxford University Press, New York, 1962.
- [v.Do] van Doorn, E.A., Some analytical aspects of the peakedness concept. Proc. 10th Int. Teletraffic Cong., Montreal 1983.
Extended version: Some aspects of the peakedness concept in teletraffic theory. J. of Inf. Processing and Cybernetics (Elektron. Inf. verarb. Kybern.) EIK 22, No. 2/3 (1986) 93–104.
- [Wall] Wallstrøm, B., Congestion studies in telephone systems with overflow facilities. Ericson Technics, No. 3 (1966) 190–351.
- [Wilk] Wilkinson, R.I., Theories for toll traffic engineering in the U.S.A. Bell Sys. Tech. J. 35, No. 2 (1956) 421–514.
- [E.524] The International Telegraph and Telephone Consultative Committee (CCITT), Recommendation E.524. Geneva 1992.