

**SUPPLY CHAIN COMPLEXITY:
A CASE STUDY IN THE DRIVE AND CONTROL
INDUSTRY**

SILKE MALINA

Dissertation for obtaining the degree of Doctor of Business and Economics

(Doctor rerum politicarum - Dr. rer. pol.) at

WHU-Otto Beisheim School of Management

Vallendar, Germany

09 October 2019

First Advisor:

Prof. Dr. Stefan Spinler

Second Advisor:

Prof. Dr. Carl Marcus Wallenburg

Silke Malina: *Supply Chain Complexity: A case study in the drive and control industry,*

©

09 October 2019

ABSTRACT

Supply chain management (SCM) is known as a competitive strategy in today's business. Through increasing product variety, structures and processes, managers struggle with an increase in supply chain complexity (SCC), which leads to a negative influence on a firm's efficiency in terms of lead times, flexibility and costs. In order to manage complexity, supply chain managers need to know its drivers or define appropriate management measures. However, managers can no longer manage SCC internally. In order to cope with this challenging issue and achieve overall benefits, it is necessary that the complete supply chain is involved in optimising supply chain processes. An aligned supply chain should ensure that supply chain partners benefit from cost savings. At the same time, supply chain processes should be agile to respond to market volatility, while also being cost-efficient to survive in the highly competitive world.

In this dissertation, three research cases are conducted with different focus areas, whereby first drivers for internal and external SCC are explored in a single case study. In order to gain a representative overview of relevant drivers, not only interviews with top managers from a manufacturer are held but also with key managers from suppliers and customers. With the interviews held from the upstream to downstream supply chain, this part of the dissertation sheds light on topical SCC drivers and provides some hypotheses for managing detailed and dynamic SCC. With this case, an academic contribution is provided to better understand the relevance of SCC.

In a second step, another qualitative study addresses the requirements of a supply chain. The basis for this part is the triple-A supply chain of Hau Lee (2004), where he states from a theoretical perspective the prerequisites of a supply chain, namely agility, adaptability and alignment. In this dissertation, this approach is reviewed from a managerial perspective. It is analysed which key performance indicators of a firm are affected by the three aforementioned qualities. Finally, it is presented how agility, adaptability and alignment are linked together. In order to gain a common understanding, semi-structured interviews are conducted to extend literature through managerial experience.

In a third step, a quantitative simulation creating a discrete-event simulation model is provided to evaluate inventory and logistics costs' effects in a company that faces significant SCC. The target is to align the supply chain by changing the existing distribution channel to direct delivery. The result shall demonstrate the financial benefit for the supply chain partners, as well as illustrating the conditions and risks when changing supply chain processes.

This dissertation shows that companies are increasingly faced by SCC. In order to respond flexibly to market volatility, supply chains must be agile to ensure that financial risk shall not alarm a company's existence. Therefore, it is recommended to align the supply chain with a collaborative supply chain model.

ACKNOWLEDGEMENTS

I am grateful to my primary advisor Prof. Dr. Stefan Spinler as well as my second advisor Prof. Dr. Carl Marcus Wallenburg from WHU-Otto Beisheim School of Management for their support in this doctoral research. Special thanks go to Prof. Dr. Stefan Spinler, whose expertise, understanding and generous guidance and support made it possible for me to work on a topic that held strong interest to me. It was a pleasure working with him. Furthermore, he has been very constructive in all activities to seek further feedback from fellow researchers and practitioners at conferences or seminars. Moreover, I would like to thank Prof. Dr. Wallenburg for his helpful comments and suggestions, as well as his openness.

I would like to thank the company that enabled the case study and all interviewees for supporting this dissertation and providing relevant information for the completion of this dissertation.

A special thanks goes to my family. Words cannot express how grateful I am to my beloved husband Kolos and my beloved children Kilian and Sophia, as well as to my parents for all of the sacrifices that you have made on my behalf.

CONTENTS

1	INTRODUCTION.....	15
1.1	Supply Chain Complexity.....	18
1.2	Supply Chain Agility.....	19
1.3	Discrete Event Simulation for Supply Chain Alignment.....	20
2	DRIVERS OF SUPPLY CHAIN COMPLEXTIY: A LITERATURE REVIEW AND A CASE STUDY IN THE DRIVE AND CONTROL INDUSTRY.....	22
2.1	Introduction.....	22
2.2	Literature Review.....	24
2.2.1	Background and Definition of Complexity.....	24
2.2.2	Supply Chain Complexity.....	25
2.2.3	Types of Supply Chain Complexity.....	27
2.2.4	The role of Product Complexity	29
2.2.5	Strategies of Supply Chain Complexity.....	31
2.2.6	Research Objectives.....	35
2.3	Methodology.....	37
2.3.1	Data Collection Methodology.....	37
2.3.2	Sample Description.....	38
2.3.3	Data Analysis.....	42
2.4	Findings.....	43
2.4.1	Review of Supply Chain Complexity Drivers.....	43
2.4.2	The Role of Product Variety on Supply Chain Complexity.....	49

2.4.3	The Role of Performance Indicators for Supply Chain Complexity.....	53
2.5	Implications for the Management of Supply Chain Complexity.....	55
2.6	Conclusion.....	61
3	SUPPLY CHAIN AGILITY: A CASE STUDY IN THE DRIVE AND CONTROL INDUSTRY.....	65
3.1	Introduction.....	65
3.2	Literature Review.....	67
3.2.1	Supply Chain Agility.....	67
3.2.2	Supply Chain Adaptability.....	69
3.2.3	Supply Chain Alignment.....	70
3.2.4	Research Motivation.....	71
3.3	Research Methodology.....	73
3.3.1	Case Study Methodology.....	73
3.3.2	Sample Description.....	74
3.3.3	Data Collection and Analysis.....	75
3.4	Findings.....	77
3.4.1	Design of Performance Indicators.....	77
3.4.2	Interdependence of SCAg, SCAd and SCAl.....	81
3.4.3	Optimal Levels of Supply Chain Agility, Adaptability and Alignment.....	86
3.5	Summary of Case Study Findings.....	91
3.6	Conclusion.....	94

4	REDUCTION OF SUPPLY CHAIN COMPLEXITY BY REDESIGNING THE SUPPLY CHAIN: A DISCRETE-EVENT SIMULATION IN THE MACHINE CONSTRUCTION INDUSTRY.....	97
4.1	Introduction.....	98
4.2	Literature Review.....	99
4.2.1	Background Discrete-Event Simulation.....	99
4.2.2	Application of Discrete-Event Simulation.....	101
4.2.3	The Role of Supply Chain Complexity.....	102
4.2.4	Research Motivation.....	103
4.3	Supply Chain Redesign.....	105
4.3.1	Supply Chain Design from the Perspective of an OEM.....	105
4.3.2	Case Study: Status quo of Supply Chain.....	106
4.3.3	Future Simulation Concept.....	111
4.3.4	Simulation with ExtendSim®.....	113
4.3.5	Relevant Costs for the Simulation.....	118
4.3.6	Relevant System Parameters.....	121
4.4	Scenario Analysis.....	126
4.4.1	Comparison Status quo vs. Simulation.....	126
4.4.2	Model Verification.....	129
4.5	Findings and Managerial Implication.....	133
4.6	Conclusion.....	134

5	SUMMARY AND OUTLOOK.....	137
5.1	Summary.....	137
5.2	Outlook.....	139
A	APPENDIX TO CHAPTER 2.....	141
B	APPENDIX TO CHAPTER 3.....	152
C	APPENDIX TO CHAPTER 4.....	159
	BIBLIOGRAPHY.....	160

LIST OF FIGURES

Figure 1.1	Global machinery production revenue forecast and annual growth rates.....	16
Figure 2.1	Supply chain of the manufacturer.....	41
Figure 2.2	Development of number of suppliers and logistics cost for controlling unit.....	49
Figure 2.3	Variant analysis of controlling unit.....	51
Figure 3.1	Framework of a Triple A supply chain.....	84
Figure 3.2	Vertical and horizontal supply chain alignment.....	89
Figure 4.1	Diagram of information and material flow; base situation of resale process.....	108
Figure 4.2	Development of inventories and logistics costs.....	109
Figure 4.3	Distribution of logistics costs per type in %.....	110
Figure 4.4	Flow diagram of information and material flow; simulated direct delivery process.....	112
Figure 4.5	Main screen of the simulation model.....	115

LIST OF TABLES

Table 2.1	Definitions of complexity in SCM.....	26
Table 2.2	Case description.....	39
Table 2.3	Participants of interviews.....	40
Table 2.4	Identified drivers of SCC and measuring KPIs.....	47
Table 3.1	Overview of interviewees.....	76
Table 3.2	Overview of KPI assignment for SCAG, SCAd and SCAl.....	80
Table 4.1	Overview of relevant types of costs.....	120
Table 4.2	Overview of variables and mathematical equations.....	120
Table 4.3	Average inventory per product (in TEUR).....	126
Table 4.4	Average logistics costs (in TEUR).....	128
Table 4.5	Calibration scheme of the DES model.....	129
Table 4.6	Development of logistics costs in case of growing market.....	131
Table 4.7	Development of logistics costs in case of shrinking market.....	132

ACRONYMS AND ABBREVIATIONS

AP	Asia Pacific
CAGR	compound annual growth rate
CEO	chief executive officer
CIP	continuous improvement process
DES	discrete event simulation
EU	Europe
FIFO	first-in-first-out
KPI	key performance indicator
NA	North America
OM	operations management
R&D	research and development
SC	supply chain
SCAd	supply chain adaptability
SCAg	supply chain agility
SCAl	supply chain alignment
SCC	supply chain complexity
SCM	supply chain management
SD	system dynamics
SDD	semi-direct delivery
IT	information technology
UK	United Kingdom

1 INTRODUCTION

Global supply chains are seen as a source of competitive advantage. Cheap workforce and raw materials, attractive finance opportunities as well as growing product markets and other incentives offered by host governments attract foreign capital (Kogut and Kulatilaka, 2001). However, coupled with these benefits that attract firms to go global, firms are faced with increased SCC in global supply chains, whereby companies are forced to look for more effective ways to coordinate the flow of information and material in and out of the company (Mentzer et al., 2001). There is wide acknowledgement in literature about SCC as a risk factor in multinational companies (Baird and Thomas, 1985; Baird and Thomas, 1991; Ghoshal, 1987; Kogut, 1985; Lessard and Lightstone, 1986; Miller, 1992). Special research on SCC as part of risk management has expanded literature on this topic (Zsidisin et al., 2004; Christopher, 2004; Giunipero et al., 2004; Juettner, 2005; Manuj et al., 2008; Norrman et al., 2004; Spekman et al., 2004; Zsidisin, 2003). Chopra and Sodhi (2004) argue that most firms develop plans to protect against periodic low-impact risks in their supply chains. Such risks occur through globalisation and its associated increased SCC. By understanding the variety and linking-up of SCC, managers can design balanced, effective supply chain strategies for their companies. Hauser (2003) suggests that in today's increasingly complex environment, adjusted SCM can lead to improved financial performance and competitive advantage. In sum, understanding global SCC is important and a top priority for both academics and practitioners.

In order to extend literature about the phenomenon of SCC, the research of this dissertation is executed in the machine construction industry. The machine construction industry plays quite an important role in regions like America, Europe and countries like China and Japan. The focus of the research in this dissertation is case studies with companies in this industry. In recent years, the machine construction industry has been heavily faced by strong dynamic market volatility as well as financial cycles that are becoming increasingly shorter. In some ways, the machine construction industry is *the knot at the end of the whip of the economy* (IHS, 2014). The industry reflects many of the same cyclical characteristics of the economy in general, although ultimately the operational challenges for companies are greater, the speed is faster and the effects more distinctive. Just as manufacturing slowdowns often allow perceiving economic

downturns, the machine construction industry leads the manufacturing sector in periods of contraction. However, whereas the manufacturing sector often leads the economy into recovery, the production in the machine construction industry lags during the beginning of a recovery. The normal cycle of the economy is thus compressed for the machine construction industry, whereby peaks are shorter and troughs are longer. Almost the first thing that manufacturers do when they believe that a contraction is occurring is to stop the purchase of capital goods. Manufacturers want to be certain that a recovery is arriving before they think of making investments in capital goods, so they are much more likely to wait until the recovery is solidly established before they order capital equipment again (IHS, 2014).

Fig.1.1: Global machinery production revenue forecast and annual growth rates (revenue in trillions of US dollars)

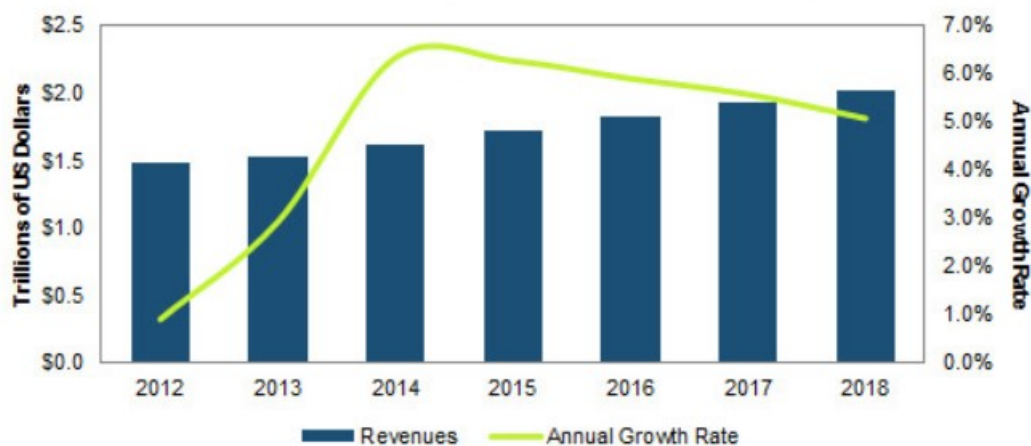

Source: IHS, April 2014

As economic conditions continue to improve worldwide, the demand for machines in sectors such as agriculture, packaging, materials handling and machine tools pushed revenues to \$1.6 trillion in 2014, up from \$1.5 trillion in 2013 (Fig.1.1). This represents an annual growth of 6.3 percent, more than twice the 2.9 percent increase seen in 2013. Growth is forecasted to continue for the next years, with revenue rising to \$2.0 trillion by 2018. During this period, the machinery market’s annual growth rate will remain quite impressive, averaging between 5 and 6 percent. “The improving economic outlook is a key factor in the strong growth of machinery in the coming years,” said Andrew Robertson, senior analyst for industrial automation at IHS. “The growing populations

and the expanding middle classes in developing countries are generating more disposable income. This translates into increased demand across a vast number of sectors.” In recent years the machinery market in China has experienced considerable overcapacity, specifically in the construction machinery, machine tools and metal working sectors. Machinery production revenue slowed to 1.8 percent growth in 2012, marking a huge dip from the 20 percent growth average from a decade before. As a result, only a few businesses experienced growth, while weak investment in 2013 caused many heavy industries to struggle.

The growth of the machinery market represented a welcome change in 2012, when not every region performed well. The Americas prospered in 2012, boosted by a significant government investment that caused machinery production revenue to grow by 6.5 percent. In 2013, machinery production growth in the Americas slowed to 2.0 percent, although it still fared better than some of the other regions. For instance, in the Asia-Pacific region, growth slowed to only 3.5 percent. The majority of this slowdown came from China, where production remained nearly flat due to overcapacity. Meanwhile, Europe struggled as a result of the economic problems persisting throughout the region, and machinery production revenue declined by 5.6 percent in 2012, dragging down the entire global market. Europe increased output last year, albeit only by 1.1 percent (IHS, 2014).

A review of literature on SCC in dynamic markets led to identifying the gap that more research is needed regarding existing drivers of SCC in the machine construction industry. A qualitative research design is chosen, as not much is known about the phenomenon along the upstream and downstream supply chain. Additionally, the dissertation explores the qualities of a global supply chain. As markets change more rapidly, academics and practitioners need to know what these changes mean for the supply chain design. Finally, the research outcomes are simulated. Expanding the theory to other contexts like other industries is left to future research.

This dissertation provides three major contributions. First, drivers for SCC in the machine construction industry are explored. In addition, a differentiation between internal and external complexity drivers is conducted. Second, the requirements or qualities of a global supply chain are discussed. As market volatility becomes more dynamic, companies are forced to align their global supply chains accordingly to control

and improve their financial performance. Third, a discrete-event simulation model is applied to analyse the effect of defined SCC drivers in an agile supply chain.

1.1 Supply Chain Complexity (SCC)

The last twenty years have seen a steady convergence of the traditionally-distinct areas of operations management (OM), sourcing and logistics into a single area commonly known as supply chain management (SCM). According to the SCM perspective, it is no longer adequate for businesses to run these areas as individual units of excellence; rather, they must also develop and manage the information flows, physical flows and relationships that link these areas together, as well as linking these areas with upstream and downstream partners. At the same time, the SCM perspective requires businesses to broaden the scope of business activities that must be designed and managed, and the nature of these activities has become more challenging as product life cycles shorten, product variety and customisation levels increase and supply chain partners become more geographically dispersed. Therefore, managing the supply chain is clearly a challenging mission, and most observers would agree that a supply chain is a complicated system. However, in this dissertation, the concepts and terminology of the systems science literature are used to formally define SCC, clarifying the aspects of supply chains that make them truly complex systems. While strong attention has been paid to why it is necessary for companies to expand the scope and depth of their supply chain activities (Swafford et al., 2006), only recently have researchers and practitioners begun to consider the downside of this added complexity (Hoole, 2006). In addition to defining SCC, the impact of various sources of complexity is empirically explored: upstream in the supply chain involving suppliers, internal to the manufacturing plant, and downstream from the plant to the customer. The results allow identifying sources and different types of complexity that have a significant impact on a firm's process and organisation. These results may be valid for different industries and geographic regions of the globe. Moreover, the results confirm existing lean production literature in terms of the importance of certain sources of complexity in explaining poor manufacturing performance. The research also helps to provide important priorities for supply chain managers for their decision-making.

1.2 Supply Chain Agility

Supply chain management (SCM) helps firms in integrating their business by collaborating with other value chain partners to meet the unpredictable demand of the end user. An integrated supply chain or seamless supply engineered to cope with volatile can profitably satisfy customer demand, while non-integrated manufacturing processes, non-integrated distribution processes and poor relationships with suppliers and customers are the judgement of business failure for firms. Providing time-based competition, supply chains must have the ability to meet the demands of customers for ever-shorter delivery times and synchronise supply during the peaks and troughs of the demand. For this purpose, supply chains must be responsive to the needs of the market. Responsiveness requires speed and a high level of manoeuvrability, which is also termed as agility (Christopher, 2000).

Agility is business-wide the capability that embraces organisational structures, information systems and in particular mind sets (Christopher, 2000). Agility means using market knowledge and virtual corporation to exploit profitable opportunities in a volatile marketplace (Mason-Jones & Towill, 1999). Christopher (2000) has identified a number of characteristics that a supply chain must have to be “truly agile”:

- 1.) Market-sensitive – end user trends are considered.
- 2.) Virtual – information is shared across all supply chain partners.
- 3.) Network-based – flexibility is ensured by using the strengths of specialist players.
- 4.) Process integration – high degree of process interconnectivity between the network members.

In the literature, frameworks based on other characteristics of supply chain agility have also been suggested. For example, Bal, Wilding, and Goundry (1999) have proposed virtual teaming model for introducing agility in a supply chain. Yusuf, Sarhadi, and Gunasekaran (1999) have presented a conceptual model for designing an agile manufacturing system based on the four key dimensions of strategies, technology, people, and system. Meade and Sarkis (1999) have used four dimensions to measure the

agility of a manufacturing system, namely cooperating to enhance competitiveness, enriching customer, mastering change and uncertainty, as well as leveraging the impact of people and information.

Tolone (2000) has supported the role of real-time and asynchronous collaboration technology in allowing manufacturers to increase their supply chain agility. Prater, Biehl, and Smith (2001) have used case studies to show how firms have successfully made a trade-off between vulnerability and supply chain agility.

Literature on supply chain agility describes the dependence of agility on the characteristics of some performance variables, although the influence of interrelationships among the variables on the supply chain agility has been hardly taken into account in the literature. Further research is also needed for supply chain adaptability and supply chain alignment, given that research currently remains in its infancy.

Therefore, there is a need to identify variables influencing supply chain agility and develop generally an applicable framework that establishes interrelationships. This research expands Lee's (2004) work on the so-called triple-A supply chain. Lee describes an effective and successful supply chain by considering supply chain agility, supply chain adaptability and supply chain alignment. These qualities are explored from a managerial perspective as well as their relation to key performance indicators.

1.3 Discrete-Event Simulation for Supply Chain Alignment

In supply chain management, typical tools like system dynamics, optimisation and simulation are used for analysis. Either historical data or new data is collected to create theoretical models and observe the supply chain behaviour. Experiments are helpful to explore causal effects and test different scenarios. However, causal effects are difficult to identify if they are separated in space and time (Persson et al., 2009). A different way to conduct experiments in a current system is to apply a model of the system for further experiments. Many models in literature involve supply chain optimisation and answer questions regarding plant location, choice of technology, means of distribution, product

mix or inventory management (Goetschlkcx et al., 2002, Shapiro, 2001, Fandel et al., 2004).

Optimisation and simulation differentiate in their methodological and practical approach in terms of how to find solutions. With optimisation, the result depends on the scenario that defines the experimental environment. The optimal result is only valid for the explicit scenario and it will become invalid if the scenario changes (Zeigler et al., 2000). In simulation, a set of scenarios can be tested to find an optimal solution. Therefore, the approach from simulation can be used more intensely with environmental changes than the approach from optimisation for an optimal solution. As simulation is more suitable for demonstrating random effects which are included in simulation-based optimisation and forecasting the dynamic behaviour of supply chains, simulation can be used as a supplement for modelling using optimisation models (Persson et al., 2009).

The two widely-used modelling tools which sustain decision support systems are discrete-event simulation (DES) and system dynamics (SD) (Tako et al., 2012). Simulation-based decision support systems offer solutions to questions of both strategic and operational level in the field of logistics and SCM. Specific examples include supply chain design and reconfiguration, inventory management and control, production scheduling and supplier selection. Even if DES and SD are widely used in logistics and SCM, the specific use as a decision support system is not well understood (Tako et al., 2012).

In this dissertation, the approach of DES and SD is discussed in further detail to provide a contribution to academic research. Additionally, a DES model is created to simulate the behaviour if a supply chain is aligned. The simulation is based on a case study so that the solution holds strong importance not only for academic work but also for practitioners.

2 Drivers of Supply Chain Complexity: A Literature Review and a Case Study in the Drive and Control Industry¹

2.1 Introduction

Companies all over the world are faced by global complexity due to tremendous global competition, changing customer requirements, increasing deregulation, global financial crisis, natural disasters like in Japan and Thailand in 2011, turbulent international power dynamics and increasing emerging markets (Gunasekaran et al., 2014; Closs et al., 2008; Earl et al., 2010; Park et al., 2013).

While globalisation means sharing standards and practices across the globe, it also means dealing with complexities and uncertainties (Gunasekaran et al., 2014; Vahlne et al., 2011). In order to serve the complete supply chain from supplier to the customer over the whole world by managing SCC, managers and researchers need a greater understanding of SCC than what is offered by available theoretical frameworks about SCC (Gunasekaran et al., 2014; Groggaard, 2012).

Single or isolated manufacturers are unable to survive in the existing marketplace competition, but rather only through complete supply chains, where the managements' focus has to develop from the individual company to the complete supply chain. The consequence is a tremendous increase in SCC for the management (Gunasekaran et al., 2014; Wildemann, 2000; Pfohl et al., 2000). Numerousness, the variety of business processes and number of interacting partners like suppliers and customers are typical for an increase of complexity, whereas SCC is mainly controlled by internal and external drivers (Milgate, 2001).

KPMG (2011) provided a study involving 50 leading UK organisations to see what issues they were coping with. The first result is that the interconnected supply chains have exposed their network operations to unexpected risk. Second, many supply chains are unable to deal with the dynamics in business world. Third, sustainability activities lead to changes in operating models. These key aspects have in common that supply chains are stressed or challenged by additional complexity.

¹ Malina, S., Spinler, S., 2013. Management of Supply Chain Complexity: A Study in the Drive and Control Industry. Presented at EURO-INFORMS Conference, Rome/Italy, July 01-04, 2013

Even if supply chain capabilities have been investigated from different perspectives, there is still the need for further research of how companies deal with SCC, because products become increasingly interdependent and the scope of services extends in the global market environments (Early et al., 2010; Park et al., 2012; Gunasekaran et al., 2014).

Senior managers raise concerns that increasing complexity due to customised goods, global sourcing and distribution or technical innovations deteriorate a company's efficiency and thus reduce profit (Berman and Korsten, 2010; Hoole, 2006). This emphasises the need for an effective management of complexity (Gunasekaran et al., 2014; Desai et al., 2001; Kekre and Srinivasan, 1990; Meeker et al., 2009; Meyer and Mugge, 2001).

This research explores and proposes suitable strategies and methods for managing SCC from the perspective of an OEM. It helps companies with their performance through exploring theories and practices and thus to be competitive in the global market of the 21st century. Through managing and designing supply chain activities, supply chain directors are challenged to cope with SCC. They are trying to answer questions regarding the management of SCC in global supply chains.

Knowing the topicality and relevance of this research field for practitioners as well as academics, the following chapter explores details of SCC. However, to provide more understanding about this topic, a case study is conducted in an international company headquartered in Germany. The firm under study is in the machine construction industry which, plays a very important role for the German industry in total (IHS, 2014). It provides insights from the perspective of an OEM which has not been highlighted in literature, to the author's best knowledge.

The results of this research offer insights into existing theory as well as findings from practice. Section 2.2 explains the background of what complexity is and discusses definitions of SCC. Section 2.3 provides the case study strategy which is applied for this research including sample description, data collection methodology and analytical methodologies. While section 2.4 presents findings from the analysis, section 2.5 discusses management strategies and implications of SCC. This paper contributes to the

ongoing academic discussion on SCC and the management of it by exploring the understanding of SCC and its drivers from a managerial perspective.

2.2 Literature Review

2.2.1 Background and Definition of Complexity

The term *complexity* can often be found in literature. Definitions of complexity can be found in various social disciplines like organisational theory (Child, 1972; Whetten et al., 1979), operations research (Eglese et al., 2005) or complex systems (Simon, 1962; Klir 1985) and natural disciplines like chemistry (Whitten and Gailey, 1984; Kotz and Treichel, 1996) or physics and biology (Zhu et al., 2013; Mazzocchi, 2008; Kauffman, 1993). Further literature on complexity can be found for product design (Baldwin and Clark, 2000; Eckstein et al., 2014; Gupta and Krishnan, 1999; Tatikonda and Stock, 2003; Griffin, 1993, 1997; Wong et al., 2015), organisational design (Sun et al., 2015; Roh et al., 2014; Blau and Schoenherr, 1971; Price and Mueller, 1986; Daft, 1983; Scott, 1992), organisational behaviour (Cheng et al., 2014; Modrak et al., 2016; Payne, 1975), project management (Baccarini, 1996). Jacobs and Swink (2011) provided an overview of research disciplines concerning complexity. As this research paper is focusing on complexity of SCM, only a small amount of literature is available (Choi and Krause, 2006; Bozarth et al., 2009; Fisher et al., 1999; Novak and Eppinger, 2001; Rutenberg and Shaftel, 1971).

Research provides evidence supporting the notion that the aforementioned disciplines use individual definitions of complexity. This leads to the assumption that depending on the target the understanding and definition of complexity varies. Yates (1978) designates a complex system with one or more of the following attributes: (1) significant interactions, (2) high number of component parts or interactions, (3) non-linearity, (4) broken symmetry, and (5) non-holonomic constraints. In particular, the last three attributes characterise a high level of complexity, as they may influence the predictability of a system's answer (Flood and Carson, 1988). Transferring Yates' attributes to a supply chain, it can be revealed as complex system. Further attributes will be discussed in the section below.

We propose the following definition of SCC:

SCC is defined as capacities which are tied in the supply chain to fulfil customer requirements. Capacity can be understood as personnel capacity, machine capacity and supplier capacity.

Up to now the issue of capacity has not yet been addressed in literature as driver or criteria of SCC. Regarding the case study in this paper, Capacity fulfils the complexity criteria which are known from literature (Yates, 1978), especially in terms of non-linearity, broken symmetry and non-holonomic constraints. Today's organisational processes and customer requirements entail capacities distributed among the entire supply chain so that it is challenging to manage those holistically. Additionally, lots of information and data is available which needs to be processed for decision-making. Both aspects thus represent SCC, because the complexity lies within the intricacy of big data information as well as in the interconnectedness of the supply chain.

2.2.2 Supply Chain Complexity (SCC)

Wilding (1998) was one of the first using the term SCC. He defines SCC as *deterministic chaos, parallel interactions and amplifications*. Complexity is an important topic in SCM (Bode et al., 2015), as it is assumed that it negatively influences the the performance of operations (Bozarth et al., 2009), deteriorates decision-making (Manuj et al., 2011) and enhances disruptions (Chopra et al., 2014; Craighead et al., 2007; Narasimhan et al., 2009). Bozarth et al. (2009) offer the definition of SCC *as the level of detail complexity and dynamic complexity exhibited by the products, processes and relationships in a supply chain*. Table 2.1 gives an overview of further definitions for SCC provided in academic literature. Given the example that a typical automobile comprises more than 30,000 parts, Gunasekaran et al. (2014) argue that complexity results from the required number of component parts and the degree of services that customers expect. The *heterogeneously dispersed resources and complimentary competencies* lead to an increase of SCC throughout global supply chain (Fawcett et al., 2012).

Table 2.1: Definitions of complexity in SCM

Source	Definition
Choi and Krause (2006)	Complexity is manifested in the varied number of types of suppliers and their interactions
Bozarth et al. (2009)	Complexity is proportional to the number of parts and the degree of unpredictability in supply and demand
Fisher et al. (1999)	Complexity is manifested by number of systems and the rate at which products in the portfolio are replaced
Rutenberg and Shaftel (1971)	Complexity is represented by the number of product modules and markets
Novak et al. (2001)	Complexity is represented by the number of components within a product, extent of interactions, and degree of product novelty

Source: Jacobs and Swink (2011); adapted

Wilding (1998) provides a SCC triangle which covers the so-called deterministic chaos, parallel interactions and amplifications. Vachon and Klassen (2002) referred the definition of SCC to the dimensions of numerousness, interconnectivity and systems unpredictability. Their models showed that complexity and uncertainty have a negative influence on delivery performance. In general SCC has been considered as having a negative impact on operational performance (Aitken et al., 2016; Childerhouse et al., 2004; Heim et al., 2014; Hoole, 2005). However, certain kinds of SCC like extended product lines or new products and higher levels of customised products may open new markets and increase revenues and profitability (Aitken et al., 2016; Fisher, 1997; Bozarth et al., 2009). Indeed, managers need to understand the difference between positive and negative SCC and respond accordingly (Serdarasan, 2012). While much has been written about SCC and its negative impacts (Heim et al., 2014), less has been written about the management of SCC from the perspective of an OEM.

Closs et al. (2008) and Jacobs and Swink (2011) provide evidence that typical attributes of complexity in various fields of research are multiplicity and interrelatedness. In summary, the existing definitions of SCC cover the attributes of numerousness, dynamism, uncertainty, non-linearity, interaction and variety.

The field of managing SCC is not fully explored to date (Closs et al., 2008; Bozarth et al., 2009). Within the small amount of literature on SCC, the comprehensive management of SCC from a managerial view is missing. Despite managers need to understand how to manage a high degree of complexity if this belongs to their business strategy. From a managerial perspective it is necessary to identify the drivers of complexity to derive an efficient complexity management (Perona et al., 2004; Bozarth et al., 2009). This research provides a better understanding of SCC out of the machine construction industry which is missing to date to the author's best knowledge. In order to explore the understanding and appearance of SCC from a managerial perspective, managers primarily define SCC as the numerousness of products, processes and organisational structures. They perceive SCC further in all activities and initiatives of their supply chain. This leads to the conclusion to extend the definition of SCC by considering the needed volume of capacity in a supply chain in terms of personnel capacity, machine capacity and supplier capacity.

2.2.3 Types of Supply Chain Complexity

Any characteristic that increases SCC is called SCC driver (Serdarasan, 2013). Hence this term is also used in this paper to describe the sources of SCC. It can be observed in various forms. Static complexity is related to the interrelation and structure of the sub-systems which are involved in the supply chain like companies, business functions or processes (Serdarasan, 2013). Dynamic complexity occurs from the operational behaviour of the system and its environment. The third type is decision-making complexity which is a combination of both static and dynamic aspects of complexity (Serdarasan, 2013).

Despite difficulties in dealing with complexity in the supply chain, research supports that managing SCC results in achieving better supply chain performances (A.T. Kearney, 2004; Blecker et al., 2005; Bozarth et al., 2009; Gunasekaran et al., 2014; Koudal et al., 2007; KPMG, 2011; Perona et al., 2004; PricewaterhouseCoopers, 2006; Vachon et al., 2002; van der Vorst et al., 2002). Therefore, the integration of complexity management into SCM is absolutely necessary. After analysing and understanding the

drivers of SCC, the approaches of how to manage complexity in the supply chain can be developed and discussed.

Bozarth et al. (2009) distinguish between detail and dynamic SCC. While detail complexity refers to a concrete number of products or suppliers, dynamic complexity refers to the unpredictability or uncertainty of a system's reaction generated by a certain input and driven partly by the interconnectedness of the many parts of a system. This differentiation is mainly applied to research complexity in the manufacturing industry (Deshmukh et al., 1992, 1998; Frizelle & Woodcock, 1995; Calinescu et al., 1998).

Sivadasan et al. (1999, 2002a) differentiate between structural and operational complexity. Structural or static complexity refers to complexity of the structure of a product and the structure of the processes to supply, produce, and market that product. Operational (dynamic) complexity in supply chains associated with the uncertainty of information and material flows within and across organisations, i.e. internal and external sources (Frizelle & Woodcock, 1995; Calinescu et al., 1998, 2000). Literature (Serdarasan, 2013) offers further categories of SCC like technological, organisational, environmental and output complexity (Zhou, 2002), technical and flow complexity (Kaynak, 2005), internal and external complexity (Isik, 2011; Blecker et al., 2005; Kersten et al., 2006; Bozarth et al., 2009). With internal and external complexity drivers the focus is set to its origin (Childerhouse & Towill, 2004; Blecker et al., 2005). While the internal drivers are caused by impacts within an organisation and can be managed relatively easy as they are within the span of control, external complexity drivers are initiated through impacts which are outside the company's control like market trends or regulations (Serdarasan, 2013).

Due to the plurality of interfaces and processes to internal and external supply chain partners, the focus is set to external and internal SCC in this research. Seradasan (2013) provides some good practices of SCC management, although research on the situation in the machine construction industry – especially from the perspective of an OEM – is still missing. The target of this research is to present the typical complexity drivers from the perspective of an OEM and present solution strategies based on good industry practices. The result serves as a guideline for the development of a SCM system.

2.2.4 The Role of Product Complexity

SCC in general has received raising attention in research and practice (Choi et al., 2001; Eckstein et al., 2015; Jacobs, 2013, Wong et al., 2015). Based on existing research (Eckstein et al., 2015; Novak et al., 2001; Wagner, 2015; Wong et al., 2015), this research focuses on SCC from the perspective of an OEM out of the machine construction industry referring to product complexity, which arises from customisation, intricacy and variety of the firm's products (Schoenherr et al., 2010). Research on the effects of product complexity has provided mixed results. Product variety has been ascertained to downgrade performance in supply chains (Hu et al., 2008; Wong et al., 2015), higher inventory costs, reduced service levels and reduced delivery reliability (Closs et al., 2010; Eckstein et al., 2015). Contrary, product variety has also been linked to sales growth (Kekre et al, 1990), leading to balance reasons for managers between sales growth through increased product complexity and improved operational efficiency through product rationalisation (Salvador et al., 2002; Wong et al., 2015). Some researchers have similarly argued that product complexity may not only lead to negative performance results (Bozarth et al., 2009; Blome et al., 2014). Even if research provides some effects of product complexity, a comprehensive understanding of it is still missing (Blome et al., 2014).

Research (Gunasekaran et al., 2014; Jacobs et al., 2011) defines product portfolio complexity as *a design state manifested by the multiplicity, diversity, and interrelatedness of products within the portfolio*. It requires an increasing level of dynamic leaning and the flexible use of intra- and inter-organisational resources (Gunasekaran et al., 2014; Liao et al., 2010; Reuter et al., 2010, Zacharia et al., 2011). The origin of product complexity embeds upstream complexity, internal manufacturing complexity, and downstream complexity which all have a negative impact on a company's performance in case an effective complexity management is not introduced (Bozarth et al., 2009). An increasing level of product complexity needs multiple measures between information and material flow as well as governance structures (Holweg et al., 2008; Robertson et al., 2013). Earl et al. (2010) recommend an integrative analytical framework that weighs out aspects between different product features, rationality behaviours and hierarchical preferences over characteristics. New products are important for being competitive among multi-product companies. Further,

they enhance the growth of companies which belong to sectors with higher commitment to research and development (Gunasekaran et al., 2014) and finally new product development improve company growth in those sectors that absorb externally generated patents (Cucculelli et al., 2012).

Kotteaku et al. (1995) and Singh (1997) argue that a generally acknowledged definition of product complexity does not exist. While some authors define product complexity as the number of parts (Benton and Srivastava, 1985; Hagel, 1988), Griffin (1993) applies product complexity for the expertise requested to develop a product. As customers tend to purchase more individualised products, this development leads to more variants and an increase in product programmes. These variants need to be coordinated through sales and R&D and lead to a complex manufacturing process (Kirchhoff, 2003). Complex product variants need an efficient management of program planning as well as sourcing (Kestel, 1995; Westphal, 2000). Closs et al. (2008) argue that product complexity creates difficulties in supply chain processes which are related to product development, supply, manufacturing, delivery and support. If product complexity is considered as multiplicity of parts and components, the consequences for the supply chain need to be explored. This may have an impact on the management of suppliers which may be located all over the world, but also on distribution decisions to deliver the goods on time (Perona et al., 2004; Wildemann 1999; Kirchhoff, 2003).

An increase in the number of customised products raises detail complexity in the manufacturing environment and affects productivity and financial results negatively (Wong et al., 2015; Fisher et al., 1999; Krishnan and Gupta, 2001; Ramdas and Sawhney, 2001; Salvador et al., 2002). To reduce this internal complexity, researchers have investigated how manufactures can bundle product commonality and shared product platforms, while still meeting market requirements (Meyer and Lehnerd, 1997; Robertson and Ulrich, 1998). In general, supply chain processes with lower volume production processes are concerned by higher levels of detail and dynamic complexity. Detail complexity is increased by the manifold number of unique jobs that must be organised and dynamic complexity raises, because the manufacturing task comprises more complex interactions between different areas of the plant and *higher levels of decentralised decision-making* (Hill, 1994; Hayes and Wheelwright, 1979; Safizadeh et al., 1996; Duray et al., 2000). Literature suggests that shorter product life cycles

influence downstream and detail complexity by an increase in the number of parts and products that must be provided and serviced over a certain time (Fisher et al., 1999; Krishnan and Gupta, 2001; Ramdas and Sawhney, 2001).

Blome et al. (2014) found evidence of positive and negative impacts of product complexity on the relations between internal and external knowledge transfer and supply chain flexibility, indicating unique dynamics arising from complexity. As it is still unclear what role product complexity plays for SCC from the perspective of an OEM, this gap is addressed in this research.

2.2.5 Strategies of Supply Chain Complexity

With changing customer requirements, competition and regulations, SCC increases, as companies agree on strategic partnerships with suppliers, outsource services or explore new markets. The fast-moving increase of SCC seems to be supported and enhanced by customisation, innovation, globalisation, alliances and flexibility (BCG, 2006). To cope with SCC, literature mainly discusses *complexity management* and *complexity reduction* (Aitken et al., 2016; Brandon-Jones, 2014; Gunasekaran et al., 2015; Serdarasan, 2013; Galbraith, 1973, 1974, 1977). This means that complexity is extracted and minimised so that the remaining complexity is to be managed. Complexity prevention can be added as long-term strategy (Serdarasan, 2013; Wildemann, 2000; Sivadasan et al., 2002b; 2004; Kaluza et al., 2006). Sivadasan et al. (2002b; 2004) suggest that complexity can be managed by transferring it to other parties, charging for creating complexity, increasing resources for the elimination and finally by the avoidance of complexity. Sivadasan et al. (2002b; 2004) argue that the management and prevention of complexity depend on a company's resources like time, stock, IT systems or decision-making processes.

Perona et Miragliotta (2004) proceed similarly with the management of SCC. They develop a normative complexity model where the actual complexity is the result of basic complexity reduced by complexity reduction levers. In order to minimise disruptions in a system caused by complexity and smoothen supply chain processes, flexible manufacturing processes (Gordan et al., 1995; Sethi et al., 1990) or flexible supply with multiple suppliers (Bode et al., 2015; St. George, 1998) are discussed. Four

different types for complexity management can be identified in literature (Turner et al., 2005). They can be differentiated into accepting, controlling, reducing and avoiding complexity (Wildemann, 2000) and are explained in the following.

Accepting SCC

The strategy of accepting complexity means that only small potential effects on the supply chain performance can be realised in the supply chain through complexity management and high efforts are necessary to realise the management. This means that the desired advantage from complexity management does not justify high efforts for SCM activities (Blecker et al., 2006). In this case, the management of SCC is rather reactive and passive. When accepting SCC the parameters are not actively manipulated to reduce the level of SCC. Occurring complexity should be compensated on a company level of the supply chain (Wilding, 1998). Each company in the supply chain should define and follow up measures to deal with complexity and align its business concept to complexity requirements (Wildemann, 2000; Blecker et al., 2004).

Controlling SCC

The strategy of controlling complexity means that small potential effects on the supply chain performance can be realised in the supply chain through complexity management and small efforts are necessary to realise the management. Here, the management of SCC is rather a reactive approach, i.e. an active decrease of complexity should not aimed at by influencing the drivers of complexity, but they should be monitored (Blecker et al., 2006). This strategy presumes the systematic identification of changes to the existing level of complexity in the supply chain, because these deviations come along with incompatibility between the appearing SCC and the supply chain's capability to deal with SCC. As incompatibility has a negative influence on the supply chains' efficiency and performance, it is necessary to eliminate it. As the supply chain is aligned through this procedure, high reliability and visibility of business processes has to be ensured (Christopher et al., 2001). Through the controlling of information flows it can be reached that only useful information is communicated to supply chain companies which significantly reduces the level of perceived complexity and leads to an improved manageability of the supply chain (Wildemann, 2006).

Reducing SCC

The strategy of reducing complexity means that great potential effects on the supply chain performance can be realised in the supply chain through complexity management and small efforts are necessary to realise the management. In this case and contrary to the strategies discussed before, the reduction of complexity is rather a proactive and intense procedure in SCM to cope with SCC. The target of this strategy is a decrease of the occurring level of SCC so that supply chain structures need to be systematically optimised and synchronised (Vorst van der et al., 2002). This may cause intensive activities for SCM, but not a holistic redesign of the supply chain. A dramatic increase of necessary efforts is not wanted for the management of SCC (Wildemann, 2006).

The reduction of SCC can be reached by optimising the SCC drivers. Measures with an effect on SCC reduction are described in Section 2.5.3. Not only systems and information must be improved through the management of SCC, but also processes, business partners, products and services (Hill, 1996). This means that numerousness, variety and interrelationships must be systematically reduced. Redundant resources like supply chain partners with unemployed competencies or capabilities, supernumerary information systems or products must be identified and examined for their contribution to the supply chain (Blecker et al., 2006). All redundant elements must be eliminated so that the supply chain becomes lean and causes a dramatic decrease of SCC (Fisher, 1997). Therefore, it is important to understand and know all relevant processes and process owners in the up- and downstream supply chain. This procedure supports the decrease of non-value activities in the supply chain and leads to SCC reduction (Anderson et al., 2005).

Avoiding SCC

The strategy of avoiding complexity means that a great impact on the supply chain performance can be realised in the supply chain through complexity management and high effort is needed to realise the management (Blecker et al., 2006). In this case, the strategy is most proactive and intensive approach of all SCM strategies to deal with SCC (Seuring, 2004). SCC avoidance goes beyond all other strategies because the appearing degree of SCC is not influenced, but the degree of SCC is strategically defined to a desired level. This can be enabled by designing new supply chain designs

or defining parts of it under a special level of SCC, i.e. SCM decides the objects and drivers of SCC which have to be optimised. In this context, strategic supply chain networks play an important role (Lambert et al., 1996). The networks are a consequence of the systematic combination of selected companies in the supply chain. It is proposed to apply a common target system with a low degree of SCC and common strategies to fulfil the targets in the supply chain. Selected partners with outstanding profiles and plenty of competence to master SCC have to participate in the supply chain. Additionally, logistics and IT service providers can be included to achieve the defined level of SCC. All processes, systems, information flows can be designed in accordance with different parameters of SCC (Towill et al., 1993; Fisher, 1997). Intensive strategic partnerships in SCM support the alignment of the supply chain. As supply chains are exposed to a very dynamic marketplace today which drives SCC, these alignments are very important.

As complex supply chains are exposed to vulnerability, the implementation of risk management has to be analysed. Through globalisation and outsourcing trends which lead to an increase of supply chain structures and thus complexity, the level of risk has also increased. There is a number of factors which increase the level of risk and have to be addressed in risk management (Juettner et al., 2003; Wieland et al., 2012). First, the focus on efficiency (rather than effectiveness), second, the globalisation of supply chains, third, focused factories and centralised distribution, followed by an increased level of outsourcing and reduction of suppliers. These risk drivers can also be found as drivers for complexity. Therefore, it is clear that the strategies of how to manage risk and complexity are very similar. Supply chain risk can be defined as *any risks for the information, material and product flows from original supplier to the delivery of the final product for the end user* (Juettner et al., 2003).

Numerousness, products, variety, processes in and between supply chains and dynamics of the supply chain are important parameters of SCC and they are important elements to master complexity and relate to certain objects in the supply chain (Miragliotta et al., 2002, Seuring et al., 2004). By changing one of the parameters, a direct influence of the degree of complexity can be observed (Seuring et al., 2004) as well as an impact on the supply chain's performance (Beamon, 1999). SCM has the responsibility to provide an effective and efficient implementation of complexity management through a structured

controlling and manipulation of SCC parameters. Further, SCM measures shall be derived to resolve target conflicts and ensure an effective SCC management within the supply chain (Cooper et al., 1992).

In summary, managers can somehow observe and experience an increase of complexity, although they are unable to evaluate whether this complexity is valuable to reach business goals like company growth (“good” complexity) or if it is disadvantageous (“bad” complexity), whereby customers are not satisfied and the company is run into confusion. After the classification of the SCC, the decision can be taken if complexity drivers should be reduced, managed/controlled or avoided.

2.2.6 Research Objectives

After reviewing literature in Section 2.2, the author comes to the conclusion that research needs to be extended in the field of SCC for manufacturing companies. In their research, Wong et al. (2015) focus on SCC and performance measurement on the wholesale trade and recommend gaining results from other industries to increase generalizability.

Literature (Gunasekaran et al., 2014; Wong et al., 2015) recommends to further explore deficiencies of supply chain performance caused by complexity. Additionally, the role of product complexity as well as SCC and its behaviour in different industries is not yet fully investigated. Product complexity is seen as significant driver for SCC (Blome et al., 2014). Schoenherr et al. (2010) highlight that product complexity is primarily characterised by variety which is generated through customer-specific requirements or short product life cycles. Gunasekaran et al. (2014) argue that suitable performance measures shall be explored to cope with global complexity. As not all questions are answered, especially from the perspective of an OEM there exists hardly any research on the origins and management of SCC.

This research seeks to extend the understanding of SCC by achieving the following research objectives:

- (1) Identification of SCC drivers in the manufacturing industry from the perspective of an OEM:

This first objective is achieved by reviewing existing literature regarding definitions of SCC as well as its drivers. Serdarasan (2013) offers a review of SCC drivers, although further details need to be provided from the perspective of an OEM. OEMs are heavily confronted by global shifts and complexity which lead to cost increase so that leading companies of automotive supply chains invest and automate their supply chains (Heaney, 2015).

(2) Analysis regarding impact of product variety as one driver of SCC:

This part looks thoroughly into the development of a special product group from a globally-acting manufacturer out of the machine construction industry. A detailed analysis of product variety and its impact on SCM was conducted to highlight the risk of uncontrolled complexity drivers.

(3) Performance measurement of the supply chain in dependence of SCC drivers:

This part analyses which KPIs are used in relation to complexity and which managerial measures can be applied to cope with drivers from internal and external SCC and offers a framework to support managerial decisions. Learning the drivers of SCC in the manufacturing industry from an OEM, this research is to propose suitable strategies and methods for managing SCC. Good practices are provided for managers to cope with SCC.

In order to best provide a contribution to the aforementioned targets, a single case study was conducted within a global acting company located in Germany, which acts as OEM in the machine construction industry.

Lewis (1998) argues that especially in the development of new theory, case research is one of the most powerful research methods in OM. Researchers in OM have been demanding for greater use and application of field-based research methods to cope with the growing frequency and magnitude of changes in technology and managerial methods.

2.3 Methodology

2.3.1 Data Collection Methodology

This paper engages a longitudinal research approach that is based on a single embedded case study (Yin, 2014; Eisenhardt and Graebner, 2007; Handfield and Melnyk, 1998; McCutcheon and Meredith, 1993; Meredith, 1998; Stuart et al., 2002). Single case studies are often used in longitudinal studies because they support a greater depth of observation (Yin, 2014) with implications for management best practice and the development of theoretical insights (Ketokivi, 2006; Narasimhan and Jayaram, 1998; Karlsson and Ählström, 1995). Barratt et al. (2011) suggest that single case studies “enable the researcher to capture in much more detail the context within which the phenomena under study occur”. Yin (2014) highlights the benefits of utilising single case study provided detailed data access is given through the length of service that interview participants had (in this research: average of nearly 8 years). He further recommends case study research for using explanatory research questions (how, why) and the aim to extend theory.

Single case studies are recommended for either *extreme* or *unique* cases, but also for *representative* or *typical* cases (Yin, 2014). Taking the sample in this paper, the following arguments support a single case study: The exemplary company is out of the machine constructing industry. To the author’s knowledge there exists no research on SCC in this industry sector to date. Taking the many various technologies which are linked under one organisational roof, there is no other competitor on the market. According to Yin (2014), this unique phenomenon of different technologies justifies a single case study. Using data from a single company is not unique to this paper. The long history in management journals of publishing single case studies gives evidence of its acceptance (Doz, 1996; Marginson, 2002) or large sample disaggregated data from single companies (Dencker, 2009; Ethiraj et al., 2005; Huckman, Staats, and Upton, 2009; Sinclair, Klepper, and Cohen, 2000).

Concerning potential vulnerability of single case studies, thorough investigation and maximum data access is necessary to eliminate misinterpretation (Yin, 2014). Using data from a single company limits the generalizability of the study, although the

invaluable data presented here is difficult – if not impossible – to obtain from a larger number of companies.

Multiple sources of evidence are used in the data collection phase to preserve both construct and content validity. Thorough research design, data collection and data analysis can provide rigour and invalidate some criticisms of case-based approaches (McLachlin, 1997). Data in this research is collected through semi-structured interviews. One interview lasts between 1.5 and 2 hours. The self-administered questionnaire is based on an extended literature review and comprises nearly 40 questions. It contains both open-ended and specific questions. Specific questions are to be answered with a 7-point Likert scale. All quantitative and qualitative data is transferred into a central database and inconsistent data is sorted out. The draft of the questionnaire was tested by academics and practitioners to check validity and content. Notes from semi-structured interviews are strengthened by additional observations and documentations. The questionnaire is split into questions about the understanding, causes and measures of SCC and ends with few questions on the measurement of SCC.

Relevant sources were defined in advance and questions are formulated prior to interviews and observation. This ensures that correct data is used and appropriately organised, while minimising any social desirability bias on the part of the researcher (Fisher, 1993). The minimisation of social desirability bias reduces systematic errors resulting from the desire of respondents to avoid embarrassment and project a favourable image to others (Fisher, 1993).

Internal validity is pursued during the data analysis phase through the use of pattern-matching and explanation-building. External validity is supported with findings that are in line or consistent with existing theory (Yin, 2014).

2.3.2 Sample Description

The firm under study for this research (Table 2.2) operates in the machine constructing industry in Germany (for confidentiality reasons the name of the firm has been disguised). All information about the company is obtained either from the interviews or from internal resources like intranet or other company brochures. The machine building

industry in Germany is one of the most important industrial sectors. Highlighting the importance of this industry sector, Germany achieved more than 220 billion Euros in sales in 2017 and most jobs in Germany are offered in the machine construction industry (VDMA, 2017).

Table 2.2: Case description

Industry	Machine building sector
Key data	Sales: 6.5 bn EUR Employees: 38,000 Customers: >500,000
Locations	Sales network in more than 80 countries worldwide; nearly 70 production units in 25 countries; own sales and service offices in 39 countries
Product Portfolio	High number of variants; Differentiated products to dominate specific niches; >20 product groups for different technologies

With production sites and sales offices worldwide, it can be presumed how complex the management of material and information flows are throughout the whole supply chain (Fig. 2.1). The company in this research holds a market-leading position whereas a competitor with a comparable product range cannot be found. Benchmarks can only be conducted when single product areas are separated and analysed individually. The firm acts as OEM and business is characterised by a high individuality of customer requirements. This encompasses a strong specialisation of products and a differentiation of the total market. Further, the requirements for standardised part solutions and interfaces do also rise with the increasing integration of product solutions. Another aspect for the large product variety is the high demand for research and development (R&D), whereas technological possibilities for differentiation demonstrate a non-negotiable risk due to investment costs (ca. 5% R&D expenditure as a proportion of sales). While some customers seek for a technological solution for gears in the wind energy sectors, others request for valves with individual pressure options depending on the application.

Thirteen senior managers from logistics, sales and product development were interviewed (Table 2.3) out of the top management of different organisational units like corporate functions, business units, country units and plants to achieve greater quality and validity in evidence. In order to overcome observer bias and increase external validity (Voss et al., 2002), the interviews were conducted in different organisational units. Valuable contribution was provided by the interviews from logistics managers. They deliver important information, as they are deeply involved in the holistic logistics processes. Sales and product managers were interviewed as experts for discovering complexity drivers in terms of external effects and product development. Statements of the CEO were also implemented to better understand the problem of complexity.

Aside from the interviews several workshops among representatives of the senior management were conducted to specify drivers of the SCC and verify findings from the interviews. During the workshops, the development of product variety between 2005 and 2010 was analysed in detail and measures were decided how to control and reduce the amount of product variety.

Table 2.3: Participants of Interviews

Function	Organization/ Location	Responsibility	Seniority/ Business relationship
Logistics Manager	Corporate	Standardization of logistics projects worldwide	9 years
Logistics Manager	Corporate	Head of worldwide supply chain qualification programme	7 years
Logistics Manager	Corporate	Standardization of logistics projects worldwide	15 years
Logistics Controller	Corporate	Logistics Controlling, Target Development, Reporting	2 years
Logistics Manager	Business Unit	Target Responsibility for plants, implementation of logistics standards	1 year
Logistics Manager	Business Unit	Target Responsibility for plants, implementation of logistics standards	4 years
Logistics Manager	Business Unit	Target Responsibility for plants, implementation of logistics standards	10 years
Logistics Manager	Plant	Plant responsibility for material and information processes	4 years
Logistics Manager	Plant	Plant responsibility for material and information processes	7 years
Technical Director	Plant	Technical Responsibility for plant	17 years
Product Development	Business Unit	Product responsibility for defined product groups	4 years
Sales Director	Country Unit	Sales Responsibility of a European country unit	18 years
Sales	Corporate	Region America	5 years

Fig. 2.1: Supply chain of the manufacturer

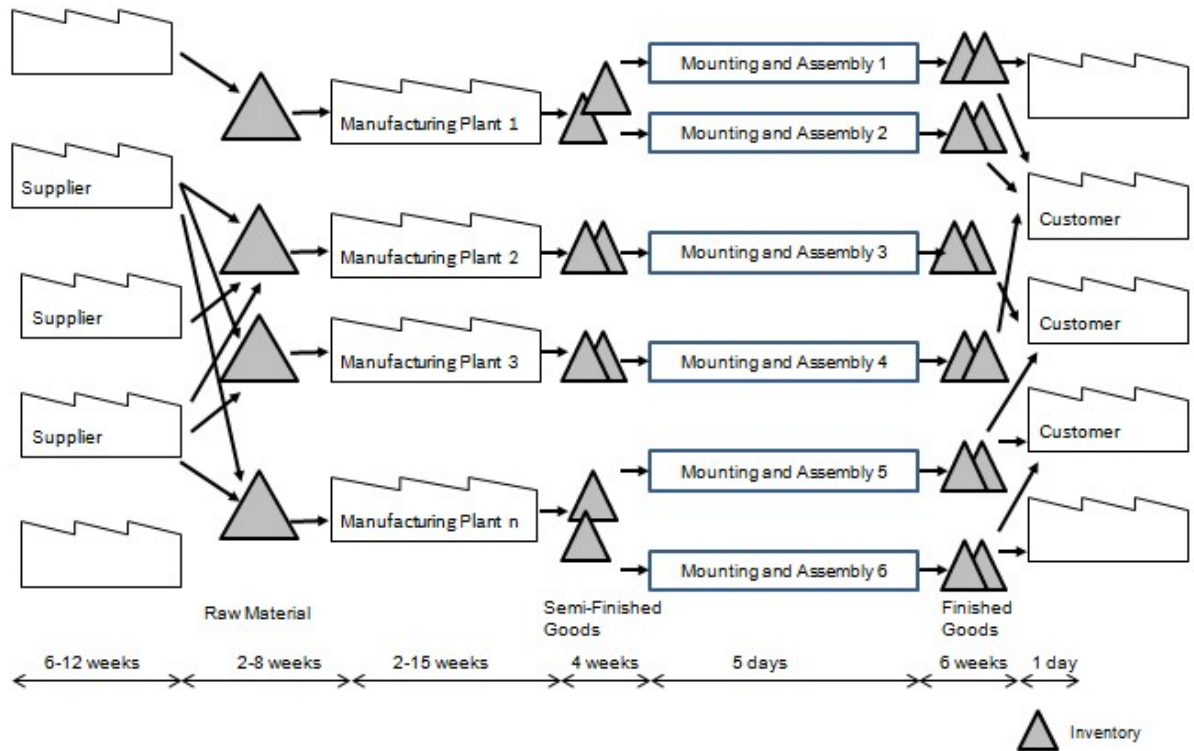

Providing the high number of product variants and technologies to the market, the company purchases raw materials from several thousands of active suppliers worldwide. Based on the interviews a differentiation between internal and external suppliers can be made. Internal suppliers provide modular components for further configuration of a system in another plant and external suppliers deliver raw material to manufacture modular parts for later assembly. Taking external suppliers, it varies if one dedicated supplier delivers to a local plant or several plants worldwide. This decision depends on the purchased product, e.g. semi-conductors where only few manufacturers exist worldwide, but also on purchasing conditions, where quantity is a decisive factor on the price. In order to receive standardised quality and meet the company's expectations with respect to delivery times, packaging or information transmission, suppliers are certified and categorised into preferred supplier, standard supplier or non-qualified suppliers. Suppliers distribute their products to the company's warehouses located in or near the plant. As this process increases inventory and is identified as one of the most time-consuming periods, it is necessary to integrate the supplier in the planning process.

The integration provides more transparency on the delivery performance of the supplier and improves the controlling of material management which may result in the reduction of inventory costs. Looking into manufacturing processes, the company holds a production network of about 70 plants worldwide. This network already demonstrates complexity due to its numerousness. Although some plants produce products which others do not, there exist many internal deliveries caused by the modular product architecture for customised goods. The internal deliveries present a dependency for other plants regarding the fulfilment of delivery performance. The interviews showed that among the locations there are differences in the business process like order management and the controlling of production processes which results in varying through-put times.

The through-put time of the mounting and assembly process is clearly influenced by the product variety. This means that a high number of material numbers (> 1 mio. numbers) needs to be administrated and planned for production. Further findings on product variety are described in section 2.4.2. Concerning downstream complexity, the company counts more than 500,000 customers worldwide. Customers are end users, distributors or other OEMs and located worldwide.

2.3.3 Data Analysis

Data analysis is responsible to conceptually interpret the original data under specific analytic strategies into new and coherent illustration of the research phenomenon (Schwandt, 1997; Yin, 2014). The research process started with defining research questions and choosing initial research constructs based on the preliminary practical and theoretical understanding of the phenomenon studied. While the organisation of the case represents the relevant unit as a whole, the smallest unit was the individual manager. At each level of analysis, different data collection methods were used, ranging from content analysis from interviews and workshops to secondary data analysis. While the interview process has already been explained, two more workshops were held to investigate the drivers and measures of SCC. Participants of the workshops and the interviews were nearly identical. The workshops focused on the categorisation of SCC drivers as well as on the conceptualisation of SCC management. All types of data were

applied as important sources of evidence when developing an understanding of SCC. The content analysis presumes that the information communicated was transcribed and coded to derive and generate hypothesis. Finally, the idea of this single case method was to contribute to a further exploration of SCC. Results in this paper are partly presented in tables, but also through quotations (voices of the field), since they enable the reader to better understand the context of the respondents' perceptions and experiences.

2.4 Findings

2.4.1 Review of SCC Drivers

Internal complexity is mainly driven by management decisions and the bias of organisational systems. It appears at each node of the supply chain as well as on interfaces on cooperation level. Division of work, cooperation, sourcing, product program and technology are examples for managerial decisions that have an impact on numerosness and variety of the supply chain processes (Bode et al., 2015; Serdarasan, 2013; Seuring, 2004).

Flynn and Flynn (1999) differentiate internal manufacturing complexity between detail and dynamic complexity. Potential drivers could be number of product party, types of business and production processes. Researchers explored that high levels of product variety result in longer manufacturing lead times, as well as to increased costs for the retailers (Thonemann and Bradley, 2002). Detail complexity is also driven by the number of unique parts, again negatively affecting performance (Fisher et al., 1999). By using commonalities of material parts and sharing product platforms, internal manufacturing complexity could be reduced, while meeting various market requirements (Meyer et al., 1997; Robertson et al., 1998).

External SCC is caused by uncertain demand and the high dynamics or volatility in the marketplace (Wilding, 1998). This results in a great number of different customer orders in terms of quantity, variety, quality and time. Supply chain partners are challenged to fulfil such a broad scope of requirements because they are limited in competence and capability. In order to handle this problem, they integrate additional

partners and extend the supply chain. Additionally, dynamic customer requirements like fluctuations in quantities or delivery times and changes in products cause frequent interactions to align the supply chain (Adam et al., 1998; Dooley et al., 1999).

This means that the number of managed business relations and processes increases as well as the number of interfaces and systems that need to be managed. The increase implicates a high degree of complexity for all supply chain partners and impedes the performance of the supply chain (Fisher et al., 1997; Vachon et al., 2004). This consequence demands that complexity management has to be integrated into SCM (Childerhouse et al., 2004; Gunasekaran et al., 2014; Tan et al., 1999).

Bozarth et al. (2009) define external SCC as the level of detail and dynamic complexity which is generated from the external supply chain, i.e. from downstream and upstream. Potential drivers for the downstream SCC include number of customers, volatility and variability of demand and length of product life cycle. Potential drivers for upstream SCC include number of suppliers, delivery performance of suppliers as well as the consequences of global sourcing. With the increase of suppliers, information and material flow increases as well as the relationships that have to be managed (Bozarth et al., 2009), i.e. that detail complexity increases appropriately. Another aspect for upstream complexity is the global extension of suppliers. The consequences of this globalisation leads manufacturers to many complicated issues in import/export, currency effects and cultural differences so that higher levels of dynamic complexity are expected (Cho et al., 2001).

Knowing the findings from literature, further drivers of internal and external SCC are explored in this case study and extend the existing theory appropriately. In this research drivers for external SCC are the high number of customers in different regions as well as their individual requirements. These requirements include specifications on the product, packaging and delivery days. The high level of volatility in demand requires flexibility from suppliers with respect to variety, quantity, quality and time. As existing suppliers cannot cover the requirements of customer orders, new external partners become part of the supply chain (Wilding, 1998). Regarding globalisation, suppliers are spread worldwide and influence delivery times. Precisely, the number of partners in the supply chain increases as well as business processes and raise the level of complexity which negatively influences the performance of a supply chain (Fisher et al., 1999;

Vachon and Klassen, 2002). Managers confirm that with an increase of complexity drivers, complexity may perceive a dynamic character. A logistics manager states: "...with the increasing number of product variants it becomes more difficult to have the right parts in the warehouse. Inventory which is not demanded by customers cause high inventory costs and reduces the company's profitability". This phenomenon is shown in literature as separate category of complexity types (Bozarth et al., 2009), but is not further discussed here. Especially the high uncertainty in demand demonstrates an important challenge for the managers in this case study. The main reason is the shortening of economic cycles which affect a company's profitability like high costs of inventories or overcapacities. Regarding the management of internal complexity, the CEO states: "When we were faced by a crisis in 2009 and if we believe the current economic decrease, we are forced to react much more flexible and faster in terms of personnel and technical capacities. This dynamic forces us to cooperate with our business partners more intensely and adopt our processes. This will definitely increase supply chain complexity as we have to process more information and provide it to the places where it is needed."

The answers of the interviews showed that all managers are faced by SCC to a significant degree and support the argument that the management of SCC is of high importance. The logistics controller argued: "The data volume and information flows influence the speed and processing of the daily work enormously. I see great potential to improve our quality in evaluation and analysing data, when the variety of employed ERP system is harmonised and reports can be generated automatically." Although they confirmed various initiatives in SCM they stressed to standardise business processes among all organisational units of plants and country units. Activities to manage supply chain complexity are further caused by low customer satisfaction, increase of semi-direct deliveries (SDD), non-standardised logistic processes throughout the whole organisation in order management, qualification of logistic employees and a high level of inventories. Aiming at a successful management of SCC by considering strategic aspects, the interviewees answered that the management of SCC should be part of the business strategy with clear targets on a high level of customer satisfaction and to remain profitable with a low level of inventories. Uncertainties in demand can better be coped with, when the manufacturer is aware of it by having appropriate transparency through intensifying communication with customers and suppliers.

SCM is seen as important part of competitive strategy to improve organisational productivity and profitability. Organisational performance measurement and KPIs or metrics have been focused from researchers and practitioners (Gunasekaran et al., 2004). The importance of these measures and KPIs have to be carefully analysed, because they affect strategic, tactical and operational planning and control. The strategic, tactical and operational levels are the hierarchies in function, where policies and trade-offs can be determined and appropriate control can be executed (Ballou, 1992). This hierarchy is related to the time horizon for activities and the relevance of decisions which influence the different levels of management (Rushton et al., 1989). Measures on strategic level influence top management decisions, usually based on policies, corporate financial business plans, competitiveness and fulfilment of organisational goals. The tactical level manages resource allocation and performance measurement versus targets that are specified at the strategic level. The performance measuring at this level offers feedback on mid-level management decisions. Measurements on an operational level demand a strict data base and examine the results of decisions coming from low level managers. Usually, workers and supervisors are set operational targets that will lead to the realisation of tactical targets (Gunasekaran et al., 2004).

Perona et al. (2004) argue in their research that the way of how companies manage their system complexity has a deep impact on how well they perform. They suggest a model where the ability to control complexity within manufacturing and logistics systems can be seen as core competence with the target to improve efficiency and effectiveness in a supply chain. The observed metrics are named by the interviewees in this case study. It is obvious that the KPIs can be differentiated into operative performances and complexity-related variables. Adani et al. (2002) use a similar structure in their research about household appliances, although the results of the metrics vary in this case. With this structure, the allocation of metrics to the aforementioned strategic, operational and tactical level can be enabled. Based on the identified drivers of SCC the following KPIs could be identified in the case study and are shown in Table 2.4.

Table 2.4: Identified drivers of SCC and measuring KPIs

Drivers	KPIs
<p>Internal Complexity</p> <ul style="list-style-type: none"> • High number of material numbers • Widespread production network • Complex production network within one location (e.g. one machine for different product families) • High number of internal deliveries due to production strategy • High level of unstructured data and different IT systems (e.g. controlling, information on delivery times) <p>New:</p> <ul style="list-style-type: none"> • Lack of communication within organisation <p>External Complexity High number of customers in different regions</p> <ul style="list-style-type: none"> • Suppliers in different regions and variable delivery times • High number of different business processes • High number of suppliers • High number of customers • High level of uncertainty in demand <p>New:</p> <ul style="list-style-type: none"> • Information complexity: Kind of information requested from customers and suppliers (e.g. order tracking, product availability) • Service complexity: New types of services requested (e.g. remote maintenance, preventive or predictive maintenance) 	<p>Operative Performances</p> <ul style="list-style-type: none"> • Logistics costs (% of turnover) • Total coverage time (sales vs. inventory) • Fulfilment of lead-time • Delivery performance of suppliers • Delivery performance to customers • Through-put times in production • Through-put times in logistics • Level of inventory • Administration costs • Production costs <p>Complexity related variables</p> <ul style="list-style-type: none"> • Number of suppliers • Number of customers • Number of products • Number of plants • Number of ERP systems • Number of employees <p>New:</p> <ul style="list-style-type: none"> • IT interfaces and digitalisation (IT costs, throughput times: compatibility of infrastructure and connection with suppliers and customers) • Capacity (personnel costs, IT costs): Evaluation of big data for deciding on maintenance strategy (throughput times, personnel capacity)

This paper focuses on the SCC drivers which are new in literature. The majority of managers argues that the lack of communication within the organisation represents an internal SCC driver. They explained that changes of logistics processes, e.g. standardisation of incoming goods processes are not known or implemented in the organisation so that this has a negative impact on the KPI for measuring supply chain processes, e.g. supplier's performance. Further, strategic targets were not clearly communicated and understood along all hierarchy levels so that delays occurred for fulfilling the target. A lack of communication and thus missing information leads to a slowdown of process performance. Installed counter-measures like detailed monitoring of the process lead to increased SCC. This case study further gives evidence of two new external SCC drivers. The first one is the kind of information which is requested by customers and suppliers. Today, customers request detailed information regarding order tracking. Opposite to the consumer goods industry, where this information is available as standard, this request is quite new in the drive and control industry. The complexity

lies with the generation of information which has to be prepared by providing a suitable IT infrastructure including the involvement of forwarding agencies. On the other hand, suppliers request access to data and IT applications from the manufacturer regarding inventories so that they can provide their material according to the manufacturer's needs. Again, the provision of interfaces and IT infrastructure as well as the provision of the relevant data represents SCC. The next new SCC driver lies in the types of services which are requested from customers. An example of such services is demonstrated by preventive and/or predictive maintenance per remote. This type is a new business model and through missing experience in this field the question has to be clarified which maintenance option is the most beneficial one. With this intricacy in knowledge and experience this issue is regarded as driver for SCC.

Along with the new SCC drivers, it has to be discussed which KPIs are now relevant for monitoring the drivers. All new drivers require additional capacities in personnel and may impact through-put times. Additionally, technical infrastructure has to be provided. While personnel capacities and through-put times can be reflected in existing KPIs, there is no KPI for measuring technical infrastructure. Here the manufacturer monitors IT costs. The managers argue that when monitoring the listed KPIs they gain an indication of where measures have to be defined so that operative performance can be improved.

The following examples show results from the manufacturer from SCC activities: Taking the product example from Fig. 2.3, it emerged that out of a total of nearly 120 variants, 50% of the variants are hardly sold. This gives evidence to analyse if product parts may be phased out so that inherently the number of suppliers could be reduced. Further, due to this effect inventory costs can be reduced which leads to a positive effect to the development of logistics costs. The development of this effect is shown in Fig 2.2.

Fig. 2.2: Development of number of suppliers and logistics costs for controlling unit

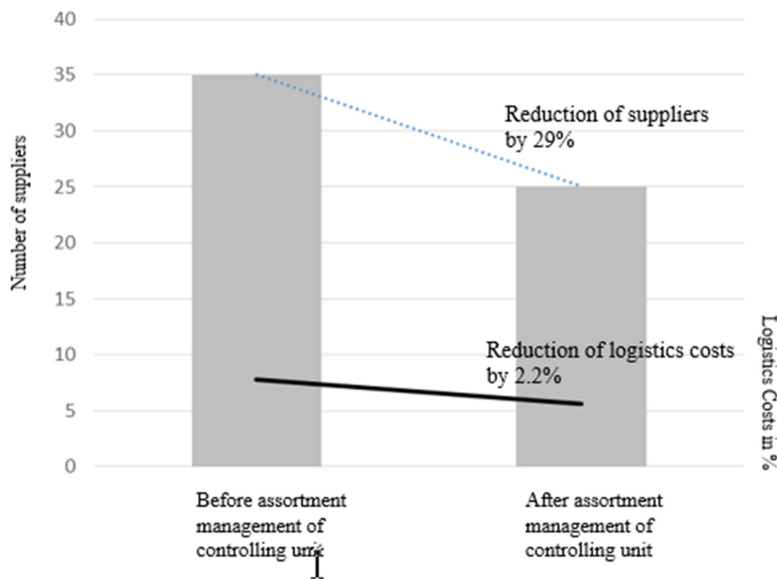

The implementation of a so-called assortment management, i.e. focus on products which are highly demanded in the market, leads to a reduction of logistics costs as well as to a reduction of suppliers which need to be administrated. Additionally, employees have to be trained regularly on existing supply chain processes in information and material flow. These trainings not only mean additional capacity for employees, but also capacity for trainers who train the people. Furthermore, additional capacities are employed for planning cross-functional activities coming out of special customer requirements. Contrary to the past, special customer requirements have significantly increased. This may affect the product itself or the service to the product.

In summary, these new drivers represent a new dimension in the field of SCC, as they influence supply chain processes in terms of dynamics and flexibility. With this new knowledge, managers have to rethink their ongoing activities for managing SCC.

2.4.2 The Role of Product Variety for Supply Chain Complexity

In order to generate sales growth by developing new products, managers are faced with an increase of product complexity through new features and variants. This increase of variety has to be weighed out against an operational efficiency through product rationalisation (Salvador et al., 2002). Essentially, the complexity of a product portfolio

in a company is accompanied by manifold management decisions in different functions over long periods so that the management of product complexity can be a challenging task. A reason is that outcomes in relation to complexity are not always clear when making decisions or trade-offs (Closs et al., 2008). Difficulties of product complexity are created in the execution of a supply chain process which is related to product development, supply, manufacturing, delivery and support. Contrary, the complexity caused may lead to additional sales through increased product differentiation (Kekre et al., 1990; Quelch et al., 1994). Product complexity is not well explored, often with the remark that less complexity is better. For example, some researchers have investigated inventory and risk pooling benefits component commonality (Fisher et al., 1999; Hillier, 2000). Meyer et al. (2001) focused on cost reductions in procurement coming from reducing unique parts. The influence of product architecture on the firm's ability to communicate effectively and coordinate design activities is analysed by Galvin et al (2001). Finally, the effects of complexity on product development cost were examined by Clark et al., 1991. Closs et al. (2008) analyse in their case study research a theory of competencies for product complexity. They define product complexity as *the collective set of decisions, supporting processes, value systems, and initiatives pertaining to determining and implementing the most effective product portfolio (i.e. mix of product variants, feature sets, and component choices)*. Closs et al. (2008) further argue that the combination of decreasing return of sales and increasing costs due to complexity offer potential for an optimal level of complexity in a firm's product portfolio.

Due to the high share (< 80%) of customer-specific products in the firm under study, the preferred production method is modularisation. This enables purchasing and producing different components independently, while satisfying customer-specific requirements through final assembly (Ernst et al., 2000). The following analysis emphasises the problem of product variety. Taking an electric controlling unit as example (Fig. 2.3), the final product comprises five basic components. The components are to be understood as electronic interfaces, wavers, controller, masterboards and software components. Each of these components allows between 30 up to 110 variants. The final evaluation showed 114 potential variants, whereas the sales volume of 59 variants is less than 10 pieces.

The product manager explained: "...we had four options of how to control existing product variants: First, delete the product number from our system, second, to integrate

the variant into another variant and restructure our product groups, then assign it to a core program to push it more into the market and finally do nothing.” Through deleting and integrating product variants, part numbers could be reduced by 40-50% within some product groups with the result that the product development process was designed to the extent that unnecessary variants of new products are eliminated in advance. Only if the awareness of SCC is transparent, the right decisions can be made to improve the manufacturer’s performance.

Fig. 2.3: Variant analysis of controlling unit

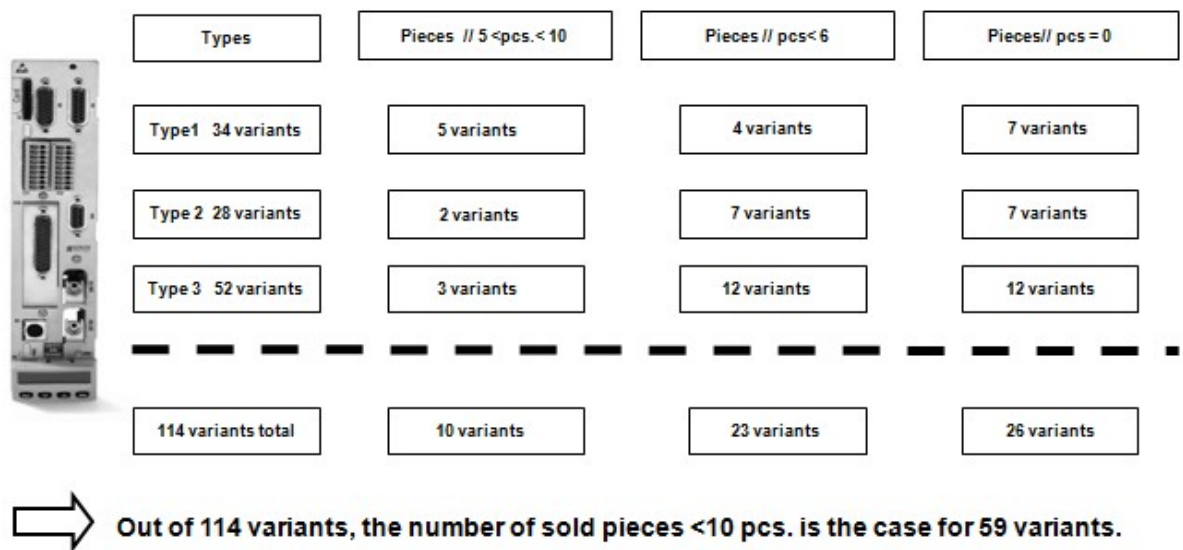

This case offers four aspects which increase product variants and thus lead to an increase of SCC:

Technological change

Due to price increases of raw material or limited resources of it, alternatives are interesting for the manufacturer. Taking the development of the steel price which more than doubled between 2002 and 2012 (Federal Statistical Office, 2012), new products are developed with less share of steel or replacements through other materials. The senior product manager states: “Today our customers require specific and flexible product features for their individual requirements so that we have to cooperate with many new suppliers which leads to an increase of complexity.” One interviewee states that aluminium which offers advantages in weight was 30% more expensive than steel in 2010 and steel prices are predicted to remain on the same stable price level until 2030

(McKinsey, 2017). The product manager continues: “As long as we can replace aluminium by steel due to price reasons, we do that. However, in some cases the aluminium parts cannot be avoided due to their physical attributes so that results in an increase of product variety.”

Environmental challenges

The increasing awareness on resource consumption and climate change require new product variants to comply to political regulations. This challenge leads to new products or even new materials which need to be sourced from suppliers and provided to the plants. The CEO of the company under study states: “...wind power is environment-friendly and can help to reduce CO2 emissions and mitigate climate changes. As a high-tech precision component supplier to the industry we support the realization of this challenge.”

Market diversity

Especially the energy sector – which is a quite new division within the company – drives complexity due to the need of new suppliers or product developments which have to stand extreme weather conditions. Extreme weights and sizes of special gears require defined processes in production and transportation which lead to an increase in SCC. Another new sector is the increasing level of digitalisation in machine construction industry. While new services like remote maintenance or disruption management can be offered by an increased level of electrification, this means also an increase of product variety.

Built-to-engineering, built-to-order projects

The manufacturer in this research provides customer-specific products or offers complete solutions which are especially engineered or built for specific projects. In order to fulfil this requirement, specific technology outside the initial core competence is purchased to fulfil the order. This means also that additional know-how needs to be processed which results in an increase of SCC. For example, shipping companies which ordered hydraulic parts for their cruise liners requested also mobile applications for their entertainment area. This has been a completely unknown field for the manufacturer where additional know-how had to be built up or even acquisitions had to be undertaken.

2.4.3 The Role of Performance Indicators for SCC

Complexity management is seen as part of SCM and obligatory for a successful implementation in SCM in today's marketplace of increasing complexity. It should not be executed at the company level, but rather at the cooperation level within the supply chain. The integration and development of complexity management supports the avoidance of inefficiencies in the supply chain (Serdarasan, 2013; Blecker et al., 2006).

An effective design of the supply chain and its continuous optimisation are general targets in SCM (Wildemann, 2000). In order to achieve these, supply chain partners focus on their core competencies, share resources and aim a high level of integration by implementing inter-organisational planning and controlling systems, organising cooperation for product design, synchronising stocks and transportation data or standardisation of packages (Wildemann, 2000; Lambert et al., 2000). By generating various activities for the improvement of the supply chains' performance, relevant deficits can be highlighted from the perspective of complexity (Wildemann, 2000).

However, measures to improve the flexibility and thus performance of a supply chain can lead to the integration of additional partners, create redundant resources or increase the need of coordinating interactions (Serdarasan, 2013). These measures lead to an increase of SCC, which influence the supply chains' cost-efficiency. Further, a high level of SCC weakens the flexibility, quality and delivery performance of the supply chain; i.e. that the target conflict is clear. So far, SCM has hardly targeted at the reduction of SCC (Serdarasan, 2013; Blecker et al., 2006).

Quite often the implementation of SCM is undifferentiated, because SCM does not offer strategic or operative recommendations regarding optimal measures of SCM considering special business circumstances that are characterised by specific levels of SCC (Serdarasan, 2013; Miragliotta et al., 2002). This leads to insufficient measures to reach the supply chains' targets and improve its performance. As nowadays complexity management is often limited to a company level, improvement effects have thus only a limited effect on supply chain performance. This means that there is still potential to eliminate inefficiencies and reduce complexity (Bode et al., 2015; Serdarasan, 2013; Towill et al., 1993).

The investigation in this case study highlights that the company uses both performance indicators and complexity-related KPIs to monitor SCC (Table 2.4). Especially the complexity-related KPIs – e.g. number of suppliers, products or customers – offer a direct insight into the development of the complexity. Generally, the feedback out of the interviews is that the greater the level of number is the great the level of complexity. Few examples are given:

- Number of suppliers:

The corporate head of purchasing informs that for direct production material, roughly 2,500 suppliers are listed worldwide. They deliver at least twice a year for a period of the last 5 years. He confirms: “We have to spend a lot of time for a huge number of negotiations, IT supplier integration and supplier qualification. The target must be to reduce the number of suppliers and also product varieties so that these activities become more efficient.”

- Number of products:

The investigation in the firm under study shows that more than 1 million products are offered to customers. The logistics manager states: “This huge variety represents a high level of complexity, because all these parts need to be sourced, manufactured and transported to the customer. All these processes have to be administrated. Here we have great potential through product standardization or reduction of variety that inventory costs decrease or that transportation and packaging costs decrease. We expect savings, because packaging can be standardized and transportation can be organized in shorter frequencies so that customers receive their goods earlier.”

- Number of customers:

As written in the case description, the manufacturer counts more than 500,000 customers worldwide. According to the sales managers, lots of them have customer-specific requirements e.g. delivery conditions or product requirements. This means also a high level of administration effort. However, as growth is dependent on the sales increase, the complexity which is generated by an increase of customer numbers is a good example where complexity is accepted.

Conducting the interviews in the firm under study, it emerged that a high level of capacity is needed to generate decision. This procedure is not only time-consuming but also inefficient.

2.5 Implications for the Management of Supply Chain Complexity

The research explored a number of internal and external drivers of SCC in the drive and control industry. An important role plays the high number of customers and suppliers located in different regions in the world. This means that due to the numerousness of up- and downstream partners, a high level of data management is necessary to administer these in the IT-system and manage relationships. Additionally, the heterogeneity of the customers tends to increase product variety considering customers' individual requirements. This variety is reflected in a high number of material numbers which needs to be administered in terms of purchasing from suppliers, planning in production schedules and monitoring of inventory. The high level of variety leads to a higher level of retooling in production and a negative impact of productivity. The sales director states: "We as market leader have a commitment towards our customers. This means that we have to fulfil their requirements. It is one of our core competences to find customized product solutions". As customised products often lead to the fact that technical requirements need to be tested with regard to product quality, standard processes cannot be applied and executed and create thus a higher level of supply chain complexity. It is not only the test of the product quality, but also a reliable supplier which is to be found or a special transport due to size and weight to the customer's location. A logistics manager explains: "when a large gear for wind turbines has to be dispatched, we need extra qualified people and especially machines for loading the truck. Sometimes we have to block some areas in the production hall when these large and heavy gears are collected. It is a completely different process compared to the despatch of small valves which can be packed into boxes and dispatched via parcel service."

Relevant drivers of SCC in this research are found in the lack of communication within the organisation and the widespread manufacturing and sourcing network. Findings show that the process of order processing is handled differently within the organisation.

In some organisational units, responsibility for this process is at sales and in other units logistics department is responsible. This situation leads to the result that logistics may provide a different delivery time to the customer than sales, because logistics is interested in low inventory, but sales rather in prioritisation of customers. This means that inventory may be kept regarding the importance of the customer and leads to higher costs of inventory. A plant manager explains: “Through the difference in responsibilities, we do not have only different contact persons for our customers, but also different impacts on cost performance or the handling of delivery times.”

Further, the research explored SCC in the production network. This means that one machine is used for the production of different product families, whereas ERP systems support the production schedule. While the ERP-supported production schedule does not necessarily consider requested delivery dates from the customer but only production efficiencies, planning of delivery dates becomes more complex. Additionally, the high number of internal deliveries leads to prolonged delivery times and an increase in transportation costs. Internal deliveries are caused by the production program of the plants. The technical director explains: “Our highly engineered products require a high level of in-house production depth which cannot be provided in each of our plants worldwide. However, we have to supply all our plants worldwide with the complete product program so that we have a high share of about 50-60% of internal deliveries. Shipping of the heavy goods is preferably done by sea freight and takes extra time for transportation”.

With the implementation of a special product program (assortment management), the manufacturer tackles now an external driver of SCC, namely managing uncertainties in demand. Often, customers complain that products are not available and delivery dates are not kept. The target of the special product program is to sort and cluster all products according to a certain structure and based on this structure, delivery dates are agreed and have to be kept from the manufacturer. The structure comprises three assortment types. Assortment 1 contains mainly series products and shall be delivered within 5-10 days. The decision for the delivery time is agreed between sales and product management so that it can be ensured that the delivery time is in accordance of what the market expects. Assortment 2 includes mainly standard products and shall be available within 10-15 days. Standard products are not as high-runners like in Assortment 1.

Again, sales and product management decide on delivery time as well as on the product parts which finally belong to this group. All other or remaining parts belong to Assortment 3. Here, mainly customised or specific products are included, so that delivery times will first be checked on the engineering and production effort and then communicated to the customer. A product manager states: “I remember when we started to realise this idea, I had to go through endless lists to decide which product belongs to which assortment class. However, this offered really the chance to nominate the products into this class of delivery time what the customer wants. And on the other side, no movers can also be identified and eliminated. We have two main effects: The planning of delivery times is dramatically simplified and the customer can rely on the delivery time. Our suppliers are involved by receiving demand forecasts so that they can plan their capacities accordingly.” The logistics manager adds: “With the information in the forecast, the supplier can plan quantities for material in case of increasing as well as of decreasing demand so that inventory can be kept at a minimum level. Usually, the supplier receives the information electronically and regularly”. When summarising the effects of the implementation of an assortment management, positive impacts on operative performances like reduction of logistics costs, delivery reliability, but also on reduction of numbers of suppliers as well as the high level of product parts can be observed. However, on the other hand, additional processes have to be installed to create a reliable forecast plan from customers which can be provided for suppliers and their material availability. These additional processes have to be designed efficiently so that promised delivery times can be kept. Therefore, the following hypotheses can be offered:

Hypothesis 1a: Assortment management reduces numerousness in product variety and suppliers.

Hypothesis 1b: Assortment management increases supply chain capacity by structured sourcing and planning processes.

Occurrences like financial crisis or the nuclear catastrophe in Fukushima are described as exogenous shock in this paper. In this case study the consequence of the financial crisis was reflected by a high level of customer order cancellations and increasing

inventory. Cancellations coming from customers are caused by full warehouses they had themselves and missing signals of a growing market. Some other countries like China withdrew national construction projects so that e.g. hydraulic parts for baggers were not accepted for delivery. Taking the nuclear catastrophe in Fukushima the company of this research had increasing problems with receiving parts from their suppliers which are located in this region. Especially electronic parts for machine controlling units are produced there and for a few parts, single suppliers in the world are unable to deliver. In this situation, the SCC is not generated by the number of suppliers, but with the vulnerability of the supply chain in terms of disruptions with less suppliers. The dimension of a supplier's failing resulting in non-deliveries to customers is difficult to predict. Regarding delivery performance and logistic costs, these impacts increase internal and external SCC. In order to control inventory costs, a strong integration of suppliers through the exchange of logistic data is necessary. Customers deliver important planning data to create a resilient demand planning. The sales director explains: "Usually we receive a forecast planning from our biggest customers. Of course, this forecast is only an indication for the needs of the next 12 months. In order to recognize deviations which may have an impact on capacities and thus delivery times, we contact these customers once a month and discuss their topical planning situation." Considering the effects on lead times in this case as example out of the machine construction industry, the time to react on economic changes in times of decreasing demand the supply chain is considered as too long until reductions in purchasing towards suppliers are adapted to the actual demand. However, the interviews also highlighted the high level of vulnerability of the supply chain in terms of any disruptions in case of exogenous shocks. Some parts are available only from single suppliers in Japan. In this case, the SCC driver is not the numerousness of suppliers, but the high level of vulnerability regarding delivery performance. Managers argue that it is very important that these suppliers fulfil their delivery commitment to fulfil the company's commitment towards its customers. The purchasing manager states: "When the Fukushima accident occurred, the plant of a special semiconductor supplier broke down so that we were not able to source those parts from him any longer. We were not prepared to such a situation and had to implement a special team searching for any replacement products and suppliers. This cost us a lot of time and extra effort in terms of production processes to come to a solution." As such disruptions lead to additional

activities in the functional areas like logistics, purchasing or manufacturing, the following hypotheses can be offered:

Hypothesis 2a: A supply chain with a high level of complexity is exposed to a higher level of vulnerability in case of an exogenous shock.

Hypothesis 2b: A low number of suppliers represents a high level of SCC in case of exogenous shock.

The interviews for this research are conducted in different functions of the company. Regarding external interfaces of the supply chain like suppliers and customers it is very important that information e.g. agreed delivery concepts with suppliers, changes in demand (e.g. quantities or product parts) are communicated and made transparent. The sales director explains: “We hold stock for certain components for customers where we receive a forecast planning. However, final details of product configurations like pressure settings are communicated only at very short notice and is not forwarded to production for example. Therefore, we implemented now regular meetings with colleagues from sales, logistics, production, controlling and R&D to ensure that each function receives the information they need to satisfy the customer. Here we need to work together very closely.” Group-based targets in general, but concurrent and cross-functional cooperation of SCC in particular, is not only beneficial to manage external SCC, but also to manage internal SCC. In this case study group-based targets represent a common target for employees within the same group; e.g. all logistics planners receive the same target for the implementation of the goods receipt process incl. standardised ERP templates. Cross-functional targets are provided to employees from different departments like logistics, sales, production and purchasing in the same manner. An example is the reduction of inventories. While in the past, only logistics was responsible for the reduction of inventories, now this target is given also to sales, production and purchasing managers. While production had an interest to produce quantities to increase efficiency, logistics never had the chance to reduce inventory. This is valid in a similar way for purchasing: while purchasing ordered high volumes to realise purchasing ratios, logistics monitored only increases of raw material.

The interviews showed that single functions of the company are not or only partially informed about activities of other functions in the company which influence SCC. An example from this case study is that purchasing focuses on pricing with suppliers. This means that better prices are often achieved by high-volume purchases. However, logistics monitors also the performance (in-time deliveries and logistics failures like an incorrect quantity or product) to avoid missing parts for production or costs for returns. Further, while sales focuses on increasing sales, it is also necessary to check with R&D on the feasibility for customised goods or with production on availability. As the aforementioned functions are faced by individual complexity drivers like planning activities per business function, concurrent and cross-functional cooperation with group-based targets allows reacting efficiently on internal and external SCC. Through consequent and early involvement of R&D through regular information exchange, product development can avoid SCC at the beginning of product development, because complicated production processes or the identification of further suppliers for additional product specifications can be avoided. The same is valid for purchasing which needs to know logistic requirements. In many cases the product price of the supplier is low, but the manufacturer has to carry unnecessary handling costs for unpacking. These handling costs can be avoided if the supplier delivers the goods packaged as per the manufacturer's specification.

Although through the provision of compatible IT systems quantities of data are produced and available, capacity plans and product availability can be made faster and more efficiently. It is necessary that only relevant data is used by responsible managers. A logistics manager states: "In the past we made our production plans mainly on sales forecasts based on monetary volume, i.e. production had no indication which quantities/pieces are behind the monetary values. The transfer to pieces and consequently to capacities which are needed is quite difficult to coordinate. Even if machines provide sufficient capacity, additional shifts are not spontaneously available due to legal restrictions or regulations with the workers council". Results support managerial decisions concerning personnel capacity or development of inventories. The research explored that before implementation of a regular program planning meeting, each function followed its own targets. This meeting has the target to decide on the manufacturing program based on market demand, i.e. that now the customer demand is the trigger for the manufacturing program and no longer pure efficiency targets from

production alone. Conflicts which are caused by individual targets in the different departments e.g. low level of inventory in logistics vs. high level of efficiency in manufacturing, lead to the situation that processes have not been managed efficiently from the overall perspective of the company. Through the regular exchange of the relevant information, i.e. sales forecast plannings, level of inventory or personnel capacity, product engineering, an improvement of the formerly shown KPIs for operative performance could be observed. Even if it is known from literature that information exchange is beneficial for an organisation's performance, the importance of the installation of such focused teams with group-based targets has grown. While departments worked on individual targets in the past, they now work on common targets and activities which result from SCC drivers shown in Table 2.4. This cooperation ensures a more efficient management of the SCC drivers. On the other hand, managers have to provide and evaluate relevant information like bottlenecks in capacity or delivery situation for coming to a decision. So it is not only the information exchange itself that supports dealing with SCC, but the frequency and the content of it. The following hypothesis is proposed:

Hypothesis 3: Group-based and cross-functional targets from purchasing, sales, production, product development and logistics reduce SCC.

2.6 Conclusion

The results of the research provide a general overview of SCC management initiatives that can be utilised to assist decision-makers in formulating strategies to deal with complexity. The solution strategies and supporting tools and techniques that are used to overcome complexity-related problems. The synthesis outlines that when dealing with detailed complexity the companies tend to use strategies to reduce complexity while with dynamic and decision-making complexity they try to manage the complexity and adjust their operations to cope with it. The use of tools and technologies to support complexity management is widely used and recognised (Serdarasan, 2013).

The results are in line with the literature where we observe three generic approaches when dealing with complexity in the supply chain: complexity reduction, complexity management, and complexity prevention (A.T. Kearney, 2004; Bode et al., 2015; Childerhouse et al., 2003; Hoole, 2005; Perona et al., 2004; Serdarasan, 2009, 2013; Sivadasan et al., 2004; Wildemann, 2000; Wu et al., 2007). The common approach is to manage the necessary complexity in the system, and finally to prevent any additional unnecessary complexity. The necessary complexity can be defined as what the customer/market is willing to pay for and what would provide a significant competitive advantage for the added complexity and unnecessary complexity as what brings no additional benefits to the company/supply chain but involves additional costs. In the long run, when dealing with a complex system all types of approaches should be considered to maintain the balance and the entirety of the system. Grounded in the good practices of complexity management in the supply chain, a complexity management system can be broadly outlined as a series of actions. Starting with identification of the current drivers and level of complexity in the supply chain, next step is determining strategies for complexity reduction/management succeeded by evaluation of these strategies based on the opportunities for improvement and determination of the desired level of complexity. Once activities based on the selected strategies are executed, the results should be assessed and fed back to the cycle to evaluate the overall success of the complexity management system.

This research presents in Section 2.2 the current status of SCC in literature. It offers a clear and succinct definition and develops some helpful guidance for the management of SCC. Additionally, a detailed case study is conducted to extend the understanding of SCC from a managerial perspective. By conducting in-depth interviews with top managers from different functions it is elaborated which types of complexity drivers are challenging manufacturers. New services like preventive or predictive maintenance represent new business models. Although, lots of data is available, the decision which strategy should be preferred is quite complex in terms of costs. Another aspect discussed in the context of SCC is the role of product variety. A product analysis shows the number of available product part numbers in relation to their sales volume. The product analysis offers different causal aspects for an increase of complexity. Finally, hypotheses are proposed of how to manage internal and external SCC.

It is clear that managers are faced by an increase of SCC. In this context, the question emerges concerning how to deal with it when customer requirements are changing quickly or market conditions require adjustments of the supply chain. These questions must be thoroughly answered if companies want to survive in a highly competitive marketplace. Therefore, it is necessary to discuss different drivers of SCC as well as different strategies of SCC management. The present research emphasises the necessity of the integration of complexity management into SCM and shows insights into the situation of a manufacturer regarding SCC issues. It discusses the deficits of SCM and proposes recommendations of how to deal with SCC. The complexity of the supply chain relates to numerousness, variety and interrelationships of its elements as well as the internal and external dynamics which influence this system. These parameters refer to the objects of SCC which are processes, products, information, systems, supply chain partners. In order to cope with drivers of SCC, different strategies of SCM are discussed so that clear strategies are derived for mastering complexity. There are four different strategies which are accepting, controlling, reducing, and avoiding. Each strategy is defined, discussed and indicates the importance for strategic implication of SCM. SCC plays an important role within SCM as it ensures a high supply chain performance. The strategies are not only discussed theoretically, but also enriched by operational and practical evidence. However, future projects are necessary to extend and test this work. Additionally, quantitative research is needed to evaluate the relations between the presented findings of SCC.

In total, this case study provides deep insight into a global acting company with a complex supply chain. Despite already implemented standardisations of processes or product ranges as well as of information exchange, it is surprising that the company is still faced by SCC problems. Especially the newly-detected SCC drivers require additional activities to cope with these challenges. These drivers lead to a redesign of information exchange with group-based targets accompanied by different information management and new tools. Another noticeable aspect is that the new SCC drivers are not deterministic, but dynamic. As it is known from literature, dynamic SCC drivers are more difficult to cope with as they are less predictable. This means that additional capacities are required to work on SCC measures like provision of IT infrastructure for evaluating big data information. Therefore, managers cannot rely on known methodologies like standardisation, for example. They always have to look into the

SCC drivers and decide on focused activities. These activities will be a trade-off between the contribution for handling a SCC driver and the input which may cause further SCC.

Regarding the management of SCC, attributes like numerousness, organisation and product design play an important role. It means also that cooperation in the upstream and downstream supply chain may be intensified to achieve common benefits in terms of cost savings. Section 3 discusses the different attributes of SCM based on the triple-A research (Lee, 2004). The different attributes which are called supply chain agility, supply chain adaptability and supply chain alignment are further explored in another case study which includes in-depth interviews from suppliers, manufacturers and customers. This is new in researching SCC that not only internal, but also external supply chain partners are included. Another focus of the following section is the supply chain attribute and its effect on KPIs. With the link of the supply chain attribute to KPIs, a basis is given for measuring supply chain requirements.

The study explored SCC using a company based single case study. A potential weakness of this study is the limitation of generalisation. The major limitation of this study is the confinement of validation to one case, and there are also challenges in evolving a quantifiable composite measure for SCC. This can be addressed in further work, where detailed case study analyses for various industries can be carried out. Nevertheless, the results can be generalised at least within the machine construction industry and future research may be needed to explore generalizability to other industries.

3 Supply Chain Agility:

A Case Study in the Drive and Control Industry²

3.1 Introduction

Even if companies are faced by an increase of SCC, it is very important for their competitive business performance that their supply chains are agile in the sense of being responsive to the market. The agility of an organisation depends on the agility of its supply chain. Supply chain agility can be achieved by other abilities within the organisation, mainly supply chain flexibility and IT integration. Lots of processes are behind these abilities which again lead to an increase of SCC (Swafford et al., 2008). Lee (2004) explored in his studies several leading companies that focused on designing adequate supply chains with the target to deliver goods and services to consumers as quickly and inexpensively as possible. Those firms invested in state-of-the-art technologies, and when the expected success did not turn out, highly talented experts were hired to push supply chain performance. Many companies also teamed up to streamline processes, lay down technical standards, and invest in infrastructure they could share. All of those companies and initiatives persistently aimed at greater speed and cost-effectiveness – the popular grails of SCM. According to Lee's (2004) research, top-performing supply chains are characterised by three very different qualities. First, successful supply chains are agile. They react quickly to sudden changes in demand or supply. Second, they adapt over time as market structures and strategies emerge. Third, they align the interests of all parties in the supply network so that companies optimise the chain's performance while maximising their interests. Only supply chains that are agile, adaptable, and aligned provide companies with sustainable competitive advantage. Based on this research results, literature (Dubey et al., 2017; Chan et al., 2017; Yusuf et al., 2014) is extended by exploring these supply chain qualities in the machine construction industry with this research. Contrary to the aforementioned firms out of the consumer goods industry, this paper is focused on the machine construction industry. In detail, this research investigates which supply chain qualities have to be fulfilled from the perspective of an OEM when SCC is continuously increasing. It includes not only

² Malina, S., Spinler, S., 2018. Supply Chain Agility: A Case Study in the Drive and Control Industry. Unpublished manuscript

internal aspects from the manufacturer, but also insights from upstream as well as downstream supply chain partners. Further, it is explored how the qualities effect key performance indicators.

An emerging body of research in SCM pertains to the development of flexibility and agility to cope with the challenges of more dynamic and complex marketplaces. In recent years, in addition to increasing levels of competitive pressure, business environments have also been characterised by growing levels of turbulence and unpredictability. Thus it has been stressed that organisations must strategically develop agility to provide superior value as well as to manage disruption risks and ensure uninterrupted service to customers (Christopher, 2000; Christopher and Towill, 2001; Zhang et al., 2002, 2003; Chopra and Sodhi, 2004; Kleindorfer and Saad, 2005; Swafford et al., 2006).

Lee (2004) highlights that companies that aim to achieve a sustainable competitive advantage need an agile, adaptable and aligned supply chain. Others argue that agility is conceptually distinct and different from flexibility, but that flexibility is still a key characteristic of agility (Christopher, 2000). While both concepts refer to the ability to change, Swafford et al. (2006) characterise the flexibility-agility association as a competence-capability relationship. According to strategy literature, capabilities are externally focused, while competencies are internally focused, and capabilities are derived from competencies (Prahalad and Hamel, 1990; Teece et al., 1997; Zhang et al., 2002, 2003); thus, supply chain agility can be considered as an externally focused capability, while flexibility is an internally focused competency and its antecedent. As Swafford et al. (2006) also highlight, a system can be flexible without being agile, but an agile system is always flexible. Narasimhan et al. (2006) define agility as “the ability to efficiently change operating states in response to uncertain and changing market conditions. Agility involves many types of flexibility, and it includes the capability to do unplanned new activities in response to unforeseen shifts in market demands or unique customer request.” This case study offers the possibility to explore supply chain agility in detail for the manufacturer, but also for suppliers and customers, i.e. upstream and downstream supply chain. This differentiation is new in literature and provides an academic contribution to the ongoing discussion.

This paper is organised as follows: Section 3.2 presents an overview of literature pertaining to the triple-A, including the research questions explored in this study. Section 3.3 explains the case study methodology as well as sample description, data collection, and analytical methodologies. Section 3.4 presents the research findings including a discussion of the results.

This study contributes to the topical research in the emerging field of supply chain agility, supply chain adaptability, and supply chain alignment by providing supporting case study findings. This study increases the managerial understanding of advanced SCM.

3.2 Literature Review

3.2.1 Supply Chain Agility (SCAg)

In an international environment, the supply chain often is the part of a firm which is most severely affected by changes in the manufacturing or political environment. The firm's international supply chain frequently limits performance due to many traits usually associated with agility. For example, it may be difficult to adjust the structure or geographical setup of a supply chain to react to changes if the firm has plants on more than one continent. In such cases, supply chain agility may quickly become the limiting factor in a firm's overall agility (Prater et al., 2001).

Supply chain agility can be defined as the ability to respond rapidly to unpredictable changes in demand or supply (Lee, 2004; Swafford et al., 2006). Many organisations are at risk because their response times to demand changes or supply disruptions are too slow. Agility has many dimensions and it concerns both networks and individual firms. Indeed, a key to agile response is the presence of agile partners both upstream and downstream. Researchers (Gligor et al., 2013; Gligor et al., 2014; Eckstein et al., 2015) define supply chain agility as the ability of the firm to change tactics and activities within its supply chain to respond to market opportunities, environmental changes as well as to threats. Further literature discusses flexibility as a construct with dimensions including adaptability, alignment and agility (Stevenson et al., 2007, 2009), but this has not discussed the combined attributes of agility, adaptability and alignment.

Agility has also been defined, in the context of structuring leanness and agility, as “the ability to efficiently change operating states in response to unforeseen shifts in market demands or unique customer request” (Narasimhan et al., 2006).

Aside from flexibility, other potential antecedents of agility include the role of internal integration, involving cross-functional alignment, and external integration with key customers and suppliers (Zhang et al., 2002, 2003; Swafford et al., 2006). These authors suggest that internal and external integration are also necessary to ensure connected and coordinated responses to unforeseen changes to create an agile supply chain.

Braunscheidel et al. (2009) analyse the organisational antecedents of a firm’s supply chain agility. This and other studies have shown that organisational culture has a significant impact on operational decisions, such as the adoption of advanced manufacturing technology (Zammuto and O’Connor, 1992; Mc Dermott and Stock, 1999), cellular manufacturing in small businesses (Yauch and Steudel, 2002) and time-based manufacturing practices (Nahm et al., 2004).

Christopher et al. (2004) discuss *visibility* and *velocity* as primary antecedents of supply chain agility. Visibility implies a clear view of upstream and downstream inventories, demand and supply conditions, and production and purchasing schedules. It also implies internal visibility – that is, clear rules and structures of communication and agreement on “one set of numbers”. Visibility is distorted by the presence of the bullwhip effect (Lee et al., 1997), which can magnify small changes in marketplace demand as it moves back up the supply chain. Velocity, as a second antecedent, is defined as distance over time. Hence to increase velocity, a firm must reduce the total time it takes to move products and materials from one end of the supply chain to the other. End-to-end pipeline time – as it relates to agility – can be measured as the through-put-time from when the focal firm places orders with its first-tier suppliers to when it delivers to its customers. It is not only velocity that is important in the creation of agile supply chains, but acceleration. In other words: how rapidly can the supply chain react to changes in demand, upwards or downwards?

Prater et al. (2001) argue that firms should focus on key aspects of supply chain agility and not strive to comply totally with a theoretical ideal of agility. Moreover, even if a very high degree of supply chain agility is called for, the complexity inherent in the

organisation of many international supply chains may make the realisation of complete agility impossible. In this research supply chain agility is defined as the capability to adjust the supply chain short-term to maintain or achieve competitive advantage.

3.2.2 Supply Chain Adaptability (SCAd)

Lee (2004) defines supply chain adaptability as the adjustment of the supply chain design to accommodate market changes. He recommends creating different supply chains for different product lines, to optimise capabilities for each. For example, with highly customised low-volume products, companies should select vendors close to the main markets. For standard, high-volume products, contract manufacturers in low-cost countries are preferable because intermediaries can support the company in finding reliable vendors in unfamiliar parts of the world. Flexibility is increased when different products use the same components and production processes. Adaptable supply chains evolve over time as economic progress, political shifts, demographic shifts, demographic trends, and technological advances reshape markets. Ivanov et al. (2010) emphasise the different structures found in supply chains, including business processes and structures focusing technology, organisation, technique, topology, information and finance. All of these structures are interrelated and variable in their dynamics. Especially in adaptive supply chains with highly variable dynamics, it is critical to achieve structural coverage, responsiveness and flexibility as well as to avoid structural incoherency and non-consistency through supply chain planning and operations. The adaptation of one structure causes changes in the other related structures. To ensure a high responsiveness level, the supply chain plans must be formed extremely quickly, but must also be robust (Ivanov et al., 2010). Ketchen et al., (2007) define supply chain adaptability as the willingness to adjust supply chains where necessary, without ties to legacy issues or the way the chain has been operated previously. Stevenson et al. (2007) argue that supply chain adaptability is the property of a supply chain which allows the partners to deal with the dynamics associated with supply chain. Thus, it becomes very important to develop and execute supply chain plans in relation to all of the structures involved. This can be realised if first different SC structures are considered simultaneously and second the execution dynamics in all of the structures can be

reflected to create mutual feedback between SC plans and operations. In this research supply chain adaptability is defined as capability to adjust the supply chain mid-term to achieve competitive advantage.

3.2.3 Supply Chain Alignment (SCAI)

Lee (2004) defines supply chain alignment as the establishment of incentives for supply chain partners to improve the performance of the entire chain. All partners need equal access to forecasts, sales data and plans. To avoid conflicts, the roles and responsibilities of each supply chain partner must be clarified. By defining partnership terms, the risks, costs and rewards of improving up- and downstream supply chain performance are shared. The incentives are aligned so that players maximise overall supply chain performance while also maximising their returns from the partnership. Lee (2004) suggests that all supply chain partners' incentives and disincentives, e.g. penalties for late deliveries or cost savings through redundant checks of incoming goods, should be transparent. For the supply chain as a whole to experience a benefit, incentives must be organised in such a way that all partners are aligned – for example, by designing contracts so that partners share risks, expenses and benefits in equal parts. After cutting costs across certain supply chains, Wal-Mart executives split the savings equally between their firm, the supplier (Procter&Gamble) and the customer (Croxtton et al., 2001). Alignment of information is also vital – participants must have access to needed data on flows and forecasts to fulfil their responsibilities (Ketchen et al., 2007). Whitten et al. (2012) argue that from a strategic perspective, business functions like sales, manufacturing, purchasing and logistics must be aligned externally and internally throughout the complete supply chain to achieve competitive advantage. In this research supply chain alignment is defined as the capability to shape the supply chain by involving internal and external supply chain partners so that risks, costs and benefits can be shared.

3.2.4 Research Motivation

Several researchers have noted a need for more information regarding what aspects of agility should a firm control to reduce the complexity of their supply chain (Prater et al., 2001; Braunscheidel et al., 2009). Others suggest that case and field research could generate knowledge revealing the impact of these supply chain qualities on a firm's performance (Lee, 2004; Yusuf et al., 2014; Dubey et al., 2017). At the same time, there is a need to identify performance measures that can be used to evaluate the success of these characteristics across the supply chain. As supply chains will compete with supply chains in the future, companies must understand that flexible supply chains will outreach those that are less agile (Duclos et al., 2003; Dubey et al., 2017). Literature (Barratt et al., 2007; Johnson, 2003) states that ideally manufacturers remain competitive by increasing SCAG without increasing costs, but they do not increase SCC. This means that manufacturers shall only provide a level of complexity that customers are prepared to pay. As complexity is inherent to uncertainty, an effective method to manage it is to adapt the supply chain. SCAd adjusts the SC design to response to market changes (Lee, 2004).

Gunasekaran et al. (2008) define SCM as *the coordination of resources and the optimisation of activities across the value chain to obtain competitive advantages*. Lee (2004) discusses how the triple-A supply chain can produce a competitive advantage, but does not explore how SCAG, SCAd and SCAl are reflected in a firm's performance.

Kaplan and Norton (2001) introduced the balanced scorecard arguing that an exclusive reliance on financial measures in a management system is not sufficient. Financial measures are lag indicators that reflect on the outcomes from past activities. Exclusive reliance on financial indicators could support behaviour that sacrifices long-term value creation for short-term performance (Porter, 1995). The balanced scorecard approach keeps measures of financial performance – lagging outcome indicators – but replenishes these with measures on the drivers, the lead indicators, of future financial performance. This limited approach has been challenged, with the introduction of the concept of key performance indicators for non-financial results (Beatham et al., 2004).

The difference between strategic and operative KPIs is often neglected. Strategic KPIs are relevant for the long-term performance, e.g. development of EBIT (earnings before

income tax). Therefore, the collection of data is not necessary in such short frequencies as it is for operative KPIs (e.g. through-put times in production processes). It is recommended that operative KPIs are collected and controlled in real time. Operative KPIs help to identify strategic challenges on time and take the opportunity to start activities appropriately. The key is to implement strategic and operative KPIs correctly so that they are in accordance with the company's strategy and are relevant for their purpose (Parmenter, 2015; Weber, 2012).

Literature (Blome et al., 2014; Dubey et al., 2017; Gunasekaran et al., 2017; Fosso Wamba et al., 2017; Raue et al., 2013) argues that research still needs to be improved in the emerging field of agility, adaptability and alignment. Based on the literature review, the following research questions arise and are explored in this case study:

- (1) Which operative and strategic KPIs measure supply chain agility, adaptability and alignment?

The first question is answered by asking managers which KPIs are installed and monitored for deriving measures on the three supply chain qualities. Yusuf et al. (2014) offer some insights into this topic for the oil and gas industry based on strategic KPIs. An extension to other industries and also operational KPIs is still missing.

- (2) What interdependencies exist among supply chain agility, adaptability and alignment?

The second research question analyses if the three qualities can be treated by supply chain managers individually or if there are interdependencies which may offer competitive advantages. Literature (Lee, 2004; Dubey et al., 2015) offer some general findings e.g. for the humanitarian sector, although answers are still missing for the machine construction industry, especially under the involvement of the upstream and downstream industry.

- (3) How can optimal levels of supply chain agility, adaptability and alignment be achieved?

The investigation to answer this question offers various measures which managers can implement to improve a company's level of supply chain agility, adaptability and alignment. However, an increase of one quality may also lead to an increase of SCC. Blome et al. (2014) discuss this question focusing on supply chain flexibility. However, literature regarding this question needs to be extended for the aforementioned qualities.

As these research questions are not answered in existing literature, a case study is conducted to answer these questions. Another contribution of this research is that data is not only collected from internal employees of a manufacturer, but also from external supply chain partners – i.e. customers as well as suppliers – so that both upstream as well as downstream supply chain can be covered.

3.3 Research Methodology

3.3.1 Case Study Methodology

The case study method was selected because it offers an appropriate approach for exploring the supply chain qualities of agility, adaptability and alignment under consideration of the novel character of the research (Manuj and Mentzer, 2008). The strengths of case study research include the likelihood of generating novel theory, the possibility of direct testing and resulting empirical validity (Eisenhardt, 1989; Eisenhardt et al., 2007). Further advantages include relevance, understanding and exploratory depth (Meredith, 1998). Boyer and Swink (2008) also suggest that case studies provide richness and first-hand observations in a natural setting, thus providing a foundation for further review. Drawbacks to case study research include a lack of rigour, a low possibility for scientific generalisation, and high time and cost requirements (Yin, 2014). Eisenhardt (1989) identifies a risk of overly complex theories lacking parsimony. Additionally, Boyer and Swink (2008) identify a risk of bias on the part of the researcher. For Yin (2014), case study research is most appropriate when 'how' or 'why' questions are being asked and when evaluating contemporary, rather than historical, events. Meredith (1998) states that case studies are best used to generate and extend theory. In the early stages of theory building, the researcher should be in close contact with the environment being studied (Handfield and Melynk, 1998). Case studies are

used to investigate small samples analysing a large number of variables to identify new empirical relationships for an in-depth understanding of the complex external world (Wacker, 1998).

Case study methodology is thus appropriate and applicable for explorative theory development, such as the investigations in the present paper. To avoid the shortcomings listed above and ensure the fulfilment of the aforementioned criteria, we will follow the clearly defined process developed by Stuart et al. (2002). This process comprises five stages: (1) define the research question, (2) develop the instrument, (3) gather data, (4) analyse data and (5) disseminate the results.

3.3.2. Sample Description

After the definition of research questions in section 3.2.4, the researchers developed the research method and selected the company for study. A theoretical sampling approach (Glaser and Strauss, 2017) was used by selecting a company that could provide relevant data to gain a deeper understanding of the research questions. For this purpose, the company selected would need to experience challenges in a competitive industry but demonstrate strong operational and financial performance. The company should additionally provide a heterogeneous structure and sufficient size to enable the comparison of company divisions as sub-case studies. The case company, which is selected for this study operates in the highly competitive machine construction and automotive industry. For confidentiality reasons, the name of the company has been disguised. Characteristics of this industry include customised low-volume products, but also series business as well as project business with a high level of product variety and demand for intense customer service. Customers in this industry tend to make purchasing decisions based on price and brand awareness and show increasing interest in short-term product availability. The market is characterised by high quality requirements and cost pressure driven by upcoming private competitors in Asia, increasing customer requirements and thus high expenditures in R&D. The supply chain of the company under study is structured in a global, regional and local organisation in North America (NA), Europe (EU) and Asia-Pacific (AP).

3.3.3 Data Collection and Analysis

In order to gather data to explore the research questions, structured interviews were conducted. Overall, nineteen semi-structured interviews were held. This included interviews with fifteen middle and senior managers from various business units. Additionally, two customers from Germany and Italy as well as two suppliers from Germany were asked to provide information to explore the up- and downstream supply chain (Table 3.1). Both the suppliers and customers have maintained a business relationship with the manufacturer for more than 8 years. All interviewees selected were on a sufficiently high managerial level to allow them to contribute meaningful answers to the research questions, based on their responsibility and experience.

The content of the interviews was based on emerging theory (Glaser, 1978), i.e. upcoming relevant questions were explored and discussed until no further new information resulted from the last interview as compared to the previous ones and, therefore, saturation was achieved. The interviewees included employees from the logistics controlling department at the corporate headquarters who were working on the development of logistic key performance indicators. They also included senior logistics managers responsible for worldwide logistics activities to remain competitive, i.e. to achieve high customer satisfaction through high delivery performance or reduce logistics costs by improving costs for inventories. In order to increase internal as well as external validity, senior managers from different business units, regions and functions were interviewed. This interview process included managers from corporate, business units and plants from different locations and functions such as logistics, purchasing, sales and R&D. The supply chains in the regions of NA, EU and AP were explored by interviewing the head of regional logistics.

Table 3.1: Overview of Interviewees

	Function	Organization/ Location	Responsibility	Seniority/ Business relationship
Manufacturer	Logistics Manager	Corporate	Standardization of logistics projects worldwide	9 years
	Logistics Manager	Corporate	Head of supply chain innovation activities	5 years
	Logistics Manager	Corporate	Standardization of logistics projects worldwide	15 years
	Logistics Controller	Corporate	Logistics Controlling, Target Development, Reporting	2 years
	Logistics Manager	Business Unit	Target Responsibility for plants, implementation of logistics standards	1 year
	Logistics Manager	Business Unit	Target Responsibility for plants, implementation of logistics standards	4 years
	Logistics Manager	Business Unit	Target Responsibility for plants, implementation of logistics standards	10 years
	Logistics Manager	Plant	Plant responsibility for material and information processes	4 years
	Logistics Manager	Plant	Plant responsibility for material and information processes	7 years
	Head of Purchasing	Corporate	Corporate responsibility for purchasing activities and suppliers	12 years
	Product Development	Business Unit	Product responsibility for defined product groups	4 years
	Sales Director	Country Unit	Sales Responsibility of a European country unit	18 years
	Logistics Director	Corporate	Region America	5 years
	Logistics Director	Corporate	Region Europe	3 years
Logistics Director	Corporate	Region Asia	4 years	
Supplier	Sales Manager	Germany	Key-Account-Manager	8 years
	Sales Manager	Germany	Key-Account-Manager	5 years
Customer	Purchasing Director	Italy	Price negotiations and delivery conditions	5 years
	Purchasing Director	Germany	Price negotiations and delivery conditions	6 years

Validity requirements are fulfilled by using multiple sources of evidence, obtained by interviewing managers from different organisation units, regions and functions that vary significantly from each other (Glaser and Strauss, 2017). The interviews were semi-structured and lasted approximately 1.5 hours. This structured approach created internal validity by ensuring comparability between interviews. To check the accuracy of the verbal responses, the data was triangulated (Stuart et al., 2002) by examining controlling reports and meeting minutes. This additional data helped to support or correct the interviewees' comments, thereby avoiding reliance on individual subjective observation. Each interview started with an overview of the research project. The semi-structured questionnaire focused on the managers' understanding of SCAG, SCAd and SCAl and the impact of the qualities on the company. Finally, the interdependency of the three qualities was discussed.

The interviews were documented in written form and evaluated and categorised using Microsoft Excel. The grounded-theory methodology of systematic organisation and constant comparison of data within and between interviews was followed by using open, axial, selective coding (Glaser and Strauss, 2017). In open coding, the data under analysis was coded (e.g. slow response time or poor quality in planning). In axial coding, a link between SCAG, SCAd and SCAl was developed. In selective coding, the core

code (e.g. SCAG) was identified and explored to determine whether commonalities through function or region could be discovered. Internal validity is pursued during the data analysis phase through the use of pattern-matching and explanation-building. With findings that support or are consistent with existing theory, external validity is supported (Yin, 2014). In order to ensure internal validity, the answers were reviewed by placing different patterns on the results: the results were analysed by work experience, region, level, function and department (Stuart et al., 2002). Following Gibbert et al. (2008), the following criteria were applied to ensure rigour in the data collection and analysis: internal validity, construct validity, external validity and reliability (Yin, 2014). Relevant sources were defined in advance and questions were formulated prior to interviews and observation. This helped to ensure that data was correct and appropriately organised, while minimising any social desirability bias on the part of the researcher (Fisher, 1993). The minimisation of social desirability bias reduces systematic errors resulting from the desire of respondents to avoid embarrassment and project a favourable image to others (Fisher, 1993).

3.4 Findings

3.4.1 Design of Performance Indicators

While SCAG and SCAd reflect the flexibility and capability of the SC itself, SCAl is seen by the managers as the willingness to synchronise the supply chain with suppliers and customers. One logistics director argued that SCAl should ideally eliminate the bullwhip effect. This can be achieved when relevant information on demand developments is made transparent, and when common targets are developed with benefits for all parties including both internal and external supply chain partners. The aim is to achieve cost reductions of inventories and improved order fulfilment towards the customers.

Again, all managers confirmed that SCAl influences their business significantly. Managers from the upstream and downstream supply chain argue that common target setting is beneficial for all partners in the supply chain and the measures and activities from SCAG and SCAd are a cornerstone for the definition of common targets. SCAl

requires the enforced integration of suppliers and customers in terms of demand development, sourcing locations and product development. Especially while managers see the trend that customers move to low-cost countries, products should be available close to the place of consumption. For cost reasons (transportation, inventory) customers source their goods locally, so that local suppliers are preferred. This “local for local” approach may result in lower logistics costs, but it also results in an increase in SC complexity due to an increase in the number of suppliers and differences in product quality. To cope with this risk, the company under study offers consulting, free of charge, to preferred suppliers to help them to understand the requirements of the company. Integrating the suppliers in this way improves awareness of the manufacturer’s targets, e.g. in terms of delivery performance or logistic costs.

Looking towards the customers – the upstream SC – the company under study tries to use forecasts to manage order fulfilment under optimal cost development. When customers benefit from shorter delivery times without price increases due to reduced warehouse costs, the willingness to provide and exchange appropriate information increases. The interviewees agree that, for an aligned SC, all SC partners need clear rules and synchronised processes with appropriate IT support. “We see many benefits for all SC partners with an aligned SC. Due to different interests it will be difficult to summarize the target in the short term, but in the long term, it will support our strategy and improve competitiveness.” The resource dependence perspective proposes that *organisational success and ultimately survival occur by maximising power* (Pfeffer, 1981) through acquiring rare and cost-intense resources (Pfeffer et al., 1978). Pfeffer et al. (1981) state that with the relevance of the resource, firms should aim an increase of vertical coordination. The resource-based view (Penrose, 1959; Rumelt, 1984; Wernerfelt, 1984) reviews these propositions and argues that strategic resources in an industry may be different across firms. As these resources may not be transferrable, the resource heterogeneity may remain (Barney, 1991).

Firms should increase coordination with other members of the supply chain; for example, by acquiring access to strategic supplier technologies and knowledge, forming supplier partnerships and strategic alliances (Arminas, 2004), developing joint ventures (Ellram, 1992), or even purchasing sources of supply (Webster, 1992). Especially under uncertainty (Pfeffer and Salancik, 1978), which is caused by dynamism and complexity

(Duncan, 1972) in the supply chain environment, the relation between resource dependence and vertical coordination becomes even more important.

Literature (Soosay et al., 2008; Swink, 2006; Barratt, 2004) emphasises that the key to a successful supply chain is achieving enhanced inter-organisational relationships that can improve innovation. Relevant types of SC integration are either vertical or horizontal integration. While horizontal integration focuses on SC activities on the same level of the supply chain (Barratt, 2004), vertical integration concentrates on SC activities on different levels of the supply chain (Caputo et al., 1996). Barratt (2004) argues that horizontal integration results in reduced logistics costs or advanced procurement terms through group purchasing power. Caputo et al. (1996) see the advantage of vertical integration in the improvement of better material and information flows. Traditionally, the field of strategic management has analysed an organisation's external opportunities and threats (Ansoff, 1965; Porter, 1980, 1985) under the assumption that *internal organisational resources are homogeneous and any existing resource heterogeneity within an industry will be short-lived* (Porter, 1980).

With this case study, it is explored which KPIs are used as indicators for activities on SCAG, SCAD or SCAL. The manufacturer uses its standard strategic and operative KPIs for further definition and implementation of activities on a more agile, adaptable and aligned supply chain. Based on the interview results a remarkable impact for allocating the KPIs to SCAG, SCAD and SCAL is given by the time aspect which is perceived by the individual qualities. While SCAG represents short-term activities, the managers argued that the information if SC activities are agile or not, is mainly received by operational KPIs. The situation looks different regarding the measurement of SCAD. Referring to the interviews again, SCAD represents mid-term activities. Here managers mentioned that they receive feedback from tactical KPIs, e.g. customer surveys or spontaneous individual feedback. The head of purchasing gave the following example: "We offer regularly free of charge trainings to our suppliers so that they do better understand our needs. They get trained of how our forecasts are to be understood so that they can provide material accordingly. This helps us to avoid any material bottlenecks, but also to save inventory costs. On the other hand, we learn which information is needed by the supplier. In this case, we can adapt our supply chain so that a win-win situation for the supplier and for us occurs". Finally, SCAL is perceived as a long-term

supply chain activity. As expected, the interviews offer evidence that the alignment of the supply chain is included in strategic KPIs like sales, market share or profit. Activities for an aligned supply chain entail intense cooperation towards customers and suppliers with mutual confidence and targets. A logistics manager says: “Only when the partnership enjoys a high level of confidence, the partners are prepared to provide and exchange data so that costs can be saved or the lead-time performance can be improved throughout the complete supply chain”. In summary a correlation between the duration of the SC activity and the type of KPI could be observed. Table 3.2 provides an overview of the assignment of KPIs for SCAG, SCAd and SCAl from the perspective of logistics and their impact on relevant KPIs.

Table 3.2: Overview of KPI assignment for SCAG, SCAd and SCAl

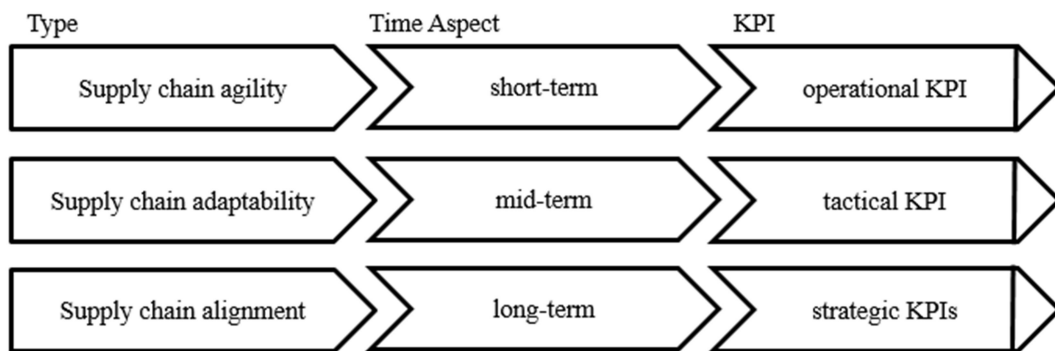

KPI Overview

Operational	Tactical	Strategic
<ul style="list-style-type: none"> Logistics costs (% of turnover) Total coverage time (sales vs. inventory) Fulfilment of lead-time Delivery performance of suppliers Delivery performance to customers Through-put times in production Through-put times in logistics Level of inventory Administration costs Production costs 	<ul style="list-style-type: none"> Customer satisfaction survey Individual and spontaneous feedback 	<ul style="list-style-type: none"> Sales Market share Earnings before income tax (EBIT) <p>Balanced scorecard approach:</p> <ul style="list-style-type: none"> Aligning external partners Managing the alignment process Total strategic alignment Alignment as source of economic value

Regarding operational KPIs for measuring supply chain agility, the following KPIs are monitored: manufacturing costs, production costs, logistics costs, delivery performance

and inventories. In terms of supply chain adaptability the manufacturer in this case study uses feedback from customer satisfaction surveys or further individual or spontaneous feedback. Strategic KPIs like sales, earnings before income tax (EBIT) and market share are used to monitor the development of supply chain alignment. One of the most complicated decision-making problems for managers is the evaluation of the supply chain performance (Shafiee et al., 2014). Although vast studies have been conducted on supply chain efficiency evaluation via a balanced scorecard approach (BSC), these studies do not focus on the relationships between the four perspectives of BSC approach (Shafiee et al., 2014). These four perspectives include a financial perspective, a customer perspective, an innovation and learning perspective and finally an internal process perspective (Kaplan et al., 2001). With the implementation of group-based, especially cross-functional targets, an improvement in KPIs could be monitored in this case study. Traditional performance measures focused only on financial metrics in the past (Kaplan et al., 1992; Hoque, 2014). Researchers (Bromwich et al., 1989; McNair et al., 1990) prior to Kaplan and Norton criticised such measures for encouraging managers to focus on short-term financial results while sacrificing long-term perspectives. These and others (Lynch et al., 1991) promoted the idea that additionally non-financial measures like on-time deliveries, process cost reduction, quality, cycle time and product complexity would be of benefit for organisations in the longer run (Chenhall et al., 2007). The idea of linking measures to strategy is also not unique to the balanced scorecard. Grady (1991) stated that the strategic objective of a company should be broken down into critical success factors and critical actions. Hoque (2014) presents in his research approaches in terms of alignment, e.g. aligning external partners or processes. Thus, it is recommended to managers also to apply balanced scorecard aspects to push SCAl.

3.4.2 Interdependence of SCAg, SCAd and SCAl

This paper investigates the interdependence of SCAg, SCAd and SCAl. Kembro et al. (2015) argue in their research that connectedness of inter-firm relations implies a certain type and intensity of interdependence among supply chain actors. Notably due to Thompson's (1967) work in organisation theory, three main types of interdependence can be identified:

Pooled interdependence represents two activities without direct links that share a common resource and contribute together to a system output: *each part renders a discrete contribution to the whole and each is supported by the whole*. **Serial interdependence** occurs through direct links between activities where the input of one part is directly dependent on output from another. **Reciprocal interdependencies** depict mutual exchange of inputs and outputs with *each unit posing contingency for the other*. Thompson (1967) states that the type of interdependence generates implications for organisational communication and coordination, moving from pooled to serial to reciprocal interdependencies between units, communication requirements and coordination of cost increase. Skipper et al. (2008) extended interdependence theory in the study of inter-organisational exchange relationships and particularly the combination of serial, pooled and reciprocal interdependencies can be useful to understand the mechanics of supply chains as networks of exchange relationships (Kembro et al., 2015). According to Dubois et al. (2004) *the supply chain concept relies strongly on the notion that there is sequential interdependence among activities which therefore need coordination* with focus on adjusting and aligning such activities to increase output, reduce costs or increase the service level of the system. Additionally, pooled interdependencies manifest themselves in supply chains where any organisation represents a range of resources and activities that need to be efficiently integrated despite the fact that this organisation may be a member of several different supply chains. In other words, many supply chains compete for the same resource whereas each supply chain partner may have different interests (Kembro et al., 2015). It seems that the potential of interdependence theory for studying inter-organisational information sharing in supply chains has been underplayed (Kembro et al., 2014). It is assumed that when the different types and intensities of interdependence among supply chains are considered, that this can help to better understand not only potential barriers to information sharing in the extended supply chain but also how such information sharing may need to be adapted to the particular context. Danese et al. (2004) state that the characteristics of interdependence between firms and the number of interacting firms are important to consider when selecting coordination mechanisms. Cox (2004) formulates interdependence in the context of high buyer power relative to supplier, and vice versa. In other words, interdependence only exists when both buyers and supplier can exert power to each other. Characteristics that indicate the intensity of

interdependence (e.g. weak or strong) include the number of potential buyers and suppliers, percentage share of total market for supplier, allocation of costs and uniqueness in offerings (Cox, 2004).

Literature (Thompson, 1967; Dubois et al., 2004; Cox, 2004) provides insights of interdependencies of information sharing in a supply chain. Especially when conflicts occur, personal relations and contracts seem important for partners to commonly resolve any issues and together learn how to improve in the future. The direct connection in dyadic supply chain relationships studied indicates either reciprocal or serial interdependence. Based on the aspects explored by Cox (2004) and taking the definition by Dubois et al. (2004), it seems that two supplier relationships exhibit characteristics of strong reciprocal interdependence.

Before the interdependencies of SCAG, SCAd and SCAl are analysed, the three qualities are shortly reviewed. Sharp et al. (1999) define supply chain agility as the ability of a supply chain to quickly respond to changes in market and customer demand, while Ismail and Sharifi (2006) describe it as the capability of the supply chain and its members as a whole to rapidly align the network and its operations to dynamic and turbulent customer requirements. Supply chain adaptability is also necessary for companies to generate capabilities to cope with long-term, fundamental changes like radical advances in technology, structural shifts in key markets and socio-political as well as demographic changes (Eckstein et al., 2015). Further to the definition overview in section 3.2.2, alignment is achieved through inter-organisational relationships that are governed by a combination of formal contracts and relational norms (e.g. trust, confidence) (Cao et al., 2015; Wacker et al., 2016). These frame conditions enable companies in supply chains to align with their changing environments and market requirements and improve performance (Matthews et al., 2017). In this paper it is proposed that supply chain alignment is a process which is underpinned by the dynamic market requirements and the limited resources that a company has. A process perspective is also important because performance objectives and incentives often must be realigned, even long after a contract is agreed (Lee, 2004).

Based on this review, a certain interdependence can be assumed and will be further elaborated in this section. The analysis of the interviews shows that all three qualities refer to changes of the SC design. Activities that are implemented to increase SCAG,

SCAd and SCAI are used as a method to define and achieve overall company targets in both the commercial context in terms of sales or profit as well as in the logical frame in terms of delivery performance or logistic costs. This finding pertains to the overall supply chain including suppliers, manufacturers and customers. Next, an effort was made to differentiate and prioritise these qualities. Figure 3.1 shows a framework depicting the triple-A in SCM under consideration of various criteria such as implementation period, scope or KPI effect.

Figure 3.1: Framework of a triple-A Supply Chain

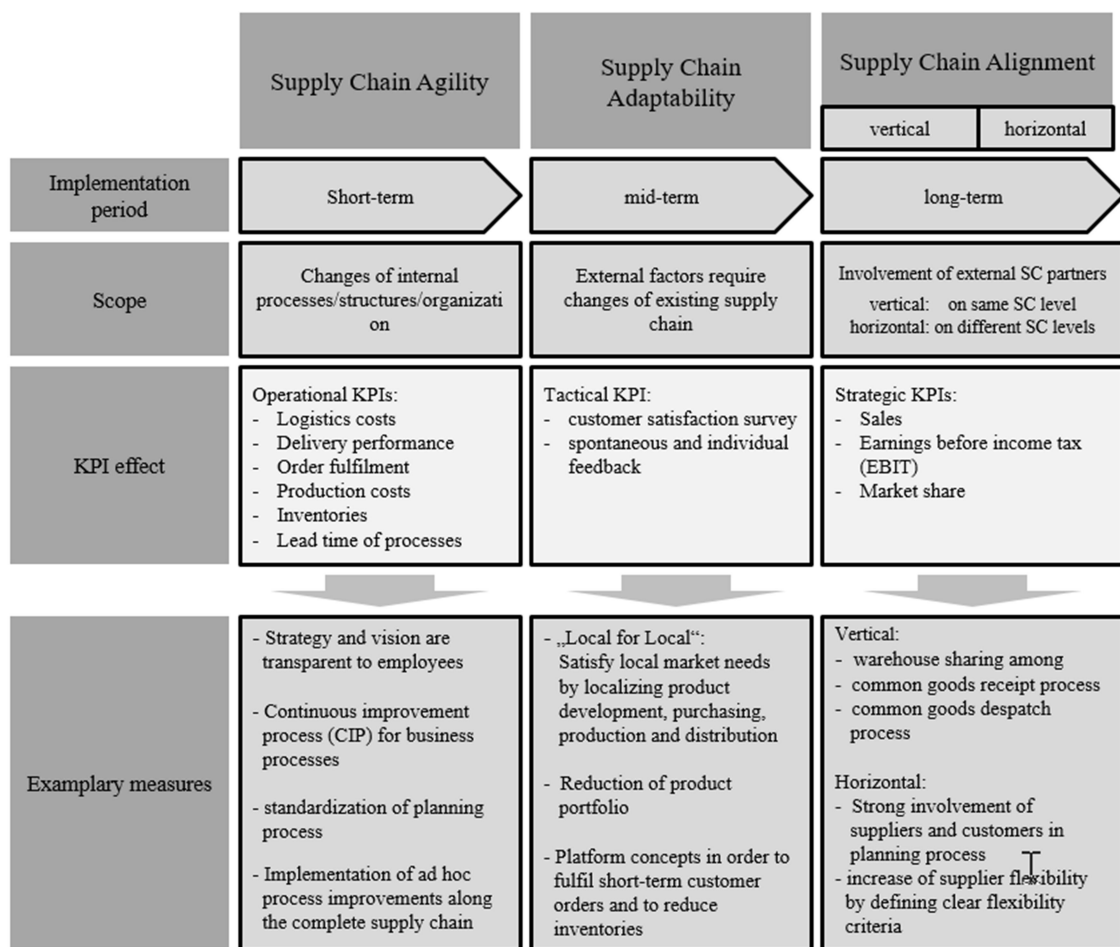

This framework gives a clear picture about different aspects of an agile, adaptable and aligned supply chain. Despite the differentiation, there are also interdependencies among these qualities. A logistics director explained: “In order to remain profitable and fulfil our customers’ requirements, we have to strongly involve our suppliers and customers into our processes. For example, we developed a so-called supplier flex index so that the supplier gets the information what our flexibility expectations are. This helps

both sides to ensure material availability and avoid obsolete stock. However, mutual trust is absolutely necessary when it comes to information exchange.” The framework shows also that SCAl is measured by means of strategic KPIs. This may lead to the assumption that SCAl is of highest priority for managers, although it may take more time and effort until realisation compare to the other qualities. As SCAl involves external SC partners, the common target definition process takes more time, but is considered to have a more sustainable effect on the SC design. This effect is based on common benefits such as cost savings from inventory costs or transportation costs which are shared among the SC partners. Some interviewees emphasised that for a successful aligned supply chain it is very important and necessary that all supply chain partners are willing to share information and thus increase transparency. According to their experience and estimation this cooperation can be expected from customers to fulfil their delivery expectation, but also from suppliers so that they are in the position to provide material accordingly. The managers also highlight that the target or benefit for all parties must be clearly defined and understood, otherwise the information exchange may not be fully supported and may lead to fail the common target. Based on the outcomes of the interviews it is clear that the target of the manufacturer is to achieve an aligned supply chain, because this offers shared costs and mutual benefits, but also risks among all supply chain partners. Regarding SCaG, managers state that activities for a higher level of agility are decided rather spontaneously and regarded as trial. Only if the measurement is of sustainable success, the measurement may be taken up as standard for SC management so that it finally represents an adapted supply chain. A topical example is the current test for dispatching goods from Germany to Asia by train instead of vessel. This means that not each agile SC activity leads to an adapted SC automatically. This may be valid only for sustainable activities, which bring a persistent benefit to the company. Referring to Thompson (1967) it can be assumed that a reciprocal interdependence exists between SCaG and SCAd. When SCAl then enters into the game so that external SC partners are involved, it is obvious that processes among the supply chain partners have to be adapted to exploit benefits. Only if the supply chain is adapted, the alignment of it can commence. Again, a reciprocal interdependence between SCAd and SCAl becomes evident.

In this case study the manufacturer offers customised products of uniquely designed components with individual delivery times, but also serial products which underlie short

delivery times to remain competitive against other manufacturers. For this reason, the manufacturer made changes in its supply chain design by relocating production facilities or by introducing flexible purchase quantities with selected suppliers. Due to the reciprocal type of interdependence, the supply chain had to be adapted in terms of its design on a strategic level to implement business processes as well as to create a shared view of the future and secure business for the next years. With the new supply chain design which entails activities of SCAG, SCAd and SCAl, the customer receives its products on time and ensures market share for the manufacturer. Considering higher volumes, customised products and unpredictable demand patterns, the need for SCAG, SCAd and SCAl shows characteristics of strong, reciprocal interdependence where supply chain partners depend mutually on “get it right” in production and delivery schedules. This is why the manufacturer implemented cross-functional meetings which focus on selected products in large markets representing reciprocal interdependencies to develop their inter-organisational business processes. Thereby, the manufacturer strives to better plan production and logistics activities with better service to the market.

3.4.3 Optimal Levels of Supply Chain Agility, Adaptability and Alignment

The analysis of the interviews along the complete supply chain (supplier, manufacturer, customer) shows that the interviewees’ understanding of SCAG is consistent with Lee’s definition (2004), namely the competence to adapt the SC quickly to market requirements with a flexible (IT) system, flexible processes and a flexible organisation. SCAG can only be achieved if flexibility is present. SCAG supports the supply chain’s ability to react efficiently to changes in the market, e.g. market growth or shrinkage. This flexibility results in higher sales and revenue as well as less obsolete stock. Higher SCAG can increase customer satisfaction due to short lead and delivery times. The interviews showed that SCAG can be found in the internal as well as external supply chain. This is in contrast to the literature (Prahalad and Hamel, 1990; Teece et al., 1997; Zhang et al., 2002, 2003), where SCAG refers mainly to external changes, while the term ‘flexibility’ is used for internal activities.

All managers agree that current and future business is significantly influenced by increased SCAG. The benefit of higher SCAG results in a reduction in through-put times and higher customer satisfaction due to reliable delivery times and product availability. Interviewees added that information from forecasts, local-for-local sourcing, strong supplier integration as well as advanced IT support all increase supply chain agility. The interviewees from the manufacturer identified several internal company conditions necessary for creating agility. For one, on a human resources level, flexible shift models are necessary to cope with changes in demand, i.e. in times of high customer demand employees work overtime and in periods of overcapacity employees reduce their working hours. Today, such adjustments to the flexibility of working hours are long lasting due to demanding agreements between the employer and trade union representatives. Additionally, targets need to be defined in such a way that they are transparent and progress is visible. Qualification and training for employees strengthen their understanding of processes so that problems or disruptions can be solved faster. An example in the company under study is that the SAP system is heavily customised so that special know-how is needed to start transactions like availability reports or picking lists.

According to the interviewees, another condition required for an agile supply chain is the implementation of a comprehensive planning system. The planning system is not only relevant for internal capacity or resource plans; it is even more important for external interfaces towards the upstream and downstream supply chain partners to be implemented. Managers emphasise the need to create a demand plan based on volume or quantities, respectively. The head of logistics stated: “Contrary to our business plan, which is created in monetary values, we need an additional plan which is based on volume and quantities. This is the only chance to prepare a solid capacity plan. Only if we know quantities, we can manage our warehouses properly.” This means that demand planning based on quantities/pieces in the upstream and downstream supply chain enables managers to optimise their decisions concerning personnel and inventory. As soon as demand increases and is reflected in the planning, purchasing can involve its suppliers on time so that the order fulfilment can be satisfied without increasing costs for inventories. One senior logistics manager confirmed: “We need to expand and improve our demand planning based on quantities. The input from sales is very important for our suppliers in terms of delivery times, but also for internal capacity

planning and through-put times.” Finally, these decisions make it possible to achieve targets and improve KPIs. This statement further suggests that an agile supply chain relies on the cooperation of different internal functions, but also external supply chain partners, so that the process and not the function is in focus.

With an agile supply chain, customers expect to make call-offs with flexible quantities to keep their stocks and the costs involved as low as possible. The expectation for the call-off is to decide the point of time when they need the products, but also flexibility regarding the quantity as well as on the final product variant.

With an increase of SCAG to achieve higher customer satisfaction, the managers from the manufacturer see a risk of increased logistic costs as – for example – higher inventories may be provided at different supply chain locations to achieve short and reliable delivery times. As inventory in the investment goods industry causes high costs, the manufacturer will seek to have his suppliers provide stocks according to the manufacturer’s demand. This may cause investments in additional warehouses for the supplier. An increase in SCAG means that processes change quickly; this requires investment in employee trainings and qualifications, such as IT courses or additional training on the job. On the other hand, all managers uniquely stated that an agile supply chain, from the supplier to the customer, is absolutely necessary to stay competitive in the market. This is especially the case if the company is confronted by a high level of SCC. Swafford et al. (2008) argue that organisations with supply chain agility can better react to unexpected events. Moreover, agile supply chains are more market-oriented because they are better able to synchronise supply with demand.

In the next step the interviewees were asked about supply chain adaptability along the complete supply chain, i.e. differentiated by supplier, manufacturer and customer. While SCAG implies short-term flexibility, SCAd focuses on the capability to adapt to changes in the environment in principle, not necessarily under any time restrictions. The regional head of logistics stated: “We need to create our processes more efficiently. An increase in local suppliers improves to shorten our delivery times towards the customer. Additionally, we can grow more if we expand our logistics processes towards our customers and suppliers”. Regarding activities to increase SCAd, the managers revealed that they are quite similar to those required to increase SCAG, whereas a difference can only be seen in terms of time. While SCAG measures can be realised in the short term,

SCAd activities take longer; for example, supplier integration measures or adapted distribution measures require more time to synchronise processes and set up common conditions. In terms of the downstream supply chain, intense customer contact is needed to understand the requirements of changes in demand or product development, and analyse whether the manufacturer has the competence to fulfil these requirements. Even small customers with high margins need to be involved in the SC design to satisfy their needs. With this information the manufacturer can adapt the upstream supply chain accordingly so that a win-win situation can be achieved for all supply chain partners. Defining supply chain alignment as the willingness to synchronise supply chain processes with the target of cost reductions or increased order fulfilment to satisfy customer requirements, this study identified two different types of SCAl. These are called vertical supply chain alignment and horizontal supply chain alignment (Figure 3.2).

Figure 3.2: Vertical and horizontal supply chain alignment

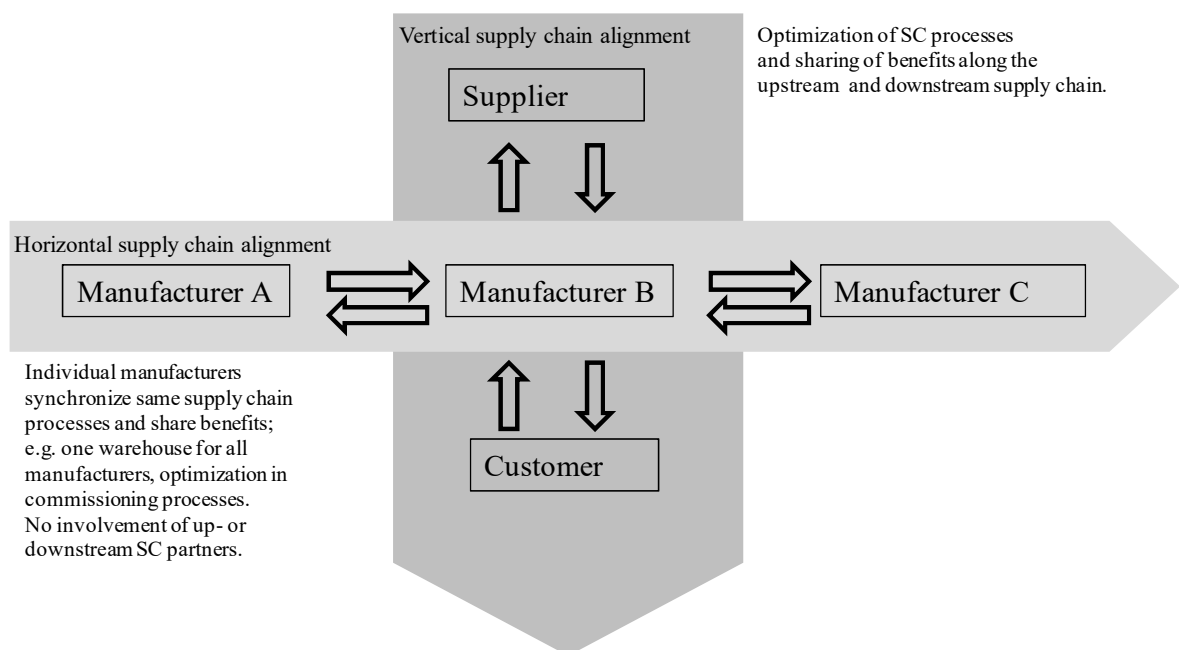

In the case of vertical supply chain alignment, defined supply chain processes from upstream to downstream supply chain partners are synchronised so that benefits are ultimately shared among all partners. For example, with an integrated demand planning process started by the customer, the manufacturer is able to provide capacity and resources appropriately. At the same time, the supplier also receives information about demand development so that parts or material can be ordered in the optimal quantity.

The transparency created by this information enables the complete supply chain to avoid inventory costs or obsolete stock. The supply chain partners share common information so that material flows can be optimised individually.

Alliances should be developed with key supply chain members to meet customer requirements and reduce total delivered cost to the customer. The objective is to develop a seamless process from the supplier to the organisation and then on to its various customer segments (Lambert et al., 2000). In the case of horizontal supply chain alignment, the independent business units of a group synchronise identical supply chain processes to share benefits. Usually, these manufacturers share the same processes not only in terms of information flow, but also in terms of material flow. As the manufacturers share the same buildings and premises, synchronisation can be achieved for processes like picking or dispatch.

Both vertical and horizontal supply chain alignment offer a win-win relationship in which the supply chain partners involved benefit, as well. This is a change away from the traditional bid-and-buy system and the integration of key suppliers early in the design cycle, which can lead to a dramatic reduction in product development cycle times (Lambert et al., 2000). Next a resource dependence perspective (Pfeffer, 1981; Priem et al., 2012) was used and a resource-based view (Hunt et al., 2012) of the firm to develop a theoretical lens through which to view SCM. This is used to make a more general case for why the explicit incorporation of SCM activities into an organisation's agility practices can further enhance the organisation's long-term viability.

Thus far, this case study has delivered examples and findings of how to improve and advance SCAG, SCAD and SCAL. However, it also has to be clarified how an optimal level can be achieved. As SCAG, SCAD and SCAL always go along with changes in supply chain design it can be argued that an optimally designed supply chain should, through one or a variety of metrics, reflect the "best" configuration and operation of all of these elements (Wassick, 2009; Garcia et al., 2015). Nonetheless, optimising a supply chain can be technically challenging task, especially for large ones. For the implementation of an optimal level for SCAG, SCAD and SCAL, an iterative approach is recommended to be adopted where the dimensions of responsiveness, speed and efficiency are identified and evaluated. With the iterative approach, the optimal level of an activity is achieved when hardly any new findings can be observed after the

implementation of any activity out of the dimension of SCAG, SCAd or SCAl. Literature (Mihalís et al., 2016) offer a multi-agent model where the roles for each of the agents within the framework are defined and the interactions among these agents are modelled. The model can potentially provide enhanced levels in each of the dimension of supply chain agility. It shows how the multi-agent system can assist to overcome the trade-off between supply chain agility and complexity of global supply chains. Optimisation and optimal control of multi-echelon supply chain operations is difficult due to the interdependencies across stages and supply chain partners (Gattorna, 2016). The resulting models can usually not be solved numerically due to the high dimension of the state space for instances of realistic size. Many customers require special maintenance services provided in different locations and for different products where different departments are involved. In order to achieve an optimal level of reciprocal interdependence for SCAG, SCAd and SCAl, a DES model is recommended to manufacturers. At the beginning of each iteration, an optimisation model for each supply chain activity defines the quality of the measure so that finally managers can decide on the outcome if the supply chain will be adapted or not. This iterative procedure continues until the performance gap becomes minimal.

3.5 Summary of Case Study Findings

Lee (2004) provides the basic definition of the triple-A qualities of SCM and offers insight into the role of each of the three triple-A elements. The three elements comprise supply chain agility, supply chain adaptability and supply chain alignment. Definitions of the triple-A are explored by a case study to gain more insight from practitioners and reflect the findings with literature. The case study further explores how the triple-A affect KPIs in the complete supply chain, including upstream and downstream supply chain partners. Figure 3.2 shows the framework of the triple-A elements explored in this research. It depicts each element in terms of the time needed for realisation and describes exemplary measures and their effect on KPIs. This case study provides further an overview of operational, tactical and strategic KPIs in Table 3.2 which are used by the manufacturer of this case study to measure progress of activities for SCAG, SCAd and SCAl. The results of the interviews show that the time aspect which is associated

with each of the triple-A, is reflected in the relevant type of KPIs. Managers are thus able to define selective activities on the three supply chain qualities. Based on the findings of the interviews and referring to the explored KPIs shown in Table 3.2., the following hypothesis can be offered:

Hypothesis 1a: A higher level of short-term activities on SCaG leads to better results of operational KPIs.

Hypothesis 1b: A higher level of mid-term activities on SCAd leads to better results of tactical KPIs.

Hypothesis 1c: A higher level of long-term activities on SCAl leads to better results of strategic KPIs.

Further, this case study offers a framework for a “Triple A Supply Chain” in Figure 3.1. Each quality can be fulfilled according to a different time aspect. Although the interviews show that supply chain alignment is the utmost target of the manufacturer, activities on supply chain agility and supply chain adaptability are necessary in advance to achieve this target. This gives an indication of a reciprocal interdependence between the three “A”s according to Thompson’s (1967) theory. The manufacturer in this case study motivated some high-volume suppliers to install supplier storages close to the premises of the manufacturer. With this agreement and thus alignment of the supply chain, the manufacturer received a guarantee to have all necessary parts available without having them in his own stock. On the other side, the supplier had a commitment for being registered as long-term supplier to the manufacturer. Based on the outcomes of the interviews the incentive for the manufacturer of an aligned supply chain is that costs, benefits, but also risks among all supply chain partners can be shared so that it can be argued that the installed activity will be defined as standard. Therefore, the following hypothesis is offered:

Hypothesis 2: The higher the level of reciprocal interdependence, the higher the level of supply chain alignment.

The results of this research indicate that supply chain agility, adaptability as well as alignment provides positive effect on a company's operational, tactical and strategic performance. The result shows also that supply chain alignment provides the greatest financial benefits and lead time improvements for all partners of the supply chain, including both suppliers and customers. This approach confirms the research of Zhang et al. (2003) or Swafford et al. (2006) by stipulating that internal and external integration is also necessary to create an agile and aligned supply chain. In order to achieve this target condition, a strong involvement of all supply chain partners is required, and this can be achieved only on a long-term basis. To achieve an aligned supply chain, therefore, companies should implement SCAG measures of a more short-term nature as well as SCAd measures on a mid-term horizon. It can be concluded that a supply chain alignment can only be achieved by including SCAG and SCAd measures, as well. By conducting the case study, the typical characteristics in terms of time and scope of the three attributes coincide with the findings in literature (Prater et al., 2001, Braunscheidel et al., 2009, Lee, 2004, Christopher et al., 2004). In summary, this research extends Lee's (2004) investigation by differentiating the analyses according to the main supply chain actors. The main difference arises from the time aspect required to realise a measure. Considering the different time aspects of the three supply chain qualities and linking them to the manufacturers KPI system, the following hypotheses are offered:

Hypothesis 3a: The degree of short-term improvements of operational KPIs depends on the improvement level of supply chain agility.

Hypothesis 3b: The degree of mid-term improvements of tactical KPIs depends on the improvement level of supply chain adaptability.

Hypothesis 3c: The degree of long-term improvements of strategic KPIs depends on the improvement level of supply chain alignment.

New in this research is the extension of activities to achieve SCAG, SCAd and SCAl and the connection to KPIs. It is to emphasise that in a strongly aligned supply chain also external supply chain partners benefit from lower logistics cost or shorter lead

times. This presents a clear incentive to all supply chain actors. With this research it is shown how companies can use existing operational, tactical and strategic KPIs as basis for further activities on supply chain agility, adaptability and alignment. Additionally, examples of measures are presented which offer an impact on a higher level of SCAg, SCAd and SCAl. A special contribution of this research is the discussion about interdependence of the triple-A. This discussion is not yet covered in topical literature of SCM. The findings discussed in Section 4 enrich the academic discussion in the field of SCM und provide support for managerial decisions. With these findings, managers are now able to improve their activities on a more agile, adaptable and aligned supply chain.

3.6 Conclusion

This study extends Lee's (2004) research on triple-A (agility, adaptability and alignment) in SCM. The literature review in this research gives an overview of the academic discussion of each of the three elements and led to the development of research questions whose exploration generated a novel contribution to academic literature.

In order to conduct an in-depth analysis and provide a better understanding on the research topic, a case study was carried out to gather data both from the manufacturer and from suppliers and customers. The inclusion of data from external supply chain partners is new in this field of research. This case study suggests explicit measures that can be used to develop an agile, adaptable and aligned supply chain. Another new contribution is the differentiation between horizontal and vertical supply chain alignment. This exploration supports managers in their decisions concerning how to implement and improve SCAg, SCAd and SCAl. This case study shows that measures to promote these qualities are of high importance for managers in achieving an aligned supply chain which is of highest priority due to cost and efficiency reasons. While supply chain alignment usually involves additional external supply chain partners and is more time-consuming in terms of developing a common understanding of processes and structures, measures to increase supply chain agility are seen as a short-term activity. The target of an aligned supply chain – either horizontally or vertically – is for all SC

partners to benefit from any improvements such as sharing costs and benefit from each other's processes so that strategic KPIs can be improved. The results indicate that supply chain managers need to strategically review their processes to identify possibilities for increased supply chain agility. At the same time, managers need to enforce their supply chain collaborations so that the benefits of an aligned supply chain can be realised.

Another new and valuable contribution of this paper to literature and practitioners is the allocation of KPIs to the dimension of SCAG, SCAd and SCAl. At the same time also interdependencies could be explored in detail. They brought interesting evidence and these findings offer now the opportunity to define and implement specific supply chain activities. A novelty is the exploration of reciprocal interdependence and its impact on a supply chain. This paper seeks to look beyond the commonly researched interdependencies of dyadic relationships and explore interdependencies of SCAG, SCAd and SCAl. Thompson (1967) offers three types of interdependence: pooled, serial and reciprocal interdependence. The study has explored which activities are currently implemented from a manufacturer in the machine construction industry to achieve SCAG, SCAd and SCAl, considering also whether such activities are characterised by pooled, serial or reciprocal interdependence. This study stresses the importance and role of reciprocal, serial and pooled interdependence (Thompson, 1967; Dubois et al., 2004) for SCAG, SCAd and SCAl. More specifically, reciprocal interdependence appears to be the strongest type in terms of intensity and entails activities in SCAG, SCAd and SCAl.

In summary, the analysis explored the triple-A in greater detail and determined that it will be of major impact and challenge for a company's competitiveness in the future. By creating a framework for the triple-A, the case study provides support for managerial decisions by defining measures for increasing these factors and identifying their impacts on KPIs. However, as this is an evolving research area, further investigations are needed; for example, on target definitions with SCAl among external SC partners or how to quantify the impact on KPI. Accordingly, these aspects should be explored in future research.

Despite having conducted a detailed literature review, the present research has its limitations. First, the research is based on a single case study which may provide generalizability for the machine construction industry in Germany. However, further

research is needed for other industries as well as regions. Bearing this in mind, other studies may report different findings. To strengthen the generalizability, it is recommended that future researchers consider samples from other industries and cultures.

4 Reduction of SCC by Redesigning the Supply Chain: A Discrete-Event Simulation in the Machine Construction Industry³

Financial Times (2016) argues that many supply chain problems are generated by operational actions in industry. A manager states in an article that much of the supply chain is floating on the ocean, so that strikes in the port can delay shipment of goods and parts and endangers the manufacturing process. He says additionally, that customers are increasingly part of the problem. “Consumers are also triggering more volatility because they have access to so much information for decision making that they have become more fickle and there is a lot less brand loyalty.” Further on, today’s tougher regulatory environment can raise issues further down the supply chain, says French Caldwell, a senior executive with MetricStream, a supply chain compliance software company. He says: “Organisations are increasingly being held responsible for the actions of their suppliers. You can no longer claim to be unaware if your supplier breaches regulations on product specification or workplace safety.”

Another manager states in an interview with the Financial Times (2016): “We have made advances in statistical analysis, taking into account seasonal impact at a more local level”. In this case combining predictive analytics with radio-frequency identification (RFID) tagging and internet of things technology can help minimise transportation hazards, e.g. by spotting potential component failure in advance. This enables pre-emptive action and minimises downtime. Carmaker Volvo is applying SAS software to its fleets of trucks and buses to replace parts before vehicles breakdown. It analyses more than 100 parameters to predict the wear on a component, identify abnormalities and speed up the diagnostics of incidents affecting vehicles. RFID tags and sensors on goods in transit can also raise alerts when product quality is threatened by – for example – warning that the refrigeration unit on a truck has failed, so potentially damaging foodstuffs. Analytics can also be applied to meteorological forecast data to predict possible shipment delays caused by storms at sea. These

³ Malina, S., Spinler, S., 2018. Reduction of SCC by Redesigning the Supply Chain: A Discrete-Event Simulation in the Machine Construction Industry. Unpublished manuscript.

statements in the Financial Times offers insights into the challenges of existing supply chains and arising SCC.

The objective of managing and aligning the supply chain is to synchronise customer requirements with the flow of material from suppliers to equalise conflicting goals of high customer service, low inventory cost and low unit cost. The design and operation of an effective supply chain is of fundamental importance to every company. It is important to understand that customer satisfaction covers all of the points of contact between the customer and the supplier in terms of order processing, delivery performance, sales services, technical support, financial packages, etc. The following paper investigates such trade-offs under a DES model. For the benefit of such trade-offs to be fully achieved it is necessary to think of a single integrated supply chain rather than functional areas. To resolve these problems effectively and develop the supply chain into a weapon for gaining competitive advantage, it requires the development of an integrated supply chain driven by the needs of the business (Stevens, 1989).

4.1 Introduction

SCC and supply chain agility are two popular keywords in SCM. As new keywords are developed and promoted the affinity is to discuss them in a progression and in separation. Therefore, there was first the request to deal with the topic of SCC and manufacturers should align to become agile (Booth, 1996; Ward, 1994; Lee, 2004). This paper provides a simulation tool to study how SCC may be managed through supply chain agility and its effect on supply chain performance, i.e. development of inventory levels, logistic costs and order fulfilment. It will show how the need for agility and complexity depends upon the total supply chain strategy and that supply chain agility is best suited to satisfy a volatile demand (in terms of volume and variety) under cost optimisation for inventories and order fulfilment aspects.

The paper starts with the background of supply chain simulation, especially on system dynamics (SD) and discrete-event simulation (DES). It contributes to the ongoing discussions about SCC and supply chain agility by providing insights into an existing supply chain of an OEM and its optimisation approach by redesigning the supply chain.

For this approach, a DES model is created. With the computer-supported approach of SD, complex problems can be solved and analysed. Initially called “Industrial Dynamics” (Forrester, 1961), the field developed from the work of Jay W. Forrester at the Massachusetts Institute of Technology. SD has its origins in control engineering and management; the approach uses a perspective based on information feedback and delays to understand the dynamic behaviour of complex physical, biological, and social systems (Lane, 1997). Lane (1997) summarises Forrester’s approach to modelling and understanding management problems as “... social systems should be modelled as flow rates and accumulations linked by information feedback loops involving delays and non-linear relationships. The purpose is to learn about their modes of behaviour and design policies which improve performance”. In order to respond to customer demands like shorter lead times, increased delivery frequency as well as higher quality of process and product, simulation models are built to analyse distribution systems. They are able to evaluate and quantify logistic and financial performances in different areas e.g. in catering supply chains, health systems or financial market scenarios (Jansen et al., 2001; Jun et al., 1999; Jacobs et al., 2004).

Section 4.2 provides an overview of supply chain simulation with focus on SD and DES in SCM. As SCC plays also an important role for the development of the model, a short review will be included on this topic. Section 4.3 provides a DES model based on the findings of previous case studies on SCC and supply chain agility. A simulation will follow to quantify effects from the model. Section 4.4 contains a scenario analysis with simulation of growing and shrinking market conditions, while Sections 4.5 and 4.6 end with findings and conclusion of the paper.

4.2 Literature Review

4.2.1 Background Discrete-Event Simulation

Strategic SCM deals with a wide range of decision-making problems that concern the long-term development and operations of a firm like e.g. number, location and capacity of warehouses and manufacturing plants, material flow through the supply chain network, inventory management policies, supply contracts, distribution strategies,

supply chain integration, outsourcing and procurement strategies, product design, decision support systems and information technology (Georgiadis et al., 2005; Pierrel et al., 2007). Simulation is used to manage stochastic properties which occur in supply chains. Additionally, with the support of simulation, optimum values can be found for the complete supply chain (Lee et al., 2002; Eskandarpour et al., 2015; Ge et al., 2015).

In this paper, the problem of a firm's performance in terms of inventory management is investigated and simulated. Due to the fast-changing volatile demand and factors from SCC – as discussed in further detail in Section 4.2.3 – managers need to make their decisions under time compression. The methodological approach developed in this paper could potentially be used for capturing most of the above strategic SCM problems. Since each of the problems has its unique characteristics, guidelines for the methodology are presented and further analysed in depth by a specific strategic management problem, namely long-term inventory planning. The approach is to use the well-proven and accepted methodological tool for decision-making with DES.

Apart from SD, discrete-event simulation DES is a widely-applied modelling tool for supporting and confirming decision support management. In the area of SCM simulation-based DES provide solutions on a strategic, tactical and operational level. Some specific examples of the issues that DESs address include supply chain design and reconfiguration, inventory planning and management, production scheduling and supplier selection (Tako et al., 2012; Persson et al., 2009).

In the late 1950s DES and SD were developed independently from each other, with very little communication between the two fields. The existing work largely comprises opinion-based statements which are often influenced by the authors' field of expertise (Tako et al., 2010). It has been argued that DES and SD are quite different modelling approaches, especially in terms of the type of problems modelled (Brailsford et al., 2001). The general attitude is that DES is considered as more applicable for modelling problems at an operational/tactical level, whereas SD is more suited to modelling problems at a strategic level. However, others claim that the separation between the two modelling approaches might not be that unique. Different aspects of the same problem may be highlighted by each modelling approach (Morecroft et al., 2005). On the contrary if the problem is similarly represented in both methodologies, similar outcomes can be expected from the users' perspective (Tako et al., 2009).

DES as well as SD are both developed to observe and understand how systems behave over a certain period and compare their results under different premises (Sweetser, 1999). However, some technical aspects have to be considered and differentiated in the two modelling methodologies due to their principles. While e.g. DES models systems as a network of queues and activities where state changes occur at discrete points of time, SD models represent a system as a set of stocks and flows where the state changes occur continuously over time (Brailsford et al., 2001).

In DES, entities – e.g. objects or people – are represented individually. Each entity can get specific attributes which determine the behaviour throughout the simulation. Opposite, in SD individual entities are not specifically modelled, but instead they are reflected as a continuous quantity in a stock. DES models are usually stochastic in nature, where randomness is created through the use of statistical distributions. In general, SD models contain feedback loops, they are deterministic and variables represent average values. In DES models state changes appear at irregular discrete time steps, while in SD state changes are continuous, approximated by small discrete steps of equal length. More information about these modelling approaches can be found in relevant textbooks (Law, 2007; Pidd, 2004; Robinson, 2004; Sterman, 2000).

4.2.2 Application of Discrete-Event Simulation

The main reason to apply DES for system analysis in SCM is the option to consider dynamics as well as the simplicity of modelling. DES is advantageous for studies where time-dependant relations are analysed. Simulation can reflect uncertainty and complexity which supports supply chain analysis (Jain et al., 2001, Persson et al., 2009). Manivannan (1998) provides examples of supply chain simulation e.g. in the area of warehousing, distribution systems or trucking operations.

Jain et al. (2001) argue that the level of details is one of the major problems in supply chain simulation. Usually, the level of detail should reflect the objective of the analysis. Therefore, the decision concerning the level of detail is an important topic in supply chain models. Moreover, the model has to be valid so that results are useful. Due to the lack of data or system experts, validation of a supply chain model can be a difficult task.

Manivannan (1998) emphasises that complexity in supply chains is one of the main obstacles in supply chain simulation software followed by unfamiliarity to simulation in the logistics industry. The wide use of optimisation methods in SCM as well as the closed-form solution of problems are other challenges for simulation.

Banks et al. (2002) explore the difference of supply chain simulation and other simulation applications. A major differentiating criterion from e.g. simulation of manufacturing systems is that supply chain models contain aside information flows also flow of materials, i.e. that different levels of detail have to be managed in the simulation. Different supply chain actors store data differently so that it is more difficult to collect relevant data. Consequently, it is difficult to model the complete supply chain on the same level of detail. The problems with diverse levels of detail as well as the size of supply chain models often require a large number of alternative scenarios with efficient experimental planning. As subjective methods like walkthroughs are rather impossible to undertake on the supply chain level, validation is another topic where simulation in SCM is difficult. Sub-model validation is a possibility for the problem of huge systems as long as system experts with a detailed knowledge about the whole supply chain are not available in the whole supply chain (Persson et al., 2009).

4.2.3 The Role of Supply Chain Complexity (SCC)

With changing customer requirements, competition and regulations, SCC increases, as companies form strategic partnerships with suppliers, outsource services or explore new markets. The rapid increase of SCC seems to be supported and enhanced by customisation, innovation, globalisation, alliances and flexibility (BCG, 2018). Wilding (1998) was one of the first using the term SCC. He defines supply chain complexity as *deterministic chaos, parallel interactions and amplifications*. Sivadasan et al. (2002b; 2004) suggest that complexity can be managed by transferring it to other parties, charging for creating complexity, increasing resources for the elimination and finally by the avoidance of complexity. Sivadasan et al. (2002b; 2004) argue that the management and prevention of complexity depend on a company's resources like time, stock, IT systems or decision-making processes. Perona et Miragliotta (2004) proceed similarly with the management of SCC. They develop a normative complexity model where the

actual complexity is the result of basic complexity reduced by complexity reduction levers. In order to minimise disruptions in a system caused by complexity and smoothen supply chain processes, flexible manufacturing processes (Gordan and Graves, 1995; Sethi and Sethi, 1990) or flexible supply via multiple suppliers (St. George, 1998) are discussed. Towill (1996b) states that rapid, effective and efficient response to changes in the market is one of the main challenges in modern supply chains. As supply chains move to more complex systems (Warnecke, 1993; Tharumarajah et al., 1996; Choi et al., 2001; Surana et al., 2005; Mason, 2007), researchers aim for more robustness, agility, autonomy and emergence in logistics systems through different types of manufacturing (Okino, 1993; Ueda, 1993; Winkler et al., 1994; Iwata and Onosto, 1994; Gunasekaran and Ngai, 2004; Scholz-Reiter et al., 2004). What all of these concepts have in common, is the objective of adaptive supply chain processes that ideally autonomously react to the complex and changing demands of their environment to compete profitably in highly competitive but changing markets. With these conditions, this paper provides a DES of complexity drivers throughout a supply chain, where all supply chain partners can act profitably as a result of an aligned supply chain.

4.2.4 Research Motivation

Supply chains can be defined as an integrated network of facilities and transportation options for supplying, manufacturing, storing and distributing materials and products. They differ tremendously in size, complexity and scale from industry to industry (Garcia et al., 2015). Standard elements of supply chains usually involve suppliers, manufacturers and distributors. In the physical dimension, these elements are linked to processing facilities, factories, trucks, trains, sea-faring vessels, and warehouses. An optimal designed supply chain should, through one or a variety of metrics, reflect the “best” configuration and operation of all of these elements (Garcia et al., 2015). However, a supply chain comprises independent entities whose first interest is optimisation of their own business (Wassick, 2009; Ge et al., 2015; Eskandarpour et al., 2015). Optimising a supply chain can be a technically challenging task. A global supply chain is a large-scale, complex system that comprises a variety of supply, production, and distribution facilities (Ottino, 2011). There will also be an assortment of

transportation options with different lead times, which link these entities together and create an integrated network. Apart from this network, a supply chain underlies a variety of uncertainties, such as supply disruption, changing customer requirements, global price changes of commodity goods, etc. (Garcia et al., 2015). Thus, there is great economic potential and practical need to optimally design and coordinate all activities of all supply chain partners to achieve smooth operation for large and complex supply chains (Garcia et al., 2015). Consequently, optimisation models and methods for supply chain design and operations have been of great interest to industry and academia over the past decades (Grossmann, 2012; Chopra et al., 2012; Barbosa-Povoa, 2014). Instead of reviewing now excellent review papers (Grossmann, 2012; Chopra et al., 2012; Barbosa-Povoa, 2014) on process supply chain modelling and optimisation, the scope of this paper is restricted to supply chain optimisation in complex supply chains. In this context, the following questions arise:

(1) How can an existing supply chain be redesigned to fulfil lead times?

Order fulfilment in terms of lead times is an important competitive aspect for manufacturers (Huebner et al., 2016; Reaidy et al., 2015). Lead time in this paper is to be understood as through-put time from order entry at OEM until dispatch of goods to final customer. This question will be explored by adapting an existing supply chain design of a manufacturer. By executing a comprehensive DES, effects on various KPIs can be investigated. The simulation includes a defined product program and looks in detail into the behaviour of cost and performance development.

(2) How robust is a redesigned supply chain if market conditions change?

Robustness of supply chains especially in consideration of demand uncertainty is an important topic in literature (Brandon-Jones et al., 2014; Durach et al., 2015; Tang et al., 2016). This simulation offers insights into how costs as well as delivery performance behave when decrease demand shock occurs after redesigning the supply chain of a manufacturer.

This research offers a simulation model based on the data of a manufacturer out of the drive and control industry. The study not only provides a contribution to literature by offering more insights into the machine construction industry, but it also supports

managers in taking their decisions concerning optimising their inventories as well as logistics costs.

4.3 Supply Chain Redesign

4.3.1 Supply Chain Design Approach from the Perspective of an OEM

A supply chain described as “extended enterprise” includes all partners like vendors, manufacturers, producers, distributors and retailers, extending over multiple echelons (Lee et al., 1999). Usually, each actor manages its own inventory independently, which is replenished from the upstream supply chain, applying a control policy to decide on the frequency and volume of the orders. Multi-echelon supply chains that fit real-world cases can be created by linking the appropriate number of single-echelon inventory models.

In this paper the manufacturer acts as global OEM for drive and control technology. The company is headquartered in Germany with 50 production locations in 20 countries and a sales organisation in 80 countries. For confidentiality reasons, the name of the company has been disguised. The majority of sales is generated in Europe, followed by Asia and America. This research concentrates on the supply chain from suppliers of steel as raw material, the manufacturing process through the OEM, the distribution and customising process to the sales organisation in the UK as well as the provision of the goods to the customers located in the UK. The OEM considers the existing supply chain as complex and thus as inefficient as many internal and external interfaces slow down the lead time and cause costs for high levels of inventory which have to be held available in the UK. The target of the simulation model is to support the redesign of the existing supply chain in that way that interfaces and processes can either be eliminated or modified so that this leads to cost reductions in inventory as well as to a reduction in lead times.

Using the DES approach this generic multi-echelon supply chain can be extended by adding strategic SCM issues. Decisions concerning inventory management which have to be taken from a complex supply chain system is the central focus of this paper. Generally, inventory determination is quite simple in a steady-state situation; however,

in an evolving complex and dynamic environment, as it is explored in this paper, it is important to consider a dynamic inventory policy. To develop a decision-making system for inventory planning, a firm needs to carefully balance the trade-off between customer service satisfaction (order fulfilment) and resource utilisation (optimal inventory management within the supply chain at lowest costs). Ideally, the supply chain is aligned in that way that supply chain processes can be managed with a certain degree of agility so that all supply chain partners benefit in terms of logistics cost and order fulfilment. As supply chain alignment plays an important role, the simulation in this paper will explore how costs and inventories change in case parameters change due to the redesign of the supply chain. The realisation of cost savings through the redesign of the supply chain provides an optimisation of costs and thus a competitive advantage for the OEM. The model in this paper is intended to consider the operational processes in the supply chain as well as the costs which are discussed in further detail in section 4.3.5.

4.3.2 Case Study: Status quo of Supply Chain

Section 4.3.1 presented an overview of the OEM of this case study. Further details regarding the existing supply chain are provided in this section. The relevant supply chain comprises one supplier, an OEM out of the hydraulic industry with three production plants in Germany and a sales organisation in the United Kingdom. Due to the given cost pressure for the OEM, the supply chain design of two major customers is reviewed. These customers are very powerful in the market and thus generate high sales volume for the OEM. Primarily, they purchase hydraulic parts like blocks and cylinder for their technical applications. For confidentiality reasons, names are disguised appropriately. The boundaries of the system are production start using raw materials on the upstream, and sales to the customer on the downstream. Essentially, the OEM produces all parts in different plants all over the world. In order to fulfil local customer requirements these parts are shipped to the warehouses of the sales organisations in the appropriate countries to do further customising and prepare local stock to enable short delivery times. This research concentrates on the supply chain of two customers who are headquartered in the United Kingdom and who receive their finished products

mainly from two plants in Germany. Further customising like painting or individual drillings and mounting is undertaken in the UK. Based on the order entry behaviour, it is assumed that all products underlie similar seasonality. In this case study, it can be observed that order entry increases usually in the second half of a year, when the OEM usually renegotiates contracts for the following year and customers start placing their orders. In the actual situation, the two specific customers provide delivery schedules which contains the information when they want to call-off which products in which quantities. Local sales engineers provide specific know-how to the customer for further product specification and product availability. The focus of the research is to analyse the development of inventory costs as well as of logistics costs of an up- and downstream supply chain in the machine construction industry. Both inventory and logistics costs have a negative impact on the financial result of the OEM and thus a reduction of these costs is to be achieved. On the other hand, delivery times have to be fulfilled so that a reasonable balance needs to be found. The existing supply chain is now reflected in a DES model. In another step the existing supply chain will be adapted so that the development of logistics costs as well as inventory can be further explored. The supply chain is capacity-constrained in terms of production capacity as well as transportation routes with long production lead times of 8 to 16 weeks and an increasingly dynamic market demand. The variability of the lead time depends on material availability of the supplier as well as on personnel capacity in the plants. Due to legal labour regulations in Germany, personnel flexibility in terms of additional shifts is very limited. Dynamic market demands are reflected in that way that despite the availability of delivery schedules, deviations in quantities do occur, e.g. order cancellations due to overcapacities with the customer or higher order volumes due to order backlogs. This puts pressure on time to market, product quality and supply chain flexibility. The problem in this case is the number of components in the manufacturing plants as well as the finished goods in the sales organisation and the logistics costs. While the OEM has its production in Germany, the customer is located in Great Britain and served through a local sales organisation. Currently, the manufacturer holds a high service level for the customer through a high degree of product availability in local warehouses. Additionally, customer satisfaction is achieved by direct communication between the customer and the sales organisation in the local language and the same time

zone. On the other hand, due to cost pressure the manufacturer is forced to adapt supply chain activities, e.g. consolidation of warehouses or direct deliveries instead of SDD.

Modelling the system requires inclusion of the following structural elements and their connections. In the next step a flow diagram shows the information and material flow first as per status quo (Fig. 4.1). It is a simplified illustration of the existing supply chain, but it shows which stages have to be passed. In this case, the manufacturer is classified as OEM which is headquartered in Germany. Here the products are provided as semi-finished or finished products before they will be dispatched to the sales organisation in the United Kingdom, where goods are stored in there in the warehouse again before they will be transported to the customer who is also located in the UK. Some semi-finished products receive some customised specifications like colouring or drillings for individual oil pressure adjustments before dispatch. Suppliers are spread worldwide, although the main production and assembly is conducted in Germany.

Fig. 4.1: Diagram of information and material flow; status quo of resale process

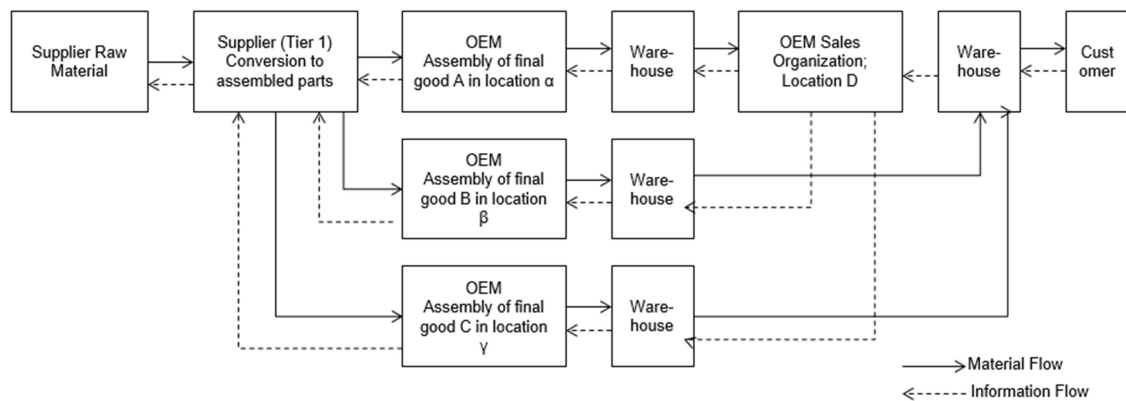

The resale process (Fig. 4.1) shows the status quo of the supply chain of the manufacturer. The customer will be served and delivered to via the sales organisation. In this model the country unit is responsible for sales and costs which arise locally. Contact person for the customer in terms of order processing or engineering remains in the sales organisation. In the status quo the existing IT infrastructure can be used for processing like the transmission of delivery schedules or tracking data regarding the production status. The target of the supply chain redesign is to reduce SCC by eliminating the process in the sales organisation including its warehouse. At the same time and under the given market pressure in terms of price and delivery time, the lead

time from order income until goods dispatch shall be reduced after redesigning the supply chain. For providing the supply chain redesign, real data from controlling reports for inventories as well as for logistics costs for the sales organisation in the United Kingdom were explored for the period of January 2013 until September 2014. This data is shown in Fig. 4.2. The illustration shows a constant increase of both logistics costs and inventories over a period of nearly two years, although the target is to decrease logistics costs and inventories. In order to achieve this target, the approach is to align the existing supply chain, i.e. that all supply chain parties involved are confronted by changes of processes.

Fig. 4.2: Development of inventories and logistics

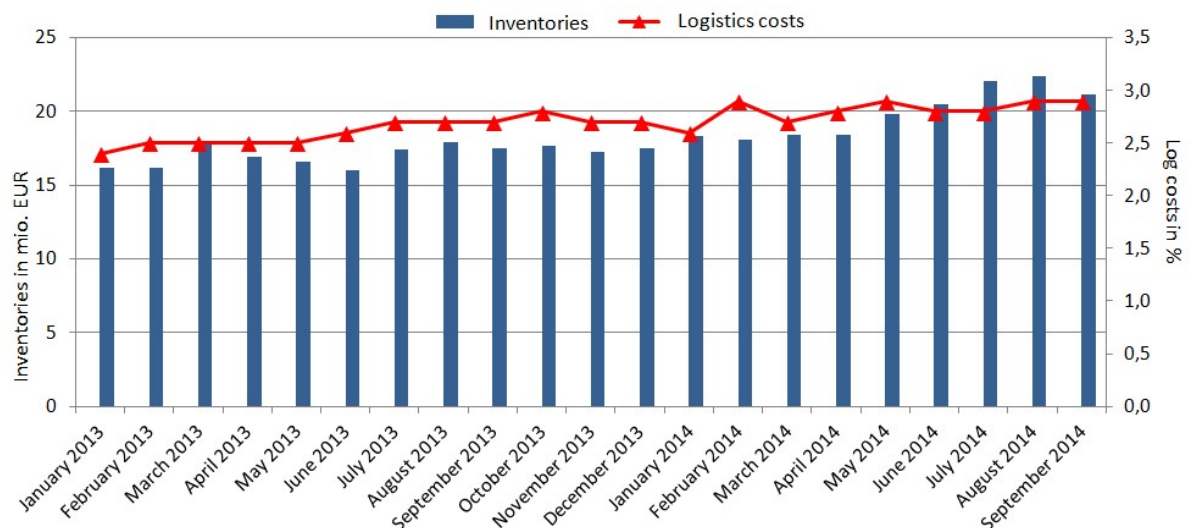

Fig. 4.2. shows the development of inventories and logistics costs in the sales organisation in the United Kingdom and thus represents a second warehouse stage for the OEM. Inventories include the value of semi-finished and finished goods. In order to fulfil delivery time requirements, inventory and thus logistics costs show a steady increase since April 2014. The manufacturer includes the following components in his logistics costs (all data is adjusted by currency effects):

- Inventory costs incl. capital costs
- Freight costs
- Packaging costs

- Personnel costs with relation to logistics
- Other costs (e.g. customs, scrapping, IT costs, other cost allocations)

Fig. 4.3 shows the distribution of logistics cost per type in percent. Main drivers of the logistics costs are inventories (ca. 40-50%) and personnel costs (ca. 30-35%) followed by freight costs (ca. 5-12%), packaging costs (5-7%) and others like capital charges and economic depreciation of 3 to 7 percent.

Fig. 4.3: Distribution of logistics costs per type in %

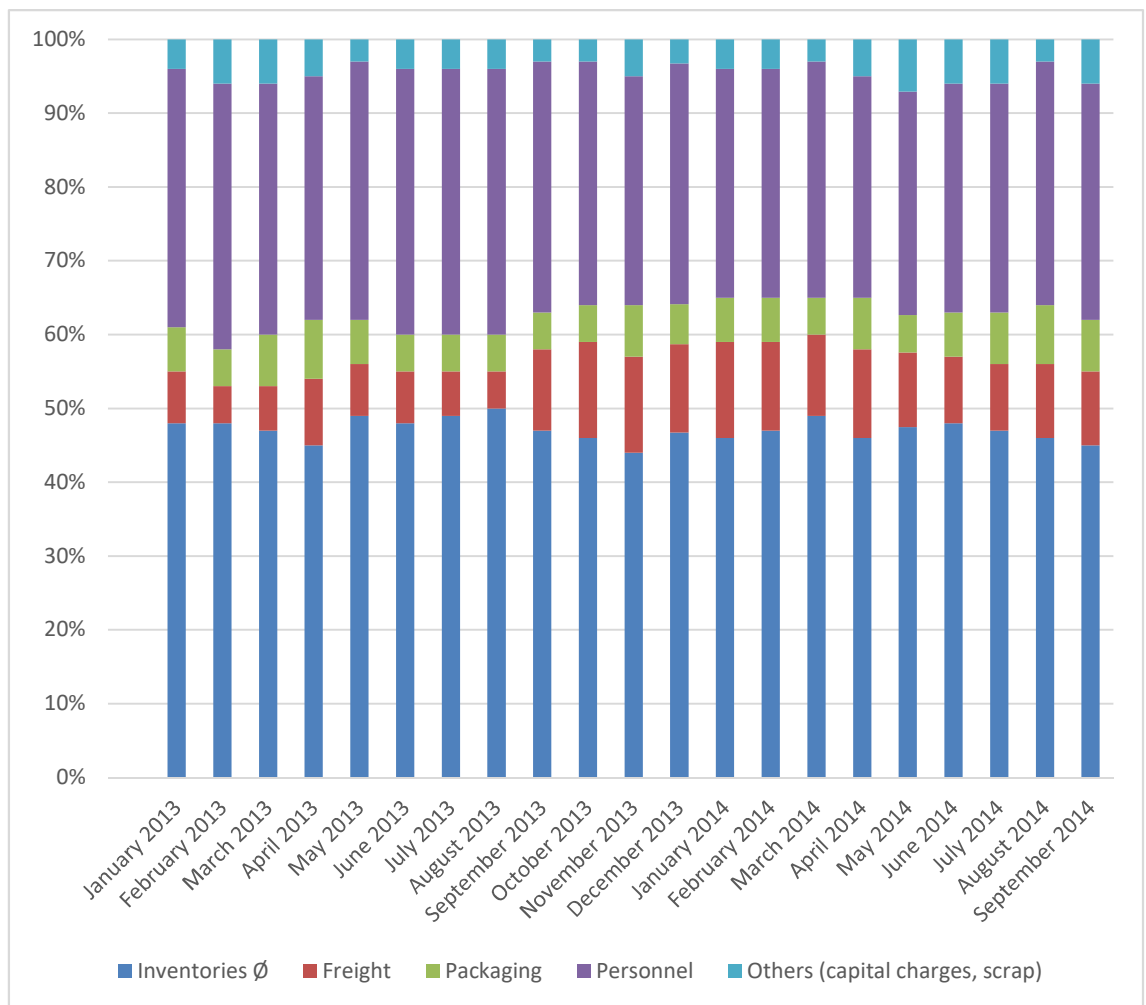

4.3.3 Future Simulation Concept

In a non-aligned supply chain, each actor decides on its inventory level based on relevant factors like number of suppliers, product variety, lead times, worldwide locations and demand. Customer requirements which lead to an increase of product variety request an increase of suppliers which have to be managed. For example, with the increasing activities of digitalisation in factories, parts may have to be mounted with additional electronic chips to enable the communication between products or machines. This product feature eases – for example – activities for remote maintenance. This means in case of technical problems, the machine can be maintained per remote so that the customer does not have to wait until a service engineer appears at his premise. This is quite new in industry and had not be considered so far. Further, differences or delays in lead times lead also to an increase of inventories, as products need to be buffered in stock before they can be worked on and shipped to the manufacturer or next actor of the supply chain. One of the most challenging variables for inventory planning are changes in demand. On the one hand, to achieve high order fulfilment and thus high customer satisfaction, the product availability shall be ensured. On the other hand, a reliable demand forecast supports this planning, although in many cases either the quality of the forecast is not sufficient or the customer is unwilling to prepare a forecast. Finally, due to an increasing level of global presence, inventory is not bundled at a central point and leads thus to an accumulation of inventories for the individual supply chain actor in total. The underlying assumption in a non-aligned supply chain is that each actor does not affect the behaviour of the others, i.e. each supply chain partner acts in a defined system where overlapping potentials cannot be realised due to missing information.

However, in an enhanced supply chain model all supply chain partners could potentially be included in the system boundaries to capture information and material flow effects for an optimised inventory management. In order to depict the desired optimisation the model is extended with the target to achieve an aligned supply chain. This means that through an increased transparency of information on demand forecasts throughout the supply chain system, decisions concerning material flow in the form of inventories can be taken accordingly. In case of higher demand, supplier can be informed about additional material accordingly. In addition, production may install additional shifts to satisfy order entries.

Providing the supply chain simulation, the new supply chain design is documented by a material and information flow diagram (Fig. 4.4). It shows the direct delivery process as schematic model which involves fewer entities compared to the existing structure so that it can be assumed that SCC can also be reduced. In the simulated direct delivery process, the OEM is directly sourcing from the various production plants of the Tier 1, whereas the sales organisation of the Tier 1 is no longer involved in serving the OEM.

Fig. 4.4: Flow diagram of information and material flow; simulated direct delivery process

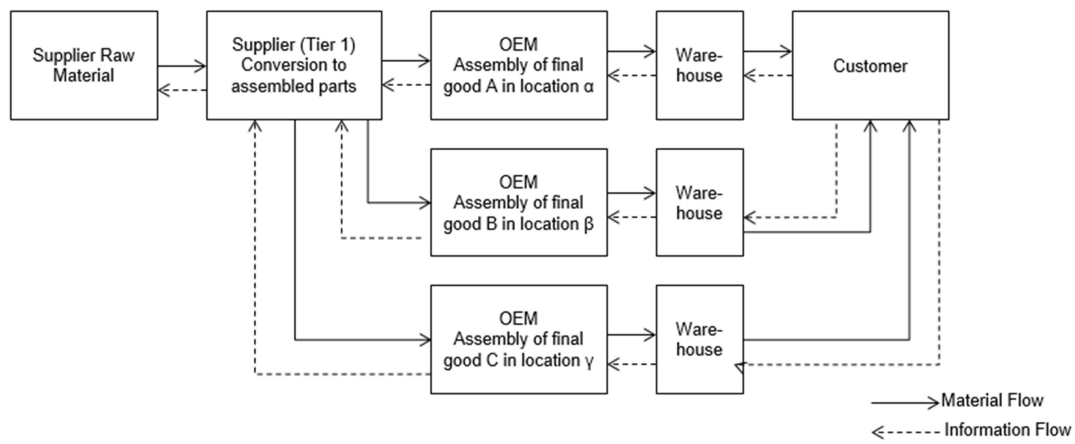

The simulated direct delivery process (Fig. 4.4) is based on the assumption that the customer places its orders directly at the manufacturing plant and also receives the goods directly from the plant without further involvement of the sales organisation. The consequence is that also sales will be generated at the plant and no longer at the sales organisation, but also the costs involved are under responsibility of the plant. The OEM has three different plants with appropriate warehouses in Germany, which will remain unchanged due to their historical background. Regarding IT infrastructure which is considered as important cost factor, the existing EDI connection from the customer needs to be connected directly to the relevant plants so the transmission of delivery schedules can be ensured appropriately.

The target is to install a forecast system in both the downstream and upstream direction so that each supply chain actor can manage inventories according to the supply and demand situation. This information is beneficial for all actors in terms of order fulfilment, as well as logistics costs. With the information on product availability, each actor is able to procure products accordingly, i.e. the procurement process can be

adapted to the availability of products. Additionally, through this behaviour logistics costs can be reduced as inventory costs and hence capital costs can be saved. The risk to build obsolete stock is also limited.

4.3.4 Simulation with ExtendSim®

ExtendSim® (originally named Extend) applies a message-based architecture for DES. Different information types are used to schedule events, propel items (entities) through a model, enforce the logic of the model, and enhance computation. The senders and receivers of messages are so-called blocks (operations), including the executive block (master controller for DES). In ExtendSim®, it is block execution that is scheduled (when a block executes, for example, this can trigger the sending of messages back and forth among blocks, with the effect of mobbing an item along its block-based path in a model) (Schriber et al., 2014).

The target of the simulation is to minimise the inventory level in the supply chain over a period. In detail, the target is to eliminate the sales organisation and its warehouse in the United Kingdom and provide the customers' goods in a warehouse in Germany so that either the customer picks up his goods from the plants in Germany or gets the products delivered to his premises in the UK. At the same time, the development of logistics costs is analysed. The assumption is to fulfil the planned lead time according to the various product groups. This fulfilment represents a reduction in lead time in comparison to the situation before the product groups were defined and the lead time was longer. The simulation shows how costs develop when the supply chain process is being changed to direct delivery and how this changes the development of inventory.

The question is: If SCC is reduced by eliminating some entities in the supply chain, does this automatically reduce inventory and/or logistics costs? For solving the considered problem, a simulation model is used that is realised in simulation package ExtendSim9 LT version, which is a very powerful and flexible simulation tool for analysing, designing, and operating complex systems in the market. It enables the researcher to test the hypotheses without having to carry them out. ExtendSim has often be classified of being able for modelling large complex systems (Krahl, 2007). By using

the different items from ExtendSim9 LT version, the supply chain has been drafted according to the existing and simulated process. The main screen of the generated simulation model for the supply chain is shown in Fig. 4.5. The simulation is executed on a Hewlett-Packard EliteBook (processor: Intel® Core™ i5-4300U CPU @ 1.90 GHz).

Fig. 4.5: Main screen of the simulation model

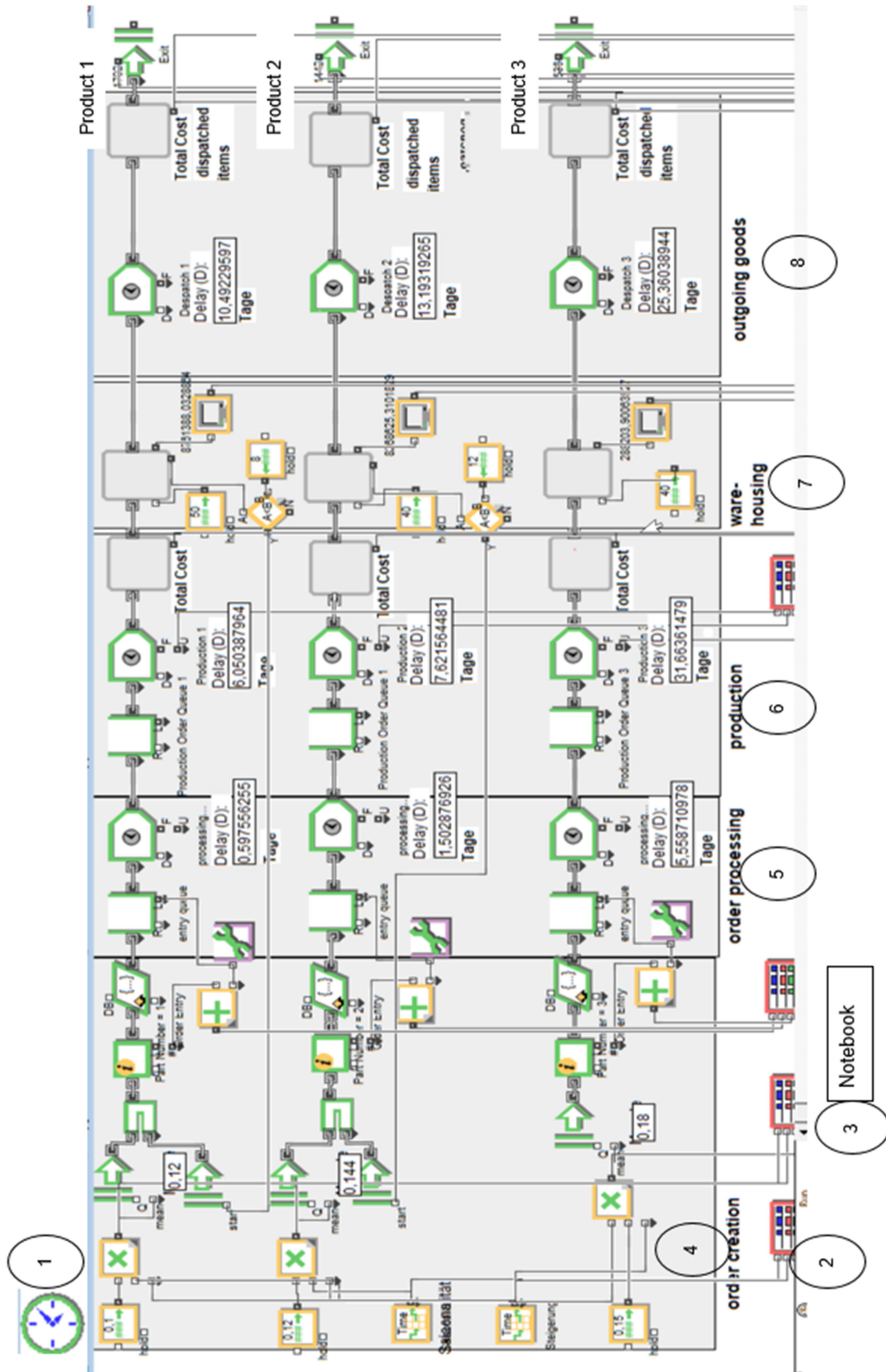

The model in Fig. 4.5 represents the relevant process steps started by order creation and then followed by order processing, production, warehousing and outgoing goods.

Each zone has a numeric label to add further explanations. Zone 1 shows an executive block which controls all discrete events in ExtendSim. Zone 2 represents the arrangement of various plotters to reflect modelling results. Additionally, a so-called Notebook in zone 3 enables an easy documentation of all simulation results. The results of the simulation are discussed in a separate section.

Zone 4: It is assumed that the customers are located in the UK. They are active in different industries and place order for three different products. Due to market volatility the orders are created randomly according to normal distribution, i.e. the frequency of order placement as well as the volume and type of product are not deterministic. The current supply chain assumes that the OEM places its orders at the local sales organisation. The simulated supply chain assumes that the OEM places its orders directly in the manufacturing plants via electronic data interchange (EDI). The costs for the IT infrastructure are considered in the model accordingly.

Zone 5: The existing order processing is undertaken by the local sales organisation in the country where the OEM is located. This means that the order is received electronically and the employee checks on order information like quantities, part numbers, requested delivery dates, but also takes action e.g. with engineering department if the ordered product is not out of the product portfolio and needs some customising work. The time for processing the order depends on the product which is ordered. As products 1 and 2 are considered as standard parts, the order can be processed very fast within one day. Product 3 on the other hand usually needs to be coordinated by a sales engineer due to special customer requirements and needs thus an order processing time between one to three weeks. After checking the customer order, another production order is created and forwarded to the appropriate manufacturing plant. The allocation of the manufacturing plant depends on the product ordered from the customer.

In the simulation it is assumed that the OEM does not order with the local sales organisation, but directly in the manufacturing plants. In order to process the order electronically further on, an investment is necessary for the installation of an EDI

connection from the OEM directly to the manufacturing plant. To have this investment only one time in case of several manufacturing plants, it is assumed that one plant takes over the lead for order processing and sorts and/or forwards the production order according to the part number ordered.

Zone 6: Both the existing and the simulated production process foresees that each manufacturing plant produces one only product type. A queue is implemented for the time until the production order will be executed.

Zone 7: In the warehousing zone, different queues for the storage of the products are implemented.

For the current supply chain, it means that the local warehouse of the sales organisation provides separate storage areas for the different products. In the simulation, the products are stored in the warehouses of the different manufacturing plants. This means that the warehouse of the sales organisation becomes redundant, on the other hand, sufficient capacity needs to be provided in the manufacturing plants.

Zone 8: Dispatch of the products is based on the confirmed delivery date to the customer. Therefore, an activity block for dispatch as well as a queue is considered in the process of outgoing goods. The current dispatch process comprises an individual process for each product in the sales organisation. With the change to direct delivery, the dispatch process is transferred to the manufacturing plant and thus no longer relevant in the sales organisation.

All influencing parameters and results are realised as input and output connectors. Relevant parameters of the blocks are stochastic order entry and replenishment lead time, order quantity as well as costs for inventory. If control parameters change due to an adaptation of the supply chain – for example – costs and/or lead times need to be changed accordingly for the simulation. By implementing plotters for relevant blocks, ExtendSim creates graphical outputs for the development of critical factors like costs for inventory.

All relevant results of the existing supply chain are summarised via the Notebook (zone 3) and discussed. The Notebook window is designed for the end users' facilitation and

can be drawn from any place of the model by using the cloning function and placing the ExtendSim block into the Notebook.

4.3.5 Relevant Costs for the Simulation

Based on the cost analysis in the sales organisation, the potential savings depending on the delivery option are derived and at the same time the investment in the relevant manufacturing plants are quantified. This means that based on the commercial evaluation a switch to direct delivery may be recommended.

Major changes were explored for the following types of costs:

- 1.) Order processing costs: The costs for order processing not only include costs for sales employees, but also costs for IT infrastructure like e.g. EDI connection. The EDI connection enables an accelerated data transmission of order information from the customer to the manufacturer. Additionally, costs are included for engineering staff, in case the customer requests a special product solution which is not part of the standard product portfolio. For simplicity reasons, administration costs for payables and receivables are also considered as part of order processing costs. The differentiation between fixed and variable costs is made as follows:

Fixed costs: All costs which remain constant independent of the production or sales output, e.g. salaries for sales engineers, offices and technical equipment.

Variable costs vary in dependence of production or sales output. In case if sales increases, additional travel expenses or other costs for office material will be generated.

- 2.) Production costs: These costs include costs for material, machines and staff. Costs may vary as e.g. heavy parts require additional cranes for carrying or transporting and lead to an increase in costs. Again, a distinction between variable and fixed cost is being made. Fixed costs include costs for the production facility as well as salaries for production engineers. Variable costs consider costs for material, energy as well as wages for workers.

- 3.) Warehousing costs: This position include all costs for inventory related to storing and maintaining.
- 4.) Dispatch costs: This position includes personnel costs for fulfilling the dispatch process, i.e. creation of shipment documents, transmitting electronic data to the forwarding agency, commissioning. Material expenditures may occur for barcode scanners which are used for inventory control.

For the cost calculation, all entities which are involved in the various options are considered, i.e. the actual cost in the sales organisation are analysed. The costs comprise all expenses which are related to the OEMs activities, e.g. all personnel costs, warehousing costs, freight costs and capital charges. A detailed overview of relevant costs is shown in Table 4.1, whereas the focus of the optimisation in the model is on variable costs. The order in Table 4.1 gives an indication about the magnitude of the costs, i.e. the top of the list means that the type of the cost is more valuable than the costs further down.

The research sheds light on all relevant factors which are important for the managerial decision. A simulated calculation was conducted and it clearly shows that savings for personnel costs and inventory can be achieved. Savings on the physical warehouse which is no longer in use for the sales organisation depend on the future use of it.

Even if the process of direct delivery as described in this case leads to an increase in information as such, which needs to be evaluated and managed by qualified people, the value out of this data enables possibility to implement a controlled material flow which results in benefits like reduced inventories, decreasing logistics costs and at the same time a stable or even improved customer satisfaction.

Table 4.1: Overview of relevant types of costs

Type of cost	Description
Inventory	costs for inventory related to storing and maintaining
Personnel cost	customer related personnel costs, e.g. sales, warehousing, engineering, claim mgt, controlling and finance
Capital charges	value which is tied up in assets
cost of receivables/payables	costs for managing receivables/payables
Stock obsolescence	write-offs of inventory
Structural cost	costs from other cost allocations
IT infrastructure	cost for additional IT architecture in order to automatize the information flow
cost for conversions/ internal repairs	cost for special product requirements or repairs
Scrap	cost for obsolete stock which is not saleable
Packaging costs	cost for special packaging, e.g. wooden boxes
Freight charges	freight costs, e.g. for internal freights
Price risk	price risk: does customer accept changes in price due to changes in supply chain process? (+/- x% of sales price)

Table 4.2 outlines the overview of variables as well as mathematical equations which are used for the model. Table 4.2: Overview of variables and mathematical equations

Variables	Description	Formula
$M_{c;t}$	Cost magn. cost c in iteration t	$M_{c;t} = M_{c;t-1} + R_{c;t} + P_{c;t} + I_{c;t} + S_{c;t}$
$M_{i;t}$	Cost magn. cost i in iteration t, influencing risk r	-
$R_{c;t}$	random evolution of cost c	$R_{c;t} = R_{c;t-1} * \text{Norm.Inv}(\text{SND}, 0, \text{SDV})$
$P_{c;t}$	Production replenishment of cost c	$P_{c;t} = \{0 \text{ for } t \in [0;250] \cup [271;500] \text{ TP}_c, \text{ for } t \in [251;271]\}$
$I_{c;t}$	Accumulation by all costs i on cost c	$I_{c;t} = \sum (\Delta \text{EQU}_{i;t} * \text{INT}_{c;i} / \text{DIV})$
$S_{c;t}$	Stabilization of cost c	$S_{c;t} = (M_{c;t} - \text{EQU}_c) / \text{RES}$
RND_t	Random number in iteration t	$\text{RND}_t = \text{Random}[0,1]$
$\Delta \text{EQU}_{c;t}$	Delta between cost magnitude c and initial equilibrium	$\Delta \text{EQU}_{c;t} = M_{c;t} - \text{EQU}_c$
$\Delta \text{EQU}_{i;t}$	Delta between cost magnitude i and initial equilibrium	$\Delta \text{EQU}_{i;t} = M_{i;t} - \text{EQU}_i$
EQU_c	Initial equilibrium of M_c	$\text{EQU}_c = M_{c;t=0}$
EQU_i	Initial equilibrium of M_i	$\text{EQU}_i = M_{i;t=0}$
SDV	Standard deviation of random evolution	$\text{SDV} \in \mathbb{R}^+$
$\text{INT}_{c;i}$	Strength of accumulation between cost i and c	$\text{INT}_{c;i} \in \{0;1;2;3\}$
DIV	Divisor accumulation strength	$\text{DIV} > 0; \mathbb{R}^+$
RES	Divisor stabilization strength	$\text{RES} \in \mathbb{R}^+$
TP_c	Trigger of replenishment	$\text{TP}_c \in [0,10]$

4.3.6 Relevant System Parameters

This section gives an overview of all relevant parameters of the status quo and how they will change in the simulation. They are processed in the simulation appropriately.

Product Mix can essentially be categorised in three product clusters, which are called “Go To”, “Standard” and “Others”. The distinctive feature is the delivery time. Based on the requested delivery time from the market, the product is grouped in one of the three categories. This means in this case study that “Go To”-products can be delivered in 5-7 days, “Standard”-products in 10-12 days and “Others” are delivered on request. While “Go To” products are rather series products with limited technical features, “Standard” products offer more functionalities which may require additional production steps. However, they are still not customised products. A product is assigned to a particular group based on the delivery time which is requested from the market. If a customer wishes additional specifications, the product belongs to “Others” and the delivery time has to be checked individually. For simulation purpose, all three product clusters are represented as “Product 1” (Go To), “Product 2” (Standard) and “Product 3” (Others). Based on the attractive delivery time for Product 1, it is assumed that the demand will increase rapidly. A similar behaviour can be expected for Product 2, as the customer may now rely on guaranteed lead times for a product with more technical features compared to Product 1. The product mix concentrates on three different products. A prerequisite for the short delivery time is that only a limited quantity of five pieces can be ordered and that consolidated deliveries – i.e. combination with other goods – are not possible.

Delivery time is measured from the time of order placement until time of dispatch.

Demand Behaviour in status quo as well as in the simulation ranges over 5 years and is random following a normal distribution. The mean is constant over time the standard deviation for product 1 is 20, product 2 is 30 and product 3 40. The normal distribution stretches over 5 years. Coefficient variation is defined as follows: product 1 $20/120$, product 2 $30/100$ 1.0 and product 3 at $40/80$.

Order Creation. Today, there are no restrictions when an order for a special product can be placed; therefore, the time of order creation for product 1, 2 and 3 is chosen randomly with normal distribution.

Order Processing is based on the First-In-First-Out method for status quo as well as for the simulation. However, it can be observed that the costs for order processing will perceive a cost increase in the simulation. This means that for product 1 and 2 the costs remain constant, while for product 3 costs will increase. The cost increase is justified by additional order processing capacity as well as for additional engineers which provide essential support for the customised products, especially for product 3. This is the reason why product costs for order processing increase from 6.7 in status quo by 10% in the simulation.

Production. Each product is allocated to a special production location. The production order corresponds to the order of incoming sales orders. Production costs in the status quo scenario are as follows: product 1 50, product 2 60 and product 3 78. With the future supply chain design, it is expected that production costs for product 1 decrease down to 45, for product 2 down to 52 due to economies of scale, e.g. consolidation of inventories and cost reduction in production. On the contrary, production costs for product 3 are expected to increase up to 85, as additional costs for personnel capacity is necessary to fulfil special customised products.

Warehousing and Outgoing goods. The queue method for this process is FIFO. Today, the product cost in the status quo is at 2.5% of the product value where costs for handling and storage are included. As the simulation foresees that the warehouse in Great Britain will be closed the existing costs remain unchanged due to available capacity in existing facilities at the manufacturer.

Costs. The technical simulation model offers the possibility to consolidate all process costs from order processing via production until inventory and dispatch.

Inventory Policy is R, Q. R, Q is a fixed replenishment quantity inventory policy. When the inventory level on-hand falls below a certain replenishment point, R, the site will generate a replenishment order for a certain quantity, Q, of this product. Q is determined via the daily consumption and the corresponding delivery time. When using

this policy, the Reorder Point field is set as the trigger level. The Reorder/Order up to Quantity field will be the exact number of units reordered.

The simulation works as follows: Each of three products contains individual attributes regarding costs, delivery time and demand. Data in terms of costs and inventories were provided by the controlling department and data regarding delivery times and product mix were provided by the logistics department. All data is anonymised due to confidentiality reasons. In the first step, a simulation is started to see the development of costs and performance based on the existing supply chain. According to managers' statements, these KPIs are important for the company's profitability as well as for its competitiveness. It considers the supply chain processes from order creation via order processing, production, warehousing and outgoing goods. The simulation provides insights into costs of warehousing, utilisation of production, but also total cost development. In a second step, the simulation is adapted according to the new supply chain design shown in Fig. 4.3. This means that applying direct delivery the attributes for costs and production utilisation will vary as described before. Both simulations have in common that the demand behaviour of customers remain identical and both simulations cover a time period of five years. As supply chain designs have to withstand to market dynamics like growing or shrinking markets, an appropriate simulation is included later in this paper.

Apart from these parameters, there are some other important parameters which cannot be quantified, but have to be considered for this strategic decision:

Market and customer requirements. As the OEM follows the claim to fulfil all customer requirements, many standardised products cannot be delivered in their original technical state, but rather they need further conversions before delivery. For example, software settings or drillings in a hydraulic power unit have to be adjusted to customer specifications. Such conversions are requested in about 80% of order lines. As these conversions are also manifold, a new definition of "standardized product" is very difficult. Orders are placed via a rolling electronic delivery schedule, i.e. a forecast based on product and quantity is given for the next 18 months. The closer the call-off horizon, the more binding are quantities and product types. It is very important for the planning of inventories to receive a regularly-updated schedule from the customer to avoid unnecessary inventory costs or disruptions in case of delivery bottlenecks. In

order to grant a high product availability, the customer tends to order more quantities, but calls off less so that the stock at the manufacturer is increasing. The CAGR based on sales volume increase of the past 5 years is assumed to be 20% for each product group for the next 5 years.

Internal organisation. Despite the transmission of electronic delivery schedules, employees from the manufacturer need to countercheck the delivery schedule. They conduct comparisons with previous order behaviour to avoid errors. As short-term adjustments of orders are received by email and not within the delivery schedule in the ERP system, employees need to observe this process manually to make sure that products are procured correctly. As each OEM has between 10 and 20 different customer numbers for the individual industry sectors, this process is very difficult and time-consuming. Additionally, technical engineers are dedicated for the customers in this research to coordinate the requested technical conversions. For the case of direct delivery, it has to be ensured, that the engineers are firm in English and understand the requirements also from a language perspective.

IT infrastructure. Compatibility of the IT systems is a very important premise for an automated ordering process. For the target process of direct delivery, the existing interfaces from the OEM to the sales organisation need to be transferred to the German plants. As sales organisations and plants are on different IT platforms due to their requests of core processes, this investment needs to be considered in the overall calculation for the decision. In order to ensure fast order processes and generate cost savings, automated processes in an ERP system and EDI connection are conditions for the switch to direct deliveries.

Freight costs. In this case, the agreed incoterm between manufacturer and customer is FCA (free carrier). This means that the customer nominates a carrier and informs the manufacturer about the carrier's name. Usually, the carrier picks up the delivery at the manufacturer's premises or at a different place which is specified. In case of changing the delivery process to direct delivery, it can be assumed that no further risk in terms of cost increase will occur for the manufacturer. However, if increased transportation costs will be generated through longer distances for the customer, it has to be considered that the customer may ask for any premium in the form of price reductions. This risk has to be taken into account for the decision of changing the delivery process.

Personnel costs. The investigation unfolds that overall eight employees are involved in customer service activities in the sales organisation, i.e. order processing and customer relationship, sourcing and warehousing. The potential for cost reduction foresees that 1-2 employees further support local customer relationship and all other activities for purchasing, material management and dispatch are covered by existing capacities in the German plants. This means that personnel costs in the plants remain on a constant level, but personnel costs in the sales organisation decrease.

Warehousing. During the research project the two customers under study needed warehouse space for their products of approximately 2000 m² at the premises of the sales organisation. In case of direct delivery to the customers this area would be at any disposal. As the target is not to increase inventory in the sales organisation, the warehouse could not be used at its original purpose and causes at least remaining costs for depreciation or maintenance. As the plants could provide the space capacity which is needed in case of direct delivery, no further costs will occur for the German plants for additional space.

General risks. As the customers request and receive a very high customer service level in this case and are also very important for the growth of the manufacturer, this high service level needs to be guaranteed also in future. A change to direct delivery can only be conducted if the service from the German plants is ensured for the future and tested in advance. However, the unpredictable factor is the price. Provided that the service can be ensured, the customer will probably agree to direct delivery. As this change will lead to cost savings for the manufacturers, the customer will also demand to participate from the cost savings through price reductions.

These options are the basis for further cost calculations and finally the basis for the managerial decision. Regarding the cost calculation, all three options are quantified to identify potentials for cost savings and implement a cost-efficient process. However, despite the pressure on the cost side, the managerial decision depends also on strategic aspects like sales growth with the customer or other risks e.g. assurance of delivery performance or price risks due to changes in the process.

4.4 Scenario Analysis

4.4.1 Comparison Status Quo vs. Simulation

Postma et al. (2005) argue that scenario analysis is able to support the management of strategic decisions, especially in terms of dealing with uncertainties that confront the future of business organisations. Both practitioners and academics claim scenario analysis as effective methodology for problems in different surroundings. In this section, scenario analysis is applied to explore the robustness of the aligned supply chain as well as in case of growing and shrinking market demand. The scenario analysis is typically organised in an input and output framework (Swart et al., 2004). The purpose of the scenario analysis is to propose supply chain alignment with different impact on costs and inventories.

Inventory. Based on the order entry behaviour and the product characteristics, Table 4.3 shows the evaluation per product for inventory costs per status quo and after the simulation which considers the redesign of the supply chain. The table gives an overview of key data after five years. In order to satisfy short lead times for product 1, stock is prepared in high quantities which causes highest inventory costs in comparison to product 2 or 3. As product 3 is a customised product and typically “made-to-order”, inventory costs develop at a low level.

Table 4.3: Average inventory per product (in TEUR)

	Year 1		Status quo vs. Simulation in %	Year 2		Status quo vs. Simulation in %	Year 3		Status quo vs. Simulation in %
	Status quo	Simulation		Status quo	Simulation		Status quo	Simulation	
Product 1	600	556	-7,3	718	650	-9,5	830	720	-13,3
Product 2	680	620	-8,8	761	714	-6,2	864	802	-7,2
Product 3	1.500	1.356	-9,6	1.567	1.421	-9,3	1.654	1.432	-13,4
Total	2.780	2.532	-8,9	3.046	2.785	-8,6	3.348	2.954	-11,8

	Year 4		Status quo vs. Simulation in %	Year 5		Status quo vs. Simulation in %
	Status quo	Simulation		Status quo	Simulation	
Product 1	950	802	-15,6	1.171	843	-28,0
Product 2	1.063	921	-13,4	1.213	1.087	-10,4
Product 3	1.732	1.503	-13,2	1.844	1.699	-7,9
Total	3.745	3.226	-13,9	4.228	3.629	-14,2

Although an absolute inventory increase can be observed from year to year due to consolidation of warehouses which arise from the redesign of the supply chain, a relative inventory decrease can be presented in comparison to the supply chain as per status quo. With the change to direct delivery, average inventory costs over all three products can be reduced by ca. 9% after the first years. After five years, inventory costs can be reduced by approximately 14%. The largest contribution results from the fast-moving product 1. As product 1 is characterised by short delivery dates of few days which is buffered through lots of inventory in many warehouses, savings of 28% can be achieved through central warehousing. Customers can now directly be served out of the manufacturer's warehouse. In comparison to product 1 and 2, product 3 is categorised as customised product and thus generates higher absolute inventory costs for the following reasons: (1) high product value, (2) product complexity (many different parts) and consequently (3) longer storage in the warehouse until final assembly. Even product 3 will no longer be assembled in the location of the sales organisation, but rather directly at the manufacturer's premises in Germany. This simulation gives clear evidence that the redesign of the supply chain to direct delivery will reduce inventory costs.

Logistics costs. After having analysed the development of inventories after the supply chain's redesign, this research explores also the development of logistics costs. Table 4.4 depicts the development again as per status quo and simulation for five years. The definition of logistics costs has already been discussed and its quantification in this case study is now shown. Each process of the supply chain model contains a defined cost rate which has been analysed in advance. Data has been provided from controlling managers, i.e. that the specific costs from the plants in Germany as well as the UK were collected from monthly reports for further evaluation. This evaluation reflects the cost situation per resale in the existing supply chain and is the basis for the comparison of the cost development per direct delivery. For simplicity reasons, logistics costs in Table 4.4 show costs for all three products in one total.

Table 4.4: Average logistics costs (in TEUR)

	Year 1		Status quo vs. Simulation in %	Year 2		Status quo vs. Simulation in %	Year 3		Status quo vs. Simulation in %
	Status quo	Simulation		Status quo	Simulation		Status quo	Simulation	
Product 1	600	556	-7,3	718	650	-9,5	830	720	-13,3
Product 2	680	620	-8,8	761	714	-6,2	864	802	-7,2
Product 3	1.500	1.356	-9,6	1.567	1.421	-9,3	1.654	1.432	-13,4
Total	2.780	2.532	-8,9	3.046	2.785	-8,6	3.348	2.954	-11,8
Sum of log cost w/o inventory	410	382	-6,8	423	393	-7,1	435	404	-7,1
Logistics costs	3.190	2.914	-8,7	3.469	3.178	-8,4	3.783	3.358	-11,2

	Year 4		Status quo vs. Simulation in %	Year 5		Status quo vs. Simulation in %
	Status quo	Simulation		Status quo	Simulation	
Product 1	950	802	-15,6	1.171	843	-28,0
Product 2	1.063	921	-13,4	1.213	1.087	-10,4
Product 3	1.732	1.503	-13,2	1.844	1.699	-7,9
Total	3.745	3.226	-13,9	4.228	3.629	-14,2
Sum of log cost w/o inventory	448	417	-6,9	461	429	-7,0
Logistics costs	4193	3643	-13,1	4689	4058	-13,5

In general Table 4.4 gives evidence that the OEM may expect savings in logistics costs after redesigning the supply chain. In the fifth year, logistics costs can be reduced by ca. 14%. Although part of the reduction results from the inventory effect which has been discussed before, another cost reduction can be seen in other cost types of logistics costs. Cost reductions can be achieved by shifting personnel in engineering, sales and warehousing. Synergies can be realised at the OEM's plants in Germany, where parts of product 1, 2 and 3 are produced anyway. While product 1 and 2 are series and standard products, no remarkable cost increases are considered due to the supply chain redesign. This looks different for product 3 which requires intense customer consulting. Here additional overhead costs have to be taken into consideration for the direct delivery process. It can be summarised that the reduction in costs leads to a reduction of complexity, because material and information flows can be consolidated directly at the OEM plants in Germany. Of course, all costs need to be analysed in detail via the simulation model to come to a conclusion of adapting the supply chain. The model

which is developed in this research offers managerial support for making supply chain decisions and contributes to academic discussions for supply chain designs.

4.4.2 Model Verification

Model calibration. The model is calibrated as provided in literature (Guertler et al., 2015). It is started with the formulation of the system characteristics which have to be considered in the simulation model. Before the model is tested against the characteristics, all constants or parameters are calibrated which have not yet been adjusted. This refers to “Standard Deviation of random evolution” SDV, “Divisor accumulation strength” DIV, and “Divisor stabilization strength” RES. The calibration can be formulated ensuring that potential errors are not hidden by too many calibration handles (Oliva, 2004). In order to achieve model confidence and obtain all required characteristics, an iterative calibration approach is chosen as shown in Table 4.5.

Table 4.5: Calibration scheme of the DES model:

Step	Vari-ables	Description	Effect
#1	SDV	Balance with RES	Increasing the standard deviation SDV adds a random evolution of risk magnitude to the system characteristics as required by characteristic (5). Reducing the divisor stabilization strength RES compensates for an increased SDV to maintain the system's ability of self-stabilization as required by characteristic (4).
#2	RES	Balance with SDV	
#3		Proceed to step #4, if RES and SDV are balanced; if not go back to step #1	Reducing DIV ensures that interrelationships are in comparison to the increased random evolution still adequately considered as required by characteristic (2).
#4	DIV	Reduce to a level where characteristic (2) is achieved and (3) not yet lost	The increase must be small enough to not lose the system's stability as required by characteristic (3).
#5		Check system behavior and go back to step #1	

In calibration step #1, the standard deviation SDV is increased to add random evolution of risk magnitude to the system as required by characteristic (5). Next, in step #2 the divisor of the stabilisation strength RES is reduced to compensate for an increased SDV and maintain the system’s ability of self-stabilisation as required by characteristic (4). The adjustment of both system variables SDV and RES has to be balanced, which is checked in step #3. In step #4, DIV is reduced which increases the effect of interrelationships within the system. This is performed down to a level, at which interrelationships are – in comparison to the increased random evolution SDV – adequately considered as required by characteristic (2). However, the increase must be

sufficiently small to avoid jeopardising the system's stability as required by characteristic (3). Step #5 finally reviews whether the system's behaviour is in line with all required characteristics to decide whether to restart or end the optimisation process. Finally, the desired system behaviour is obtained under the following constant values:

SDV: 0.1, DIV: 100, Res: 6.5 iterations.

Model validation. Literature (Gass 1983, Sargent, 2013) argues that simulation models are used for a variety of purposes such as in the design of systems, in the development of system understandings. The users of these models, the decision-makers use information received from the results of these models, and the individuals affected by decisions based on these models are well concerned with whether a model and its results are "correct" for its use. This concern is addressed through model verification and validation. Model verification is defined as "ensuring that the computer program of the computerized model and its implementation are correct". Model validation is defined as the "substantiation that a model within its domain of applicability possesses a satisfactory range of accuracy consistent with the intended application of the model" (Gass, 1983). Sargent (2013) offers different validation techniques like comparison to other models, extreme condition test, internal validity data relationship correctness or multistage validation. In general, a combination of techniques can be used. These techniques are applied for the verification and validation of the model. In this research the model is verified and validated by a sensitivity analysis which represents values of a growing and shrinking market.

Growing Market. Grand View Research (2015) argues in its construction equipment market forecasts to 2020 that rapid urbanisation and infrastructural growth have increased the construction equipment industry over the past years so that the segment of earth-moving machinery and construction equipment is predicted to grow at an CAGR of 5.7% by 2020. Based on the assumption of increasing market demand, the simulation is run to explore the effects for cost development. By transferring the assumption of a growing market through increasing demand, the model simulates the total cost development through an increase of order entries. The assumption further includes that all other costs for processes in the supply chain remain stable. Table 4.6 shows the result of logistics cost development in case of increased demand. Compared to the logistics costs in Table 4.4 it can be said that the order of products in terms of costs does

change, i.e. that customised products cause the lowest costs, followed by the “Go To” product and then the “Standard” product. However, accumulating the costs of all three products and comparing them to the existing supply chain, it can be argued that aligning the supply chain offers the potential for cost savings. The analysis of the simulation shows that this approach would be successful.

Based on data from the controlling manager of the OEM, it is assumed that in case of growing sales by 20%, inventory will increase by 8%. The increase is taken from years when actually a sales increase of 20% could be reported. The other important cost type of logistics costs derives from personnel costs and are considered as fixed costs. Therefore, the remaining logistics are presumed to remain unchanged.

Table 4.6: Development of logistics costs in case of growing market

	Year 1		Status quo vs. Simulation in %	Year 2		Status quo vs. Simulation in %	Year 3		Status quo vs. Simulation in %
	Status quo	Simulation		Status quo	Simulation		Status quo	Simulation	
Product 1	600	600	0,1	718	702	-2,2	830	778	-6,3
Product 2	680	670	-1,5	761	771	1,3	864	866	0,3
Product 3	1.500	1.464	-2,4	1.567	1.535	-2,1	1.654	1.547	-6,5
Total	2.780	2.735	-1,6	3.046	3.008	-1,3	3.348	3.190	-4,7
cost w/o	410	382	-6,8	423	393	-7,1	435	404	-7,1
Logistics costs	3.190	3.117	-2,3	3.469	3.401	-2,0	3.783	3.594	-5,0

	Year 4		Status quo vs. Simulation in %	Year 5		Status quo vs. Simulation in %
	Status quo	Simulation		Status quo	Simulation	
Product 1	950	866	-8,8	1.171	910	-22,3
Product 2	1.063	995	-6,4	1.213	1.174	-3,2
Product 3	1.732	1.623	-6,3	1.844	1.835	-0,5
Total	3.745	3.484	-7,0	4.566	3.919	-14,2
cost w/o	448	417	-6,9	461	429	-7,0
Logistics costs	4193	3901	-7,0	5028	4348	-13,5

Compared to the supply chain of the status quo, the simulation shows costs savings for each year in case of growing market. Cost savings in year 1 and 2 are lower, because the realisation of savings in fixed costs can be realised only after year 3. This scenario represents validity of the redesign of the supply chain.

Shrinking Market. In the past, nearly all OECD countries have suffered a decline in GDP, trade flows as well as an increase in unemployment due to the global economic crisis in 2009. Export volumes of the G7 countries fell by 13.6% in 2009 and world trade volumes were expected to fall even by 16% (OECD, 2009). Such an economic crisis generated by a severe decrease in demand may have negative implications for long-term economic growth and represent a risk to global supply chains that enforce innovation. These supply chains are critical resources of knowledge for companies, as they provide firms with technical expertise, knowledge of foreign markets, business contacts and international partners (OECD, 2009). Based on this assumption, the simulation shows the effects on costs in an aligned supply chain in case of shrinking market conditions, i.e. the model validates the total cost development with decreasing order entries; product mix and prices are expected to remain stable. Less costs occur for product 3, followed by product 1 and product 2. Again, in the case of crisis the adjusted supply chain with direct deliveries offers more potential in terms of cost savings than the existing supply chain. The analysis of the simulation in case of shrinking market conditions does also support the validity of the model. Table 4.7 shows simulated figures over a period of five years in case of shrinking market. Again, cost savings can be achieved with the redesign of the supply chain.

Table 4.7: Development of logistics costs in case of shrinking market

	Year 1		Status quo vs. Simulation in %	Year 2		Status quo vs. Simulation in %	Year 3		Status quo vs. Simulation in %
	Status quo	Simulation		Status quo	Simulation		Status quo	Simulation	
Product 1	570	528	-7,3	682	618	-9,5	789	684	-13,3
Product 2	646	589	-8,8	723	678	-6,2	821	762	-7,2
Product 3	1.425	1.288	-9,6	1.489	1.350	-9,3	1.571	1.360	-13,4
Total	2.641	2.405	-8,9	2.894	2.646	-8,6	3.181	2.806	-11,8
cost w/o	410	382	-6,8	423	393	-7,1	435	404	-7,1
Logistics costs	3.051	2.787	-8,6	3.317	3.039	-8,4	3.616	3.210	-11,2

	Year 4		Status quo vs. Simulation in %	Year 5		Status quo vs. Simulation in %
	Status quo	Simulation		Status quo	Simulation	
Product 1	903	762	-15,6	1.112	801	-28,0
Product 2	1.010	875	-13,4	1.152	1.033	-10,4
Product 3	1.645	1.428	-13,2	1.752	1.614	-7,9
Total	3.558	3.065	-13,9	4.566	3.448	-24,5
cost w/o	448	417	-6,9	461	429	-7,0
Logistics costs	4006	3482	-13,1	5028	3877	-22,9

4.5 Findings and Managerial Implication

In the simulation it is analysed how costs change by reducing complexity over the supply chain. The reduction of complexity is defined by aligning the supply chain towards the customer, i.e. the existing sales organisation as the “wholesaler” of the supply chain is eliminated and the customer can now order directly in the manufacturing plant. This change in the supply chain is a valuable contribution of how a complex supply chain can be adapted. Even if costs and production utilisation are affected by this process change, the simulation shows that inventory and logistics costs decrease, although further investments in overheads for engineering have to be considered. A remarkable investment are costs for the IT infrastructure to implement an EDI connection for automatic order processing. Additional trainings for employees are necessary to handle the specific customer orders. These additional costs are considered for the adapted supply chain. The results of the simulation provide evidence that in this case cost savings can be realised and production can also be utilised to a greater extent. Therefore, this research provides support when adapting supply chains. It gives managers guidelines for entrepreneurial decisions if an existing supply chain can be switched to direct delivery or not. In order to validate the model, two further scenarios are simulated. The first one considers a growing market by assuming an increase in demand and the second one a shrinking market with appropriate decrease in demand. Both scenarios cover situations from a business cycle which managers have to cope with. As these changes in demand are in line with the previous results, the model can be applied for similar cases. Of course, it is important to consider all relevant cost types and their development in case of a redesign. While much progress has been made in

optimising supply chains (Garcia et al., 2015), there is still a great need for efficient approaches to deal with complex supply chains and adapt and align them. As in every study also this research has its limits. Although the simulation is conducted for a complex supply chain, it first concentrates to the data of one manufacturer out of the machine construction industry only. Further, the focus of the simulation is on selected KPIs like costs and production utilisation. For future research it is recommended to explore the model's behaviour in other industries and look deeper into complexities of manufacturers. For example, the model could be modified to variations of storage capacities or changes in demand. With the DES, managers are now able to decide how effective the redesign of their supply chain can be realised.

4.6 Conclusion

In Chapter 4, a DES model is developed to explore effects for costs, inventory and production utilisation for a supply chain that is changed from resale to direct delivery process. Chang et al. (2001) argue that DES enables a prior evaluation of a potential scenario for the following reasons:

- 1.) it enables companies to perform powerful what-if analyses leading them to better planning decisions;*
- 2.) it permits the comparison of various operational alternatives without interrupting the real system and*
- 3.) it permits time compression so that timely policy decisions can be made.*

The model in this research paper simulates an alternative supply chain for an OEM customer in the machine construction industry. In order to receive reliable results, comprehensive data on customer order behaviour, costs and processes is necessary to create the simulation model. The model is applied to a case study to estimate the logistics costs as well as inventory development throughout the supply chain.

The simulation model introduced in this manuscript could be used as a decision support tool to evaluate modifications in existing supply chains and design new chains.

Literature (Lee et al., 2002, Tako et al., 2012, Persson et al., 2009) highlights that DES is useful for decision support management like supply chain design or inventory planning and management. By creating a DES model, it can be seen how the system changes, when costs change due to relocations in the supply chain or changes in order processing. The outputs of the model could be used in conducting feasibility analysis, risk analysis, and life cycle analysis on the given supply chain. The model considers changes in costs which are caused through changes in the supply chain process. Further the model is validated by simulating the cost development in case of a growing as well as shrinking market.

The obtained results from the simulation model could be more accurate if improved functional relationships were used for each operation. For instance, the effects of using different types and quality of raw material on the performance of the equipment are not considered in the model since the required data were not available. Therefore, by developing functions that represent the relationship between the performance of each piece of equipment and the type of raw material used in the process, it would be possible to improve the precision of the results. Additionally, the sources of uncertainties or number of products in the real system are not limited to those considered in this study. Providing more data on the input parameters could further increase the reliability of the outputs of the model. This research paper analysed an aligned supply chain including effects on KPIs. The case is based on a real business case and prepared a simulation of what happens if the existing supply chain is aligned. The result shows cost savings for inventory, personnel and handling costs.

However, the case does not investigate the customer behaviour. The savings can only be realised if the customer agrees and accepts the process changes in terms of direct delivery. It is unclear how the customer will negotiate the investigated conditions. This research suggests that it can be useful for companies that face high levels of inventory to examine processes or supply chain models to reduce inventory. The given paper has shown the possibility of using the ExtendSim 9 package for the simulation of an aligned supply chain by adapting the existing resale process to a direct delivery process, characterised by a random demand for the product and random time of product delivery. The main advantages of the considered simulation method of inventory control problems solving are as follows:

- the clarity of the presentation of results; first, it touches the case of analysis of total expenses dependence on one control parameter with fixing others;
- the possibility of finding optimal solution of an inventory problem in the case when realisation of analytical model is rather difficult;
- a descriptive user interface, and ability to control any necessary parameter.

The developed model can be used for analysing the dynamics in inventory as well as for the dynamics in costs. The result is a valuable contribution for making managerial decisions and enriches academic research in the field of SCC and/or DES. Future research is recommended in the area of multi-product inventory systems, but also by exploring comparable supply chains in other companies to increase understanding and validity. This research presents insights into new drivers of SCC, but also on requirements of a supply chain.

5 Summary and Outlook

5.1 Summary

Global supply chains represent an outstanding competitive advantage for globally-acting companies. For competitive reasons, manufacturers are forced to use cost advantages for raw materials or workforce from different places all over the world, but satisfy their customers with high quality, short delivery times and reasonable costs. All benefits of globalisation which attract manufacturers lead at the same time to an increase of SCC, due to the challenge of managing information and material (Mentzer, 2001).

In this dissertation, the reasons for an increase of SCC and its behaviour have been investigated. It could be observed over recent years that markets have become more volatile (IHS, 2014), whereby companies are forced to align their global supply chains accordingly to maintain or improve their financial performance.

In Chapter 2, a qualitative research is undertaken in order to explore more about the phenomenon of SCC and thus to contribute to academic research. As the machine constructing industry plays a major role in German industry, an international company out of this sector is chosen for further research. A major benefit is given by the fact that not only the manufacturer is analysed in terms of SCC, but also representatives of the upstream and downstream supply chain, i.e. suppliers and customers. This approach enabled an in-depth information and results on SCC. At the same time, not only senior managers from logistics participated in the research, but also from sales, purchasing or engineering. This process ensures that a cross-functional perspective is considered for managing problems of SCC.

In Chapter 3, the requirements of a supply chain are explored. Even if manufacturers are confronted by an increase of SCC, agility is very important for their competitive business performance as well as being responsive to the market. Many activities are undertaken to improve agility, e.g. through IT integration which increases SCC on the other hand (Swafford et al., 2008). Lee (2004) defines three qualities of a top-performing supply chain: supply chain agility, supply chain adaptability and supply chain alignment. In this dissertation, the three mentioned qualities are further explored

in an international company out of the machine construction industry. It is analysed which activities are undertaken to support the three supply chain qualities and how these activities influence managerial KPIs like inventory costs, delivery performance or lead times. The research supports Lee's findings and extends his findings by creating a link to the impact of KPIs.

After having qualitatively explored SCC and supply chain agility in the previous chapters, a DES is conducted in Section 4 to quantify effects of inventory costs and logistics costs. For this reason, a supply chain model is created to show all relevant supply chain steps, i.e. from order creation and processing via production until outgoing goods. In order to reduce SCC, the simulation demonstrates the effects if the customer places its order directly in the manufacturing plant and no longer via the sales organisation in his country as it is done today. These changes include changes in costs and lead times. With help of the simulation, managers are able to decide if the alignment of the supply chain is beneficial or not.

These findings provide a comprehensive analysis and overview of the effects of SCC in dynamic environments in both the upstream and downstream supply chain. Apart from managerial implications, this research offers also valuable contribution for literature. For example, existing definitions (Jacobs et al., 2011) of SCC are reviewed and a topical one is offered in Chapter 2. Further, new drivers of SCC are explored based on the case study. These drivers have not yet been addressed in existing literature (Bode et al., 2015; Serdarasan, 2013; Seuring, 2004). This research extends also the work of Lee (2004) on the so-called triple-A. Literature (Prater et al., 2001; Braunscheidel et al., 2009) called for additional research on supply chain agility, supply chain adaptability and supply chain alignment. The present case study extends existing research by exploring the interdependencies of the three mentioned characteristics in Chapter 3. In order to fulfil the need to identify performance measures (Lee, 2004; Yusuf et al., 2014; Dubey et al., 2017), this research provides more details on operative and strategic KPIs in the context of the famous triple-A in Section 3.4. Finally, based on the research results on SCC as well as on Supply Chain Agility, Adaptability and Alignment, a DES model is proposed in Chapter 4 which could not be found in literature to date. This model considers topical requirements and drivers of a supply chain so that this research extends existing literature on simulation models (Grossmann, 2012; Chopra et al., 2012;

Barbosa-Pavoa, 2014). The model gives evidence on the reduction of inventories and logistics costs by redesigning the supply chain. Nevertheless, this field of research in terms of both industry and approaches as well as methodology offers plenty of areas of future research as outlined in Section 5.2.

5.2 Outlook

Based on the findings in this dissertation, various research questions on SCC could be answered. By conducting a case study in a globally-acting company, qualitative findings contribute to extend literature about the phenomenon of SCC. In order to gain a broad insight into this matter, senior managers from different organisational functions were interviewed. As supply chain managers are increasingly faced by SCC, they are now able to set priorities in their decision-making. The research further contributes to the ongoing academic discussion on SCC by exploring the understanding of it and its drivers from a managerial perspective. It resolves the existing limitations first by delivering a description and definition of SCC resulting from a case study, second by investigating how product variety influences SCM and the risk of uncontrolled complexity drivers and third by exploring practical measures to cope with drivers of detailed and dynamic SCC.

While complexity in SCM further increases and dynamics e.g. customised products with short delivery times also accelerate, the research on qualities in terms of supply chain agility, supply chain adaptability and supply chain alignment provides valuable contribution on this emerging field. This dissertation increases academic and managerial understanding of advanced SCM by exploring how supply chain agility influences supply chain partners. The research ascertained that with increased supply chain agility, improvements can be achieved for order fulfilment, but also for inventories, i.e. cost savings. The research made clear that it is not only speed as decisive success factor, but also the competence to answer to supply chain requirements, speaking of supply chain adaptability. The research elaborates on which KPIs these qualities have an effect on. Accordingly, it can be said that increased supply chain agility as well as supply chain adaptability provide competitive advantages. With the third quality – supply chain alignment – changes in the supply chain design under involvement of further supply

chain partners offer great potential for cost savings. Supply chains are often seen as chance for cost savings and value contribution. Therefore, the management of interfaces in the network is quite critical. This finding is confirmed by creating a simulation model in Chapter 4 of this dissertation. The approach of the simulated aligned supply chain can only be successful if the IT infrastructure is tailored according to the supply chain requirements. Additionally, personnel capacities have to be provided and trained to realise customer specifications and requirements. The manufacturer in the case study intends to align the supply chain to customer behaviour so that service improvements can be realised at lower costs. This adaptation inheres changes in processes and costs as well. With help of a DES it could be ascertained that aligning the supply chain actually leads to a cost advantage due to scales in the process of production, but also warehousing and dispatch.

Accordingly, value can be created so that prices can either be reduced (depending on competitive cost pressure) or profits can be increased. Definitely, there are many barriers which are relevant for a successful alignment, starting with a high level of transparency and visibility across supply chains. In addition to the above, extending analyses about SCC to further countries, markets or products represent an area for future research. While many results shown in Chapter 2, 3, and 4 can be generalised, the detailed results out of the simulation depend on managerial strategies as well as on customer behaviour. For example, if an important customer with high sales volume is not willing to accept an adapted order process e.g. for engineering reasons, the result will look differently. Based on the results of these chapters and literature from Lee (2004) – to name only one – it could be attempted if SCC varies in different regions and how supply chain agility is understood there. A more detailed simulation with a different simulation methodology could deliver new information.

If companies want to deliver sustainable operational and financial performance, they are requested to align their capabilities, strategies and customer relationships. It seems that there are only very few organisations in the world that have managed this challenge.

APPENDIX to Chapter 2

In-depth Interview

(Semi-structured style)

=====

Position:

Interview guide for the evaluation of complexity problems and challenges

Please answer the questions openly and honestly. If you have any questions, do not hesitate to ask. Your data will of course be treated confidential and will only be used for this empirical study.

A. Management of Supply Chain Complexity

1. What do you associate supply chain complexity with?

2. How much does supply chain complexity influence you and your business in the future?

1	2	3	4	5	6	7
---	---	---	---	---	---	---

1 = very significantly, 6 = very little, 7 = no comments

3. What is your opinion on how well your company is managing its supply chain complexity?

4. In which way are you confronted with supply chain complexity?

5. What problems do you see in the complexity of the supply chain?

6. What do you think is particularly good when managing your part of the supply chain complexity?

7. What do you think is particularly bad when managing your part of the supply chain complexity?

8. In your opinion, what is the expected outcome of a reduction of supply chain complexity?

9. "I take care of support or work in supply chain optimization projects....."

- regularly
- once in a while
- seldom
- never
- no comments

10. What do you think could help to further improve your supply chain complexity?

11. What is the expected profit of a reduction of supply chain complexity?

12. How important do you think are the following characteristics for a successful supply chain complexity management?

	1	2	3	4	5	6	7
Strategic fit (effective/responsive)							
Development of direction and speed							
Common culture							
Strategic interest							
Power distribution							
Integration of suppliers/customers							
Understanding of the customer and the supply chain							
Commitment/Trust							
Transparency							
Communication							
Benefit sharing							

1 = very important, 6 = unimportant, 7 = no comments

13. What do you think is working particularly well with respect to supply chain complexity?

14. Where do you see major problems?

15. What are the biggest challenges in your opinion when installing a supply chain complexity measuring system which includes the external supply chain?

16. How important is it to learn from suppliers/customers to improve the supply chain complexity?

1	2	3	4	5	6	7
---	---	---	---	---	---	---

1 = very important, 6 = unimportant, 7 = no comments

17. What kind of problems do you see with improvement efforts on supply chain complexity?

18. Being highly flexible means a professional management of uncertainties. What kind of problems do you see with flexibility resulting from supply chain complexity?

19. Which measures do you use to manage supply chain complexity?

20. How can the problems with flexibility in supply chain complexity be overcome?

B. Measurement of Supply Chain Complexity

21. Why should such a supply chain complexity measurement system be installed?

- 1.
- 2.
- 3.
- 4.
- 5.

22. Which key performance indicators do currently measure supply chain complexity?

- 1.
- 2.
- 3.
- 4.
- 5.

23. Do you think measuring the supply chain complexity can help you manage the supply chain?

Yes, why:

No, why:

24. Would you separate the complexity measurement into internal and external supply chain complexity, or consider it a single system for the entire supply chain?

Internal/external, why:

One system, why:

25. What kinds of measures do you use?

- Cost measures
- Quality measures
- Time measures
- Non-quantitative measures

26. Considering your system of internal supply chain complexity, how well do you think it supports your decision making like changes in processes or capacity planning?

1	2	3	4	5	6	7
---	---	---	---	---	---	---

1 = very well, 6 = very poorly, 7 = no comments

27. Do you have external complexity measures for your supply chain?

Yes, which ones: _____

No, why not: _____

28. Considering your system of external supply chain complexity measures, how well do you think it supports your management activities?

1	2	3	4	5	6	7
---	---	---	---	---	---	---

1 = very well, 6 = very poorly, 7 = no comments

29. What do you think is working particularly well?

30. Where do you see your major problems?

31. Do you agree that measuring the external supply chain complexity is important in order for a company to be competitive in the future?

1	2	3	4	5	6	7
---	---	---	---	---	---	---

1 = totally agree, 6 = totally disagree, 7 = no comments

32. What models for measuring the supply chain complexity are you familiar with?

33. Do you believe that new models like SCOR-model or the extension of such existing models as the balanced scorecard, can help you to measure your supply chain complexity?

1	2	3	4	5	6	7
---	---	---	---	---	---	---

1 = totally agree, 6 = totally disagree, 7 = no comments

Why do you think so?

34. What characteristics are very important to you for an excellent supply chain complexity measurement system?

	1	2	3	4	5	6	7
Accuracy							
Visibility							
Facilitates trust							
Easy to understand							
Encourages appropriate behaviour							
Measures only what is important							
Measures are quantitative							
Measures are defined and mutually understood							
Measures are multidimensional							
Encompasses both in- and outputs							
Others like:							

1 = very important, 6 = unimportant, 7 = no comments

35. Do you think your suppliers/customers would be willing to participate in a supply chain complexity measurement project?

1	2	3	4	5	6	7

1 = entirely willing, 6 = not willing, 7 = no comments

36. What is necessary, from your point of view, to incentivise suppliers/customers to participate?

37. Do you think measuring the complexity in the supply chain is complex?

1	2	3	4	5	6	7

1 = totally agree, 6 = totally disagree, 7 = no comments

Why do you think so?

38. How can the complexity in the measurement of the supply chain complexity be overcome?

39. Would you be willing to share sensitive data with a supplier/customer to improve the supply chain complexity?

1	2	3	4	5	6	7
---	---	---	---	---	---	---

1 = entirely willing, 6 = not willing, 7 = no comments

40. How can problems with data-sharing in supply chain complexity be overcome?

41. Do you see other problems occurring when measuring the supply chain complexity?

Thank you for your participation!

The results will be kept confidential and will only be used for this dissertation, as mentioned in the beginning.

APPENDIX to Chapter 3

In-depth Interview

(Semi-structured style)

=====

Position:

Interview guide

Please answer the questions openly and honestly. If you have any questions, do not hesitate to ask. Your data will of course be treated confidential and will only be used for this empirical study.

Research topic 1: Supply chain agility

Target: Respond to short-term changes in demand or supply quickly (Lee, 2004)

1. What do you associate supply chain agility with?

2. How much does supply chain agility influence you and your business in the future?

1	2	3	4	5	6	7
---	---	---	---	---	---	---

1 = very significantly, 6 = very little, 7 = no comments

3. What is the expected profit of an increase of supply chain agility?

4. What do you think is the expected risk of supply chain agility?

5. Which activities does your company realize or intend to realize in order to increase supply chain agility?

6. What is necessary/important to create an agile supply chain?

--

7. How do you measure supply chain agility?

8. What problems do you see in the agility of the supply chain?

9. What kind of problems do you see with agility resulting from supply chain complexity?

Research topic 2: Supply chain adaptability

Target: Adjust supply chain design to accommodate market changes (Lee, 2004)

10. What do you associate supply chain adaptability with?

11. How much does supply chain adaptability influence you and your business in the future?

1	2	3	4	5	6	7
---	---	---	---	---	---	---

1 = very significantly, 6 = very little, 7 = no comments

12. What is the expected profit of an increase of supply chain adaptability?

13. What do you think is the expected risk of supply chain adaptability?

14. Which activities does your company realize or intend to realize in order to increase supply chain adaptability?

15. What is necessary/important to create an adaptable supply chain?

16. How do you measure supply chain adaptability?

17. What problems do you see in the adaptability of the supply chain?

18. What kind of problems do you see with adaptability resulting from supply chain complexity?

Research topic 3: Supply chain alignment

Target: Establish incentives for supply chain partners to improve performance of the entire chain (Lee, 2004)

19. What do you associate supply chain adaptability with?

20. How much does supply chain adaptability influence you and your business in the future?

1	2	3	4	5	6	7
---	---	---	---	---	---	---

1 = very significantly, 6 = very little, 7 = no comments

21. What is the expected profit of an increase of supply chain adaptability?

22. What do you think is the expected risk of supply chain adaptability?

23. Which activities does your company realize or intends to realize in order to increase supply chain adaptability?

24. What is necessary/important to create an adaptable supply chain?

25. How do you measure supply chain adaptability?

26. What problems do you see in the adaptability of the supply chain?

27. What kind of problems do you see with adaptability resulting from supply chain complexity?

--

28. Do you think that agility, adaptability and alignment need to be treated equally in terms of prioritization? If yes, why? If no, how and why?









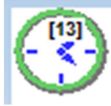
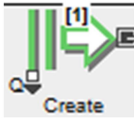
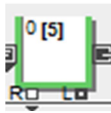
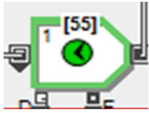

29. Do you think that agility, adaptability and alignment do influence the performance of your firm? To which extent?

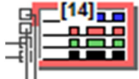
30. Are there other characteristics for an efficient supply chain unless cost-efficiency and speed?

Thank you for your participation! The results will be kept confidential and will only be used for this dissertation, as mentioned in the beginning.

APPENDIX to Chapter 4

Symbols in ExtendSim (Source: ExtendSim9, Userguide, 2013):

Symbol	Description
	Executive block: The block does event scheduling and manages discrete event simulation. It must be presented in every discrete event model.
	Create: Generation of items or values either randomly or on schedule. If used to generate items, it pushes them into the simulation and should be followed by a queue-type block.
	Queue: Acts as a sorted queue or as a resource pool queue. As a sorted queue, holds items in FIFO or LIFO order, or sorts items based on their attribute or priority.
	Activity: Processes one or more items simultaneously. Processing time is a constant or is based on a distribution or an item's attribute.
	Exit: Removes items from the simulation and counts them as they leave.
	Plotter, Discrete Event: Reports the cost development, capacity utilization or other indicators of interest
	Get block: Displays the value of user-assigned and system level item properties: attributes, priorities, quantity, and item index.
	Set block: Attaches user-assigned properties (attribute, priority, and quantity) to items passing
	Select Route: The product and its production location is specified.
	Maths block: Specification and accumulation of costs for evaluation
	Lookup Table: Acts as lookup table. Can be chosen to set it to output data based on the current time or based on the value it receives at its input.
	Random Number: Generates random integers or real numbers based on the selected distribution.
	Holding tank: accumulates the total of the input values. It also allows to request an amount to be removed and outputs that requested amount, if available.

BIBLIOGRAPHY

- Adani, M., Angellara, S., Perona, M., et al., 2002. The integrated management of logistic chains in the white goods industry: A field research in Italy. *International Journal of Production Economics* 69, 227-238.
- Adam, D., Johannville, U., 1998. Die Komplexitätsfalle. *Komplexitätsmanagement*. Wiesbaden, 5-28.
- Aitken, J., Bozarth, C., Garn, W., 2016. To eliminate or absorb supply chain complexity: a conceptual model and case study. *Supply chain Management: An International Journal* 21 (6), 759-774.
- Ansoff, J.I., 1965. *Corporate Strategy: An analytic approach to business policy for growth and expansion*. McGraw-Hill, New York, NY.
- Arminas, D., 2004. Steel yourself for price increases. *Supply Management* 9 (25), 14.
- A.T. Kearney, 2004. The complexity challenge: A survey on complexity management across the supply chain. A.T. Kearney publications. Available at: https://www.atkearney.de/content/misc/wrapper.php/id/49230/name/pdf_complexity_management_s_1096541460ee67.pdf
- Baccarini, D., 1996. The concept of project complexity – a review. *International Journal of Project Management* 14 (4), 201-204.
- Baird, I.S., Thomas, H., 1991. *What is Risk Anyway? Using and Measuring Risk in Strategic Management*. Risk, Strategy and Management 24, Connecticut: Jai Press Inc.
- Baird, I.S., Thomas, H., 1985. Toward a Contingency Model of Strategic Risk Taking. *ACAD Manage Rev* 10 (2), 230-243.
- Baldwin, C.Y., Clark, K.B., 2000. *Design Rules*. MIT Press, Cambridge, p. 471.
- Ballou, R.H., 1992. *Business Logistics Management*. Prentice-Hall Inc., Englewood Cliffs, NJ.
- Banks, J., Buckley, S., Jain, S., Lendermann, P., Manivannan, M., 2002. Panel session: Opportunities for simulation in supply chain management. *Proceedings from the 2002 Winter Simulation Conference*, 1652-1658.
- Barbosa-Povoa, A. P., 2014. Process supply chains management – where are we? Where to go next?. *Process Energy System Engineering*, 2-23.
- Barlas, Y., Carpenter, S., 1990. Philosophical roots of model validation: two paradigms. *System Dynamics Review* 6 (2), 148-166.

- Barney, J.B., 1991. Firm resources and sustained competitive advantage. *Journal of Management* 17 (1), 99-120.
- Barratt, M., 2004. Understanding the meaning of collaboration in the supply chain. *Supply Chain Management: An International Journal* 9 (1), 30-42.
- Barratt, M., Oke, A., 2007. Antecedents of supply chain visibility in retail supply chains: A resource-based theory perspective. *Journal of Operations Management* 25 (6), 1217-1233.
- BCG, 2018. Supply Chain Management. Available at: <https://www.bcg.com/de-de/capabilities/operations/supply-chain-management.aspx>
- Beatham, S., Anumba, C., Thorpe, T., Hedges, I., 2004. KPIs: a critical appraisal of their use in construction. *Benchmarking: An International Journal* 11 (1), 93-117.
- Benton, W.C. and R. Srivastava, 1985. Product Structure Complexity and Multilevel Lot Sizing Using Alternative Costing Policies. *Decision Sciences*, 16 (3), 357-369.
- Berman, S., Korsten, P., 2010. Capitalizing on Complexity, Global Chief Executive Officer Study: 76. IBM Institute for Business Value, Somers, New York.
- Bird, J., 2016. Complex supply chains spell trouble for companies trying to manage risks. *Financial Times*, 25th January 2016.
- Blau, P.M., Shoenherr, R.M., 1971. *The Structure of Organizations*. Basic Books, New York.
- Blecker, T., Abdelkafi, N., 2006. Complexity and variety in mass customization systems: analysis and recommendations. *Management Decision* 44 (7), 908-929.
- Blecker, T., Kaluza, B., Abdelkafi, N., Kreutler, G., 2004. Mass customization vs. Complexity: A Gordian Knot?. *An Enterprise Odyssey: Building Competitive Advantage*. International Conference Proceedings. University of Zagreb. Faculty of Economics and Business.
- Blecker, T., Kersten, W., 2006. *Complexity Management in Supply Chains: Concepts, Tools and Methods*. Erich Schmidt Verlag, 3-67.
- Blecker, T., Kersten, W., Meyer, C., 2005. Development of an approach for analyzing supply chain complexity, in Blecker, T. & Friedrich, G. (Eds.), *Mass Customization Concepts – Tools – Realization*, Gito Verlag, Berlin, 47-59.
- Blome, C., Schoenherr, T., Rexhausen, D., 2013. Antecedents and enablers of supply chain agility and its effect on performance: A dynamic capabilities perspective. *International Journal of Production Research* 51 (4), 1295-1318.

- Blome, C., Schoenherr, T., Eckstein, D., 2014. The impact of knowledge transfer and complexity on supply chain flexibility: A knowledge-based view. *International Journal of Production Economics* 147, 307-316.
- Bode, Ch., Wagner, S., 2015. Structural drivers of upstream supply chain complexity and the frequency of supply chain disruptions. *Journal of Operations Management* 36, 215-228.
- Booth, R., 1996. Agile Manufacturing. *Engineering Management Journal* 6 (2), pp. 105-112.
- Boyer, K.K., and M.L. Swink, 2008. Empirical Elephants – why multiple methods are essential to Quality Research in Operations and Supply Chain Management. *Journal of Operations Management* 26, 337-344.
- Bozarth, C.C., Warsing, D.P., Flynn, B.B., Flynn, E.J., 2009. The impact of supply chain complexity on manufacturing plant performance. *Journal of Operations Management* 27, 78-93.
- Brailsford, S., Hilton, A., 2001. A comparison of discrete event simulation and system dynamics for modeling healthcare systems. *Proceedings of the 26th meeting of the ORAHS Working Group 2000, Glasgow, Scotland*, 18-39.
- Brandon-Jones, E., Squire, B., Autry, C., Petersen, K., 2014. A contingent resource-based perspective of supply chain resilience and robustness. *Journal of Supply Chain Management* 50 (3), 55-73.
- Braunscheidel, M.J., Nallan, C. S., 2009. The organizational antecedents of a firm's supply chain agility for risk mitigation and response. *Journal of Operations Management* 27, 119-140.
- Bromwich, M., Bhimani, A., 1989. *Management accounting: Evolution not revolution*. London: CIMA, UK.
- Calinescu, A., Efstathiou, J., Schirn, J., Bermejo, J., 1998. Applying and assessing two methods for measuring complexity in manufacturing, *Journal of the Operational Research Society* 49, 723-733.
- Calinescu, A., Efstathiou, J., Sivadasan, S., Schirn, J., Huaccho Huatuco, L., 2000. Complexity in Manufacturing: an Information Theoretic Approach. *Proceedings of the International Conference on Complex Systems and Complexity in Manufacturing, Warwick, UK*, 30-44.
- Cao, Z., Lumineau, F., 2015. Revisiting the interplay between contractual and relational governance: A qualitative and meta-analytic investigation. *Journal of Operations Management* 33-34, 15-42.

- Caputo, M., Mininno, V., 1996. Internal, vertical and horizontal logistics integration in Italian grocery distribution. *International Journal of Physical Distribution & Logistics Management* 26 (9), 64-90.
- Charles, A., Lauras, M., Wassenhove, L. V., 2010. A model to define and assess the agility of supply chains: building on humanitarian experience. *International Journal of Physical Distribution & Logistics Management* 40 (8), 722-741.
- Chan, A., Ngai, E., Moon, K., 2017. The effects of strategic and manufacturing flexibilities and supply chain agility on firm performance in the fashion industry. *European Journal of Operational Research* 259, 486-499.
- Chang, Y., Makatsoris, H., 2001. Supply chain modeling using simulation. *International Journal of Simulation* 1.
- Chenhall, R., Langfield-Smith, K., 2007. Multiple perspectives of performance measures. *European Management Journal* 25 (4), 266-282.
- Child, J., 1972. *Organizational structure, environment and performance: the role of strategic choice*. Sage Social Science Collections.
- Childerhouse, P., Towill, D.R., 2003. Simplified material flow holds the key to supply chain integration. *Omega* 31 (1), 17-27.
- Childerhouse, P., Towill, D.R., 2004. Reducing uncertainty in European supply chains. *Journal of Manufacturing Technology Management* 15 (7), 585-598.
- Cho, J., Kang, B., 2001. Benefits and challenges of global sourcing: perceptions of U.S. apparel retail firms. *International Marketing Review* 18 (5), 542-561.
- Choi, T.Y. and Krause, D.R., 2006. The supply base and its complexity: Implications for transaction costs, risks, responsiveness, and innovation. *Journal of Operations Management* 24 (5), 637-652.
- Choi, T.Y., Dooley, K.J., Rungtusanatham, M., 2001. Supply networks and complex adaptive systems: control versus emergence. *Journal of Operations Management* 19 (3), 351-366.
- Chopra, S., Meindl, P., 2012. *Supply chain management: strategy, planning, and operation*. 5th edition Upper Saddle River, NJ, USA. Prentice Hall
- Chopra, S., Sodhi, M.S., 2004. Managing risk to avoid supply-chain breakdown. *MIT Sloan Management Review* 46 (1), 53-61.
- Christopher, M., 2000. The agile supply chain: competing in volatile markets. *Industrial Marketing Management* 29 (1), 37-44.

- Christopher, M., Hau, L., 2001. Supply Chain Confidence: The key to effective Supply Chains through improved visibility and reliability, Stanford.
- Christopher, M., Holweg, M., 2011. "Supply Chain 2.0": Managing supply chains in the era of turbulence. *International Journal of Physical Distribution & Logistics Management* 41 (1), 63-82.
- Christopher, M., Peck, H., 2004. Building the resilient supply chain. *International Journal of Logistics Management* 15 (2), 1-13.
- Christopher, M., Towill, D.R., 2001. An integrated model for the design of agile supply chains. *International Journal of Physical Distribution and Logistics Management* 31 (4), 235-246.
- Closs, D.J., Jacobs, M.A., Swink, M., Webb, G.S., 2008. Toward a theory of competencies for the management of product complexity: Six case studies. *Journal of Operations Management* 26 (5), 590-610.
- Closs, D.J., Nyaga, G. N., Voss, M. D., 2010. The differential impact of product complexity, inventory level and configuration capacity on unit and order fill rate performance. *Journal of Operations Management* 28 (1), 47-57.
- Cox, A., 2004. The art of the possible: relationship management in power regimes and supply chains. *Supply chain Management: An International Journal* (9) 5, 346-356.
- Craighead C., Blackhurst, J., Rungtusanatham, M., Handfield, R., 2007. The severity of supply chain disruptions: design characteristics and mitigation capabilities. *Decision Science* 38 (1), 131-16.
- Croxton, K.L., Garcia-Dastugue, s.J., Lambert, D.M., Rogers, D.S., 2001. The supply chain management processes. *International Journal of Logistics Management* 12, 13-36.
- Cuculelli, M., Ermini, B., 2012. New product introduction and product tenure: what effects on firm growth? *Res. Policy* 41 (5), 808-821.
- Daft, R.L., Lengel, R.H., 1983. Information Richness: a new approach to managerial behavior and organization design. DTIC
- Danese, P., Romano, P., Vinelli, A., 2004. Managing business processes across supply networks: the role of coordination mechanisms. *Journal of Purchasing and Supply Management* 10 (4), 165-177.
- Dencker, J.C, 2006. Relative bargaining power, corporate restructuring, and managerial incentives. *Administrative Science Quarterly* 54 (3), 453-485.

- Desai, P., Kekre, S., Radhakrishnan, S., Srinivasan, K., 2001. Product differentiation and commonality in design: balancing revenue and cost drivers. *Management Science* 41 (1), 37-51.
- Deshmukh, A.V., Talavage, J.J., Barash, M.M., 1992. Characteristics of part mix complexity measure for manufacturing systems. *IEEE International Conference on Systems, Man and Cybernetics, Chicago* (2), 1384-1389.
- Deshmukh, A.V., Talavage, J.J., Barash, M.M., 1998. Complexity in manufacturing systems – Part 1: Analysis of static complexity. *IIE Transactions* 30 (7), 645-655.
- Dooley, K., Ven, A., 1999. Explaining complex organizational dynamics. *Organizational Science* 10 (3), 358-372.
- Doz, Y.L., 1996. The evolution of cooperation in strategic alliances: initial conditions or learning processes? *Strategic Management Journal, Summer Special Issue* 17, 55-83.
- Dubey, R., Singh, T., Gupta O., 2015. Impact of agility, adaptability and alignment on humanitarian logistics performance: mediating effect of leadership. *Global Business Review* 16 (5), 812-831.
- Dubois., A., Hulthen K., Pedersen, A.C., 2004. Supply chains and interdependence: a theoretical analysis. *Journal of Purchasing and Supply Management* 10 (1), 3-9.
- Duclos, L.K., Vokurka, R.J., Lummus R.R., 2003. A conceptual model of supply chain flexibility. *Industrial Management & Data Systems*, 103/6, 446-456.
- Duncan, R.B., 1972. Characteristics of organizational environments and perceived environmental uncertainties. *Administrative Science Quarterly* 17 (3), 313-327.
- Durach, C., Wieland, A., Machuca, J., 2015. Antecedents and dimensions of supply chain robustness: a systematic literature review. *International Journal of Physical Distribution & Logistics Management* 45 (1/2), 118-137.
- Duray, R., Ward, P.T., Milligan, G.W., Berry, W.L., 2000. Approaches to mass customization: configurations and empirical validation. *Journal of Operations Management* 18 (6), 605-625.
- Earl, P., Wakeley, T., 2010. Economic perspectives on the development of complex products for increasingly demanding customers. *Res. Policy* 39 (8), 1122-1132.
- Eckstein, D., Goellner M., Blome, C., Henke, M., 2015. The performance impact of supply chain agility and supply chain adaptability: the moderating effect of product complexity. *International Journal of Production Research* 53 (10), 3028-3046.

- Eglese, R., 2005. A new tabu search heuristic for the open vehicle routing problem. *Journal of the Operational Research Society* 56, 267-274.
- Eisenhardt, K.M., 1989. Building Theories from Case Study Research. *Academy of Management Review* 14 (14), 532-550.
- Eisenhardt, K.M., Graebner, M.E., 2007. Theory building from cases: opportunities and challenges. *Academy of Management Journal* 50 (1), 25-32.
- Ellram, L.M., 1992. Patterns in international logistics. *Journal of Business Logistics* 13 (1), 1-25.
- Ernst, R., Kamrad, B., 2000. Evaluation of supply chain structures through modularization and postponement. *European Journal of Operational Research* 124, 495-510.
- Eskandarpour, M., Dejax, P., Miemczyk, J., Péton, O., 2015. Sustainable supply chain network design: An optimization-oriented review. *Omega* 54, 11-32.
- Ethiraj, S.K., Kale, P., Krishnan M.S., Singh J.V., 2005. Where do capabilities come from and how do they matter? A study in the software services industry. *Strategic Management Journal* 26 (1), 25-45.
- ExtendSim, Imagine That Inc., 2013. User Guide ExtendSim 9. San Jose. Download: 8th July 2015.
- Fandel, G., Stammen, M., 2004. A general model for extended strategic supply chain management with emphasis on product life cycles including development and recycling. *International Journal of Production Economics* 89, 293-308.
- Fawcett, S. E., Magnan G.M., 2002. The rhetoric and reality of supply chain integration. *International Journal of Physical Distribution and Logistics Management* 32 (5), 339-361.
- Fawcett, S. E., Fawcett, A. M., Watson, B. J., Magnan, G.M., 2012. Peking inside the black box: toward an understanding of supply chain collaboration dynamics. *Journal Supply Chain Manage* 48 (1), 44-72.
- Federal Statistical Office, 2012. Economy and Statistics. Available at: [http://www.gesamtmetall.de/gesamtmetall/meonline.nsf/id/Grafiken/\\$FILE/RohstMaterialKosten.pdf](http://www.gesamtmetall.de/gesamtmetall/meonline.nsf/id/Grafiken/$FILE/RohstMaterialKosten.pdf)
- Fisher et al., 1997. Configuring a supply chain to reduce the cost of demand uncertainty. *Production and Operations Management* 73, 318-330.
- Fisher, M., Ramdas, K., Ulrich, K., 1999. Component sharing in the management of product variety: a study of automotive braking systems. *Management Science* 45 (3), 297-315.

- Fisher, R. J., 1993. Social desirability bias and the validity of indirect questioning. *Journal of Consumer Research* 25, 303-314.
- Flood, R. L., Carson, E.R., 1988. *Dealing with Complexity*. Plenum Press, New York.
- Flynn, B.B., Flynn, E.J., 1999. Information processing alternatives for coping with manufacturing environment complexity. *Decision Sciences* 30 (4), 1021-1052.
- Forrester, J.W. (1961). *Industrial Dynamics*. Wiley, New York, NY.
- Fosso Wamba, S., Ngai, E., Riggins, F., Akter, S., 2017. Guest editorial. *International Journal of Operations and Production Management* 37 (1), 2-9.
- Frizelle, G., Woodcock, E., 1995. Measuring complexity as an aid to developing operational strategy. *International Journal of Operations and Production Management* 15 (5), 26-39.
- Galbraith, J., 1973. *Designing Complex Organizations*. Addison-Wesley, Reading, MA.
- Galbraith, J., 1974. Organization design: an information processing view. *Interfaces* 4 (3), 28-36.
- Galbraith, J., 1977. *Organization Design*. Addison-Wesley, Reading, MA.
- Garcia, D. J., You, F., 2015. Supply chain design and optimization: Challenges and opportunities. *Computers and Chemical Engineering* 81, 153-170.
- Gass, S. I., 1983. Decision-Aiding Models: Validation, Assessment, and Related Issues for Policy Analysis. *Operations Research* 31 (4), 603-631.
- Gattorna, J., 2016. *Dynamic supply chain alignment: a new business model for peak performance in enterprise supply chains across all geographies*. CRC Press.
- Ge, H., Gray, R., Nolan, J., 2015. Agricultural supply chain optimization and complexity: A comparison of analytic vs simulated solutions and policies. *International Journal of Production Economics* 159, 208-220.
- Georgiadis, P., Vlachos, D., Iakovou, E., 2005. A system dynamics modeling framework for the strategic supply chain management of food chains. *Journal of Food Engineering* 70, 351-364.
- Ghoshal, S., 1987. *Global Strategy: An Organizing Framework*. *Strategic Management Journal* 8 (5), 425-440.
- Giachetti, R., Martinez, L., Saenz, O., Chen C., 2003. Analysis of the structural measures of flexibility and agility using a measurement theoretical framework. *International Journal of Production Economics* 86 (1), 47-62.

- Gibbert, M., Ruigrok, W., Wicki, B., 2008. Research notes and commentaries: What passes as a rigorous case study?. *Strategic Management Journal* 29, 1465-1474.
- Giunipero, L.C., Eltantawy, R.A., 2004. Securing the upstream supply chain: a risk management approach. *International Journal of Physical Distribution & Logistics Management* 34 (9), 698-713.
- Glaser, B., Strauss, A., 2017. *The Discovery of Grounded Theory: Strategies for qualitative research*. London: Wiedenfeld and Nicholson.
- Glaser, B.G., 1978. *Theoretical Sensitivity*. Mill Valley, CA: The Sociology Press.
- Gligor, D., Holcomb, M., 2012. Understanding the role of logistics capabilities in achieving supply chain agility: A systematic literature review. *Supply Chain Management: An International Journal* 17 (4), 438-453.
- Gligor, D., Holcomb, M., Stank, T., 2013. A multidisciplinary approach to supply chain agility: Conceptualization and scale development. *Journal of Business Logistics* 34 (2), 94-108.
- Gligor, D., Holcomb, M., 2014. The road to supply chain agility: an RBV perspective on the role of logistics capabilities. *International Journal of Logistics Management* 25 (1), 160-179.
- Gordan, W., Graves, S.C., 1995. Principles on the benefits of manufacturing process flexibility. *Management Science* 41 (4), 577-594.
- Goetschalckx, M., Vidal, C.J., Dogan, K., 2002. Modeling and design of global logistics systems: A review of integrated strategic and tactical models and design algorithms. *European Journal of Operational Research* 143 (1), 1-18.
- Grady, M., 1991. Performance measurement: implementing strategy. *Management Accounting* 49-53 (USA).
- Grand View Research, 2015. *Construction Equipment Market Analysis By Product (Earth-Moving Machinery, Material Handling Machinery, Concrete & Road Construction Equipment) and Segment Forecast To 2020*. Available at: <http://www.grandviewresearch.com/industry-analysis/construction-equipment-market-analysis/segmentation>
- Griffin, A., 1993. Metrics for Measuring Product Development Cycle Time. *Journal of Product Innovation Management* 10, 112-1125.
- Griffin, A., 1997. The effect of project and process characteristics on product development cycle time. *Journal of Marketing Research* 34 (1), 24-35.

- Groessler, A., 2010. An exploratory system dynamics model of strategic capabilities in manufacturing. *Journal of Manufacturing Technology Management* 21 (6), 651-669.
- Grogaard, B., 2012. Alignment of strategy and structure in international firms; an empirical examination. *International Business Review* 21 (3), 397-407.
- Guertler, B., Spinler, S., 2015. When does operational risk cause supply chain enterprises to tip? A simulation of intra-organizational dynamics. *Omega*, <http://dx.doi.org/10.1016/j.omega.2015.03.005i>
- Gulati, R., 1999. Network location and learning: the influence of network resources and firm capabilities on alliance formation. *Strategic Management Journal* 20 (5), 397-420.
- Gunasekaran, A., Lai, K., Cheng, T.C.E., 2008. Responsive supply chain: A competitive strategy in a networked economy. *The International Journal of Management Science* 36, 549-564.
- Gunasekaran, A., Ngai, E.W.T., 2004. Virtual supply-chain management. *Production Planning & Control* 15 (6), 584-595.
- Gunasekaran, A., Patel, C., McGaughey R.E., 2004. A framework for supply chain performance measurement. *International Journal of Production Economics* 87, 333-347.
- Gunasekaran, A., Hong, P., Fujimoto, T., 2014. Building supply chain system capabilities in the age of global complexity: Emerging theories and practices. *International Journal of Production Economics* 147, 189-197.
- Gunasekaran, A., Subramanian, N., Rahman, S., 2015. Supply chain resilience: role of complexities and strategies. *International Journal of Production Research* 53 (22), 6809-6819.
- Gunasekaran, A., Papadopoulos, T., Dubey, R., Wamba, S., Childe, S., Hazen, B., Akter, S., 2017. Big data and predictive analytics for supply chain and organizational performance. *Journal of Business Research* 70, 308-317.
- Gupta, S., Krishnan, V., 1999. Integrated component and supplier selection for a product family. *Production and Operations Management* 8 (2), 163-182.
- Hagel, J., 1988. Managing complexity. *McKinsey Quarterly*, Spring, 2-23.
- Handfield, R.B., Melnyk, S.A., 1998. The Scientific Theory-Building Process: A Primer Using the Case of TQM. *Journal of Operations Management* 16, 321-339.

- Hauser, S., Shmilovici A., Alon-Brimer, Y., 2003. Using a Stochastic Complexity Measure to Check the Efficient Market Hypothesis. *Computational Economics* 22, 273-284.
- Hayes, R.H., Wheelwright, s.C., 1979. Link manufacturing and product life cycles. *Harvard Business Review* 57 (1), 133-140.
- Heim, G., Peng, D., Jayanthi, A., 2014. Longitudinal analysis of inhibitors of manufacturer delivery performance. *Decision Sciences* 45 (6), 1117-1158.
- Hill, T., 1994. *Manufacturing Strategy: Text and Cases*, second ed. Irwin, Blue Ridge, IL.
- Hillier, M.S., 2000. Component commonality in multiple-period, assemble-to-order systems. *IIE Transactions* 32 (8), 755.
- Holweg, M., Pil, F. K., 2008. Theoretical perspectives on the coordination of supply chains. *Journal of Operations Management* 26 (3), 389-406.
- Hoole, R., 2006. Drive complexity out of your supply chain. *Harvard Business School Newsletter* (January), 3-5. Available at: <http://www.gtai.de/GTAI/Content/EN/Invest/SharedDocs/Downloads/GTAI/Industry-overviews/industry-overview-machinery-equipment.pdf>
- Hoque, Z., 2014. 20 years of studies on the balanced scorecard: trends, accomplishments, gaps and opportunities for future research. *The British accounting review* 46 (1), 33-59.
- Hu, S.J., Zhu, X., Wang, H., Koren, Y., 2008. Product variety and manufacturing complexity in assembly systems and supply chain. *CIRP Annals – Manufacturing Technology* 57 (1), 45-48.
- Huckman, R.S., Staats, B.R., Upton D.M., 2009. Team familiarity, role experience, and performance: evidence from Indian software services. *Management Science* 55 (1), 85-100.
- Huebner, A., Kuhn, H., Wollenburg, J., 2016. Last mile fulfilment and distribution in omni-channel grocery retailing: a strategic planning framework. *International Journal of Retail & Distribution Management* 44 (3), 228-247.
- Hunt, S.D., Davis, D.F., 2012. Grounding supply chain management in resource-advantage theory: in defense of a resource-based view of the firm. *Journal of Supply Chain Management* 48 (2), 14-20.
- IHS, 2014. Rise of the Machines: Industrial Machinery Market Growth to Double in 2014. <http://press.ihs.com/press-release/design-supply-chain/rise-machines-industrial-machinery-market-growth-double-2014>

- Isik, F., 2011. Complexity in supply chains. A new approach to quantitative measurement of the supply chain complexity. *Supply Chain Management*, 184-188.
- Ismail, H.S., Sharifi, H., 2006. A balanced approach to building agile supply chains. *International Journal of Physical Distribution & Logistics Management* 36 (6), 431-444.
- Ivanov, D., Sokolov, B., Kaeschel, J., 2010. A multi-structural framework for adaptive supply chain planning and operations control with structure dynamics considerations. *European Journal of Operations Research* 200, 409-420.
- Iwata, K., Onosato, M., 1994. Random manufacturing system: a new concept of manufacturing systems for production to order. *Proceedings of the CIRP*, 379-384.
- Jacobs, M., 2013. Complexity: Towards an empirical measure. *Technovation* 33 (4-5), 111-118.
- Jacobs, B., Levy, K., Markowitz, H., 2004. Financial Market Simulation. *The Journal of Portfolio Management*. 30th Anniversary Issue, 142-151.
- Jacobs, M., Swink, M., 2011. Product portfolio architectural complexity and operational performance: Incorporating the roles of learning and fixed assets. *Journal of Operations Management* 29, 677-691.
- Jain, S., Workman, R.W., Collins, L.M., Ervin, E.C., 2001. Development of a high-level supply chain simulation model. *Proceedings of the 2001 Winter Simulation Conference*, 1129-1137.
- Jansen, D.R., van Weert, A., Beulens, A. J.M., Huire, R.B.M., 2001. Simulation model of multi-compartment distribution in the catering supply chain. *European Journal of Operational Research* 133, 210-224.
- Johnson, P., 2003. The Challenge of Complexity in Global Manufacturing. *Critical Trends in Supply Chain Management*. *Supply Chain Practice* 5 (3), 54-67.
- Juettner, U., Peck, H., Christopher, M., 2003. Supply chain risk management: Outlining an agenda for future research. *International Journal of Logistics: Research & Applications* 6 (4), 197-210.
- Juettner, U., 2005. Supply chain risk management: Understanding the business requirements from a practitioner perspective. *The International Journal of Logistics Management* 16 (1), 120-141.

- Jun, J.B., Jacobsen, S.H., Swisher, J.R., 1999. Application of discrete-event simulation in health care clinics: A survey. *Journal of the Operational Research Society* 50, 109-123.
- Kaluza, B., Bliem, H., Winkler, H., 2006. Strategies and Metrics for Complexity Management in Supply Chains, in Blecker, T. & Kersten, W. (Eds.), *Complexity Management in Supply Chains: Concepts, Tools and methods*, Erich Schmidt Verlag, Berlin, 3-19.
- Kaplan, R., Norton, D., 1992. The balanced scorecard – measures that drive performance. *Harvard Business Review* 70 (1), 71-79.
- Kaplan, R., Norton, D., 2001. Transforming the Balanced Scorecard from Performance Measurement to Strategic Management: Part I. *Accounting Horizons* 15 (1), 87-104.
- Kauffman, S., 1993. *The origins of order*. Oxford University Press, New York.
- Kaynak, H., 2005. Implementing JIT Purchasing: Does the level of technical complexity in the production process make a difference. *Journal of Managerial Issues* 17 (1), 76-100.
- Kekre, S., Srinivasan K., 1990. Broader product line: a necessity to achieve success? *Management Science* 36 (10), 1216-1231.
- Kembro, J., Selviaridis, K., 2015. Exploring information sharing in the extended supply chain: an interdependence perspective. *Supply Chain Management: An International Journal* 20 (4), 455-470.
- Kembro, J., Selviaridis, K., Näslund, D., 2014. Theoretical perspectives on information sharing in supply chains: a systematic literature review and conceptual framework. *Supply Chain Management: An International Journal* 19 (5/6), 609-625.
- Kersten, W., Rall, K., Meyer, C. M., Dalhöfer, J., 2006. *Complexity Management in Supply Chains: Concepts, Tools and Methods*, Erich Schmist Verlag, Berlin, 325-342.
- Kestel, R., 1995, *Ganzheitliches Komplexitätsmanagement*. Wiesbaden: Gabler Verlag.
- Ketchen, D.J., Hult, G.T., 2007. Bridging organization theory and supply chain management: The case of best value supply chains. *Journal of Operations Management* 25, 573-580.
- Khanna, V. K., Vat, P., Shankar, R., Sahay, B.S. & Gautam, A., 2003. TQM modeling of the automobile manufacturing sector: a system dynamics approach. *Work Study*, 52 (2), 94-101.

- Kirchhoff, R., 2003. Ganzheitliches Komplexitätsmanagement. Wiesbaden: Gabler Verlag.
- Kleindorfer, P.R., Saad, G.H., 2005. Managing disruption risks in supply chains. *Production and Operations Management* 14 (1), 53-68.
- Klir, G., 1985. *Systems Research and Behavioral Science* 2 (2), 131-140.
- Kogut, B., 1985. Designing Global Strategies: Profiting from Operational Flexibility. *Sloan Management Review* 27 (1), 27-38.
- Kogut, B., Kulatilaka, N., 2001. Capabilities as Real Options. *Inform Organization Science* 12 (6), 744-758.
- Kotteaku, A.G., Laios L. G., and Moschuris, S.J., 1995. The Influence of Product Complexity on the Purchasing Structure. *Omega* 23 (1), 27-39.
- Kotz, J., Treichel, P.J., 1996. *Chemistry and Chemical Reactivity*. 3rd ed. Saunders, Toronto, 952.
- Koudal, P., Engel, D. A., 2007. Globalization and emerging markets the challenge of continuous global network optimization. *Building Supply Chain Excellence in Emerging Economies* 98, 37-66.
- KPMG, 2011, Supply Chain Complexity: Managing constant change. Available at: <https://www.kpmg.com/US/en/IssuesAndInsights/ArticlesPublications/Documents/supply-chain-complexity-managing-constant-change.pdf>
- Krahl, D., 2007. ExtendSim 7. Proceedings of the 39th conference on Winter simulation: 40 years! (Dec. 09-12). S.G. Henderson, B. Biller, M.-H. Hsieh, J. Shortle, J.D. Tew, and R.R. Barton (Eds.). Washington D.C. pp. 226-232.
- Krishnan, V., Gupta, S., 2001. Appropriateness and impact of platform-based product development. *Management Science* 47 (1), 52-68.
- Lambert, D.M., Cooper, M.D., 2000. Issues in Supply Chain Management. *Industrial Marketing Management* 29, 65-83.
- Lambert, D.M., Emmelhainz, M., Gardner, J., 1996. Developing and Implementing Supply Chain Partnerships. *International Journal of Logistics Management* 7 (2), 1-17.
- Lambert, D. M., Pohlen, T. L., 2001. Supply Chain Metrics. *International Journal of Logistics Management* 12 (1), 1-19.
- Lane, D.C., 1997. Invited Review and Reappraisal: Industrial Dynamics. *Journal of the Operational Research Society* 48, 1037-1042.

- Law, A.M., 2007. Simulation modeling and analysis. 4th ed. Boston, London. McGraw-Hill.
- Lee, H., Whang, S., 1999. Decentralized multi-echelon supply chains: incentives and information. *Management Science* 45 (5), 633-640.
- Lee, H. L., 2004. The Triple-A Supply Chain. *Harvard Business Review* 82 (10), 102-112.
- Lee, H.L, Padmanabhan, V., Whang, S., 1997. The bullwhip effect in supply chains. *Sloan Management Review* 38 (3), 93-102.
- Lee, Y.H., Cho, M.K., Kim, S.J., Kim, Y.B., 2002. Supply chain simulation with discrete-continuous combined modeling. *Computers & Industrial Engineering* 43, 375-392.
- Li, X., Chung, C., Goldsby, T., Holsapple, C., 2008. A unified model of supply chain agility: the work-design perspective. *International Journal of Logistics Management* 19 (3), 408-435.
- Li, X., Goldsby, T., Holsapple, C., 2009. Supply chain agility: scale development. *The International Journal of Logistics Management* 20 (3), 408-424.
- Lessard, D.R., Lightstone, J.B., 1986. Volatile Exchange Rates Can Put Operations at Risk. *Harvard Business Review* 64 (4), 107-114.
- Lewis, M.W., 1998. Iterative triangulation: a theory development process using existing case studies, *Journal of Operations Management* 16, 455-69.
- Liao, Y., Hont, P., Rao, S. S., 2010. Supply management, supply flexibility and performance outcomes: an empirical investigation of manufacturing firms. *Journal of Supply Chain Management* 46 (3), 6-22.
- Malina, S., Spinler, S., 2013. Management of Supply Chain Complexity: A Study in the Drive and Control Industry. Presented at EURO-INFORMS Conference, Rome/Italy, July 01-04, 2013.
- Malina, S., Spinler, S., 2018. Supply Chain Agility: A Case Study in the Drive and Control Industry. Unpublished manuscript.
- Malina, S., Spinler, S., 2018. Reduction of SCC by Redesigning the Supply Chain: A Discrete-Event Simulation in the Machine Construction Industry. Unpublished manuscript.
- Manivannan, M.S., 1998. Simulation of logistics and transportation systems. In: Banks, J. (Ed.), *Handbook of Simulation*. Wiley, New York, 571-604.

- Manuj, I., Mentzer, J.T., 2008. Global Supply Chain Risk Management Strategies. *International Journal of Physical Distribution & Logistics Management* 38 (3), 192-223.
- Manuj, I., Sahin, F., 2011. A model of supply chain and supply chain decision-making complexity. *International Journal of Physical Distribution & Logistics Management* 41 (5); 511-549.
- Marginson, D.E.W., 2002. Management control systems and their effects on strategy formation at middle-management levels: evidence from a U.K. organization. *Strategic Management Journal* 23 (11), 1019-1031.
- Mariotti, J.L., 2008. *The complexity crisis*. Massachusetts: Platinum Press.
- Mason, R.B., 2007. The external environment's effect on management and strategy: a complexity theory approach. *Management Decision* 45 (1), 10-28.
- Matthews, R., MacCarthy, B., Braziotis, C., 2017. Organisational learning in SMEs: a process improvement perspective. *International Journal of Operations & Production Management* 37 (7), 970-1006.
- Mazzocchi, F., 2008. Complexity in biology. Exceeding the limits of reductionism and determinism using complexity theory. *EMBO Reports* 9 (1), 10-14.
- McCutcheon, D.M., Meredith, J.R., 1993. Conducting case study research in operations management. *Journal of Operations Management* 16 (4), 441-454.
- McDermott, C.M., Stock, G.N., 1999. Organizational culture and advanced manufacturing technology implementation. *Journal of Operations Management* 17 (5), 521-532.
- McKinsey, 2017. Cost comparison of a carbon, aluminium and steel component in 2010 and the forecast for 2030. Statista 2017. Available at: <https://de.statista.com/statistik/daten/studie/221687/umfrage/vergleich-der-kosten-von-carbon-aluminum-und-stahl/>
- McLachlin, R., 1997. Management initiatives and just-in-time manufacturing. *Journal of Operations Management* 15, 271-292.
- McNair, C., Lynch, R., Cross, K., 1990. Do financial and nonfinancial performance measures have to agree? *Management Accounting* 28-36 (USA).
- Meade, L., Sarkis, J., 2002. A conceptual model for selecting and evaluating third-party reverse logistics providers. *Supply Chain Management: An International Journal* 7 (5), 283-295.
- Meeker, B., Parikh, D., Jhaveri, M., 2009. The complexity conundrum. *Marketing Management* 18 (1), 54-59.

- Mentzer, J.T., DeWitt, W., Keebler, J.S., Min, S., Nix, N.W., Smith, C.D., Zacharia, Z.G., 2001. Defining supply chain management 22 (2), 1-25.
- Meredith, J., 1998. Building Operations Management Theory Through Case and Field Research. *Journal of Operations Management* 16 (4), 439-454.
- Meyer, M.H., Lehnerd, A.P., 1997. *The Power of Product Platforms*. Free Press, NY.
- Meyer, M.H., Mugge, P.C., 2001. Make platform innovation drive enterprise growth. *Research-Technology Management* 44 (1), 25-39.
- Mihalīs, G., Michalīs L., 2016. A multi-agent based system with big data processing for enhanced supply chain agility. *Journal of Enterprise Information Management* 29 (5), 706-727.
- Milgate, M., 2001. Supply chain complexity and delivery performance: an international exploratory study. *Supply Chain Management: An International Journal* 6 (3), 106-118.
- Miller, K.D., 1992. A Framework for Integrated Risk Management in International Business. *Journal of International Business Studies* 23 (2), 311-331.
- Miragliotta, G., Perona, M., 2002. Complexity management in the supply chain: Theoretical model and empirical investigation in the Italian appliance industry. *Cost management in Supply Chains*. *Physica HD*, 381-397.
- Morecroft, J.D.W., Robinson, S., 2005. Explaining Puzzling Dynamics: Comparing the use of System Dynamics and discrete-event simulation. In *Proceedings of the 23rd International Conference of the System Dynamics Society*, Boston.
- Nahm, A.Y., Vonderembse, M.A., Koufteros, X.A., 2004. The impact of organizational culture on time-based manufacturing and performance. *Decision Sciences*, 35 (4), 579-607.
- Narasimhan, R., Swink M., Kim, S.W., 2006. Disentangling leanness and agility: an empirical investigation. *Journal of Operations Management* 24, 440-447.
- Narasimhan, R., Talluri, S., 2009. Perspectives on risk management in supply chains. *Journal of Operations Management* 27 (2), 114-118.
- Norrman, A., Jansson, U., 2004. Ericsson's proactive supply chain risk management approach after a serious sub-supplier accident. *International Journal of Physical Distribution & Logistics Management* 34 (5), 434-456.
- Novak, S., Eppinger, S., 2001. Sourcing by Design: Product complexity and the supply chain. *Management Science* 47 (1), January 2001.

- OECD, 2009. Responding to the economic crisis: Fostering industrial restructuring and renewal. Available at: <http://www.grandviewresearch.com/industry-analysis/construction-equipment-market-analysis/segmentation>
- Okino, N., 1993. Bionic manufacturing systems. Flexible Manufacturing Systems, Past, Present, Future; Faculty of Mechanical Engineering, Ljubljana, 73-95.
- Oliva, R., 2004. Model structure analysis through graph theory: partition heuristics and feedback structure decomposition. System Dynamics Review 20 (4), 313-336.
- Oreskes, N., Shrader-Frechette, K., Belitz, K. & others, 1994. Verification, validation, and confirmation of numerical models in the earth sciences. Science, 263 (5147), 641-646.
- Ottino, J.M., 2011. Chemical engineering in a complex world: grand challenges, vast opportunities. Chemical Engineering Journal 57 (7), 1654-1668.
- Papageorgiou, L. G., 2009. Supply chain optimization for the process industries: advances and opportunities. Computer Chemical Engineering 33 (12), 1931-1938.
- Park, Y., Hong, P., Roh, J., 2013. Supply chain lessons from the 2011 natural disasters in Japan. Business Horizon. 56 (1), 75-85.
- Park, Y., Hong, P., 2012. Building network capabilities in turbulent competitive environments: Practices of global firms from Korea and Japan. CRC Press: Taylor & Francis Company, Boca Raton, USA.
- Parmenter, D., 2015. Key performance indicators: developing, implementing, and using winning KPIs. John Wiley & Sons.
- Payne, J.W., 1975. Task complexity and contingent processing in decision making: an information search and protocol analysis. Organizational Behaviour and Human Performance 16, 366-387.
- Penrose, E.T., 1959. The theory of the growth of the firm. Wiley, New York, NY.
- Perona, M., Miragliotta, G., 2004. Complexity management and supply chain performance assessment: A field study and a conceptual framework. International Journal of Production Economics 90 (1), 103-115.
- Persson, F., Araldi, M., 2009. The development of a dynamic supply chain analysis tool – Integration of SCOR and discrete event simulation. International Journal Production Economics 121, 574-583.
- Pfeffer, J., 1981. Power in Organizations. Pittman, Marshfield, MA.

- Pfeffer, J., Salancik, G.R., 1978. *The External control of Organizations: A Resource Dependence Perspective*, Harper & Row, New York, NY.
- Pfohl, H. C., Buse, H. P., 2000. Inter-organizational logistics systems in flexible production networks: An organizational capabilities perspective. *International Journal of Physical Distribution & Logistics Management* 30 (5), 388-408.
- Pidd, M., 2004. *Computer Simulation in Management Science*. 5th edition ed. Chichester. John Wiley & Sons.
- Pierreval, H., Bruniaux, R., Caux, C., 2007. A continuous simulation approach for supply chains in the automotive industry. *Simulation Modelling Practice and Theory* 15, 185-198.
- Ponomarov, S., Holcomb, M., 2009. Understanding the concept of supply chain resilience. *International Journal of Logistics Management* 20 (1), 124-143.
- Porter, M.E., 1980. *Competitive Strategy*. The Free Press, New York, N.Y.
- Porter, M.E., 1985. *Competitive Advantage*. The Free Press, New York, NY.
- Postma, T.J.B.M., Liebl, F., 2005. How to improve scenario analysis as a strategic management tool? *Technological Forecasting & Social Change* 72, 161-173.
- Prahalad, C.K., Hamel, G., 1990. The core competence of the corporation. *Harvard Business Review* 68 (3), 79-91.
- Prater, E., Biehl, M., Smith, M.A., 2001. International supply chain agility – Tradeoffs between flexibility and uncertainty. *International Journal of Operations & Production Management* 21 (5/6), 823-839.
- Price, J.L., Mueller, C.W., 1986. *Complexity: Handbook of Organizational Measurement*. Pitman Publishing, Marshfield, MA.
- Priem, R.L., Swink, M., 2012. A demand-side perspective on supply chain management. *Journal of Supply Chain Management* 48 (2), 7-13.
- Qudrat-Ullah, H. & Seong, B.S., 2010. How to do structural validity of a system dynamics type simulation model: the case of an energy policy model. *Energy Policy* 38 (5), 2216-2224.
- Quelch, J.A., Kenny, D., 1994. Extend profits, not product lines. *Harvard Business Review* 72 (5), 153-160.
- Ramdas, K., Sawhney, M.S., 2001. A cross-functional approach to evaluating multiple line extensions for assembled products. *Management Science* 47 (1), 22-36.

- Raue, J.S., Wallenburg, C. M., 2013. Alike or not? Partner similarity and its outcome in horizontal cooperations between logistics service providers. *Logistics Research* 6 (4), 217-230.
- Ready, P.J., Gunasekaran, A., Spalanzani, A., 2015. Bottom-up approach based on internet of things for order fulfilment in a collaborative warehousing environment. *International Journal of Production Economics* 159, 29-40.
- Reuter, C., Foerstl, K., Hartmann, E., Blome C., 2010. Sustainable global supplier management: the role of dynamic capabilities in achieving competitive advantage. *Journal of Supply Chain Management* 46 (2), 45-63.
- Robertson, C., Diyab, A., Al-Kahtani, A., 2013. A cross-national analysis of perceptions of corporate governance principles. *International Business Review* 22 (1), 315-325.
- Robertson, D., Ulrich, K., 1998. Planning for Product Platforms. *MIT Sloan Management Review* 39 (4), 19-31.
- Robinson, S. 2004. *Simulation: The Practice of Model Development and Use*. Chichester, John Wiley & Sons.
- Roh, J., Hong, P., Min, H., 2014. Implementation of a responsive supply chain strategy in global complexity: The case of manufacturing firms. *International Journal of Production Economics* 147, 198-210.
- Rumelt, R., 1984. Towards a strategic theory of the firm. *Competitive Strategic Management*. Prentice-Hall, Englewood Cliffs, NJ, 556-570.
- Rushton, A., Oxley, J., 1989. *Handbook of Logistics and Distribution Management*. Kogan Page Ltd., London.
- Rutenberg, D., Shaftel, T.L., 1971. Design commonality to reduce multi-item inventory: optimal depth of a product line. *Operations Research* 19 (2), 491-509.
- Safizadeh, M.H., Ritzman, L.P., Sharma, D., Wood, C., 1996. An empirical analysis of the product-process matrix. *Management Science* 42 (11), 1576-1591.
- Salvador, F., Forza, C., Rungtusanatham, C.M., 2002. Modularity, product variety, production volume, and component sourcing: theorizing beyond generic prescriptions. *Journal of Operations Management* 20 (5), 549-575.
- Sargent, R., 2013. Verification and validation of simulation models. *Journal of Simulation* 7, 12-24.
- Schoenherr, T., Hilpert, D., Soni, A., Venkataramanan, M., Mabert, V., 2010. Enterprise systems complexity and its antecedents: a grounded-theory approach. *International Journal of Operations & Productions Management* 30 (6), 639-668.

- Scholz-Reiter, B., Windt, K., Freitag, M., 2004. Autonomous logistic processes: new demands and first approaches, in Monostori, L. (Ed.), Proceedings of the 37th CIRP International Seminar on Manufacturing Systems, Budapest, 736-762.
- Schriber, T.J., Brunner, D.T., Smith, J.S., 2014. Inside discrete-event simulation software: How it works and why it matters. Proceedings of the 2014 Winter Simulation Conference, 132-146.
- Schwandt, T.A., 1997. Qualitative inquiry: a dictionary of terms. Thousand Oaks, CA: Sage.
- Scott, W.R., 1992. Institutional Environments and Organizations: Structural complexity and Individualism. London/Thousand Oaks, CA: Sage.
- Serdarasan, S., 2013. A review of supply chain complexity drivers. Computers & Industrial Engineering 66, 533-540.
- Sethi, A., Sethi, S., 1990. Flexibility in manufacturing: A survey. International Journal of Flexible Manufacturing Systems 2, 289-328.
- Seuring, S., 2004. Industrial ecology, life cycles, supply chains: differences and interrelations. Business strategy and the Environment 13 (5), 306.
- Seuring et al., 2004. Managing time and complexity in supply chains, Two cases from the textile industry. International Journal of Integrated Supply Management 1 (2), 180-198.
- Shafiee, M., Lotfi, F., Saleh, H., 2014. Supply chain performance evaluation with data envelopment analysis and balanced scorecard approach. Applied Mathematical Modelling 38 (21-22), 5092-5112.
- Shapiro, J.F., 2001. Modelling the Supply Chain. Duxbury, Pacific Grove.
- Sharif, A., Irani, Z., 2012. Supply chain leadership. International Journal of Production Economics 140 (1), 57-68.
- Sharp, J.M., Irani, Z., Desai, S., 1999. Working towards agile manufacturing in the UK industry. International Journal of Production Economics 62 (1/2), 155-169.
- Simon, H.A., 1962. The architecture of complexity. Proceedings of the American Philosophical Society 106 (6), 467-482.
- Sinclair, G., Klepper, S., Cohen, W., 2000. What's experience got to do with it? Sources of cost reduction in a large specialty chemicals producer. Management Science 46 (1), 28-45.
- Singh, K., 1997. The impact of technological complexity and interfirm cooperation on business survival. Academy of Management Journal 40 (2), 339-367.

- Sivadasan, S., Efstathiou, J., Calinescu, A., Huaccho Huatuco, L., 2002b. Policies for managing operational complexity in the supply chain. Proceedings of Manufacturing Complexity Network Conference, 9-10 April 2002, Cambridge, UK, 549-555.
- Sivadasan, S., Efstathiou, J., Calinescu, A., Huaccho Huatuco, L., 2004. Supply chain complexity, in New, S. & Westbrook, R. (Eds.), *Understanding Supply Chains: Concepts, Critiques and Futures*, Oxford University Press, UK, 133-163.
- Sivadasan, S., Efstathiou, J., Calinescu, A., Huaccho Huatuco, L., 2002b. Policies for managing operational complexity in the supply chain. Proceedings of Manufacturing Complexity Network Conference, 9-10 April 2002, Cambridge, UK, 549-555.
- Sivadasan, S., Efstathiou, J., Calinescu, A., Huaccho Huatuco, L., 2004. Supply chain complexity, in New, S. & Westbrook, R. (Eds.), *Understanding Supply Chains: Concepts, Critiques and Futures*, Oxford University Press, UK, 133-163.
- Sivadasan, S., Efstathiou, J., Shirazi, R., Calinescu, A., 2002a. An information-theoretic methodology for measuring the operational complexity of supplier-customer systems. *International Journal of Operations and Production Management* 22 (1), 80-102.
- Sivadasan, S., Efstathiou, J., Shirazi, Rl, Alves, J., Frizelle, G., Calinescu, A., 1999. Information complexity as a determining factor in the evolution of supply chains. Proceedings of the International Workshop on Emergent Synthesis, Kobe, Japan, 237-242.
- Skipper, J., Craighead, C., 2008. Towards a theoretical foundation of supply network interdependence and technology-enabled coordination strategies. *International Journal of Physical Distribution & Logistics Management* 38 (1), 39-56.
- Soosay, C.A., Hyland, P.W., Ferrer, M., 2008. Supply chain collaboration: capabilities for continuous innovation. *Supply Chain Management: An International Journal* 13 (2), 160-169.
- Spekman, R.E., Davis, E.W., 2004. Risky business: expanding the discussion on risk and the extended enterprise. *International Journal of Physical Distribution & Logistics Management* 34 (5), 414-433.
- St. George, A., 1998. Li and Fung: Beyond 'Filling in the Mosaic.' Harvard Business School Case 9-398-092.
- Sterman, J.D., 2000. *Business Dynamics: Systems Thinking and Modeling for a Complex World*. London, McGraw-Hill.

- Stevens, G.C., 1989. Integrating the Supply Chain. *International Journal of Physical Distribution & Materials Management* 19 (8), 3-8.
- Stevenson, M., Spring, M., 2007. Flexibility from a supply chain perspective: definition and review. *International Journal of Operations & Production Management* 27 (7), 685-713.
- Stevenson, M., Spring, M., 2009. Supply chain flexibility: an inter-firm empirical study. *International Journal of Operations & Production Management* 29 (9), 946-971.
- Stuart, I., McCutcheon, D., Handfield R., McLachlin, R., Samson, D., 2002. Effective Case Research in Operations Management: A Process Perspective. *Journal of Operations Management* 20 (5), 419-433.
- Subramanian, N., Rahman, S., 2014. Supply chain complexity and strategy. *Supply chain strategies, Issues and Models*, Springer-Verlag, London.
- Sun, C., Rose, T., 2015. Supply chain complexity in the semiconductor industry: Assessment from system view and the impact of changes. *IFAC-PapersOnLine* 48 (3), 1210-1215.
- Surana, A., Kumara, S., Greaves, M., Raghavan, U.N., 2005. Supply-chain networks: a complex adaptive systems perspective. *International Journal of Production Research* 43 (20), 4235-4265.
- Swafford, P.M., Ghosh, S., Murthy, N., 2006. The antecedents of supply chain agility of a firm: scale development and model testing. *Journal of Operations Management* 24 (2), 170-188.
- Swart, R.J., Raskin, P., Robinson, J., 2004. The problem of the future: sustainability science and scenario analysis. *Global Environment Change* 14, 137-146.
- Sweetser, A., 1999. A comparison of system dynamics and discrete event simulation. In *Proceedings of 17th International Conference of the System Dynamics Society and 5th Australian & New Zealand Systems Conference*, Wellington, New Zealand.
- Swink, M., 2006. Building collaborative innovation capability. *Research Technology Management* 49 (2), 37-48.
- Sun, C., Thomas, R., 2015. Supply chain complexity in the semiconductor industry: Assessment from System View and the Impact of Changes. *IFAC-PapersOnLine* 48-3, Science Direct, 2010-2015.
- Tako, A.A., Robinson, S., 2009. Comparing discrete event simulation and system dynamics: User's perceptions. *Journal of the Operational Research Society* 60, 296-312.

- Tako, A.A., Robinson, S., 2010. Model development in discrete event simulation and system dynamics: an empirical review. *European Journal of Operational Research* 207, 784-794.
- Tako, A.A., Robinson, S., 2012. The application of discrete event simulation and system dynamics in the logistics and supply chain context. *Decision Support Systems*, 52(4), 802-815.
- Tan, K.C., Kannan, V.R., Handfield, R.B., Ghosh, S., 1999. Supply chain management: an empirical study of its impact on performance. *International Journal of Operations & Production Management* 19 (10), 1034-1052.
- Tang, L., Jing, K., He, J., Stanley, H., 2016. Complex interdependent supply chain networks: Cascading failure and robustness. *Physica A: Statistical Mechanics and its Applications* 443, 58-69.
- Tatikonda, M.V., Stock, G.N., 2003. Product Technology Transfer in the Upstream Supply Chain. *The Journal of Product Innovation Management* 20, 444-467.
- Teece, D.J., Pisano, G.P., Shuen, A., 1997. Dynamic capabilities and strategic management. *Strategic Management Journal* 18 (7), 509-533.
- Tharumarajah, a., Wells, A., Nemes, L., 1996. Comparison of the bionic, fractal and holonic manufacturing system concepts. *International Journal of Computer Integrated Manufacturing* 9 (3), 217-226.
- Thompson, J. D., 1967. *Organizations in Action*. McGraw-Hill, New York, NY.
- Thonemann, U.W., Bradley, J.R., 2002. The effect of product variety on supply chain performance. *European Journal of Operational Research* 143 (3), 548-569.
- Towill, D.R., 1996b. Time compression and supply chain management – a guided tour. *Supply chain management* 1 (1), 15-27.
- Towill, D.R., Naim, M., 1993. Supply chain: Partnership sourcing smooths supply chain dynamics. *Purchasing & Supply Management*, July/August, 38-42.
- Turner, K., Williams, G., 2005. Modelling complexity in the automotive industry supply chain. *Journal of Manufacturing Technology Management* 16 (4), 447-458.
- Ueda, K., 1993. A genetic approach toward future manufacturing systems, in Peklenik, J. (Ed.), *Flexible Manufacturing Systems, Past, Present, Future*, Faculty of Mechanical Engineering, Ljubljana, 221-228.
- Vachon, S., Klassen, R., 2002. An exploratory investigation of the effects of supply chain complexity on delivery performance. *IEEE Transactions on Engineering Management* 49, (3), 218-230.

- Vahlne, J., Ivarsson, I., Johanson, J., 2011. The tortuous road to globalization for Volvo's heavy truck business: extending the scope of the Uppsala model. *International Business Review* 20 (1), 1-14.
- Van der Vorst, J. G., Beulens, A. J., 2002. Identifying sources of uncertainty to generate supply chain redesign strategies. *International Journal of Physical Distribution & Logistics Management* 32 (6), 409-430.
- VDMA, 2012. Industry Overview The machinery & equipment industry in Germany. Issue 2013/2014. Germany Trade and Invest. Accessed: 16th July 2013.
- Vorst van der, J., Beulens, A., 2002. Identifying sources of uncertainty to generate supply chain redesign strategies. *International Journal of Physical Distribution & Logistics Management* 32 (6), 409-430.
- Voss, C., Tsikrikitis, N., Frohlich, M., 2002. Case research in operations management. *International Journal of Operations & Production Management* 22 (2), 195-219.
- Wacker, J.G., 1998. A definition of theory: research guidelines for different theory-building research methods in operations management. *Journal of Operations Management* 16, 361-385.
- Wacker, J., Yang, C., Sheu, C., 2016. A transaction cost economics model for estimating performance effectiveness of relational and contractual governance. *International Journal of Operations & Production Management* 36 (11), 1551-1575.
- Ward, C., 1994. What is Agility. *Industrial Engineering*. 14-16.
- Warnecke, H., 1993. *The Fractal Company: A Revolution in Corporate Culture*. Springer, Berlin.
- Wassick, J. M., 2009. Enterprise-wide optimization in an integrated chemical complex. *Computer Chemical Engineering* 33 (12), 1950-1963.
- Weber, J., 2012. *Logistik-Controlling mit Kennzahlensystemen*. WHU – Otto Beisheim School of Management Vallendar.
- Webster, F.E., 1992. The changing role of marketing in the corporation. *Journal of Marketing* 56 (4), 1-17.
- Wernerfeldt, B., 1984. A resource-based view of the firm. *Strategic Management Journal* 5 (2), 171-180.
- Westphal, J., 2000. *Komplexitätsmanagement in der Produktionslogistik*. Wiesbaden: Universität Wiesbaden.

- Whetten, D., Aldrich, H., 1979. Organization set size and diversity: Links between people processing organizations and their environments. *Administration and Society*, 11, 251-281.
- Whitten, K., Gailey, K., 1984. *General Chemistry*, 2nd ed. Saunders, Toronto, 974.
- Whitten, D., Green, K., Zelbst, P., 2012. Triple-A supply chain performance. *International Journal of Operations & Production Management* 32 (1), 28-48.
- Wieland, A., Wallenburg, C.M., 2012. Dealing with supply chain risks: Linking risk management practices and strategies to performance. *International Journal of Physical Distribution & Logistics Management* 42 (10), 887-905.
- Wildemann, H., 1999. Komplexität vermeiden oder beherrschen lernen. *Harvard Business Manager* 21, 599-616.
- Wildemann, H., 2000. Komplexitätsmanagement: Vertrieb, Produkte, Beschaffung, F&E, Produktion, Administration, TCW Report -1st edition, TCW Transfer-Centrum GmbH, Munich.
- Wildemann, H., 2006. Leitfaden zum Einsatz von E-Technologien in der Wertschöpfungskette, Munich.
- Wilding, R., 1998. The supply chain complexity triangle: uncertainty generation in the supply chain. *International Journal of Physical Distribution and Logistics Management* 28 (8), 599-616.
- Winkler, M., Mey, M., 1994. Holonic manufacturing systems. *European Production Engineering* 18 Nos 3/4, 10-12.
- Wong, C., Lai K., Bernroider, E., 2015. The performance of contingencies of supply chain information integration: The roles of product and market complexity. *International Journal of Production Economics* 165, 1-11.
- Yates, F. E., 1978. Complexity and its limits to knowledge. *American Journal of Physiology – Regulatory, Integrative and Comparative Physiology* 235 (5), R 201-R204.
- Yauch, C.A., Steudel, H.J., 2002. Cellular manufacturing for small businesses: key cultural factors that impact the conversion process. *Journal of Operations Management* 20 (5), 593-617.
- Yin, R.K., 2014. *Case Study Research. Design and Methods*. Fifth ed. Sage, Newbury Park, CA.
- Yusuf, Y., Gunasekaran, A., Musa, A., Dauda, M., El-Berishy, N., Cang, S., 2014. A relational study of supply chain agility, competitiveness and business

- performance in the oil and gas industry. *International Journal of Production Economics* 147, 531-543.
- Zacharia, Z., Nix, N., Lusch, R., 2011. Capabilities that enhance outcomes of an episodic supply chain collaboration. *Journal of Operations Management* 29 (6), 591-603.
- Zammuto, R.F., O'Connor, E.J., 1992. Gaining advanced manufacturing technologies' benefits: the roles of organizational design and culture. *The Academy of Management Review* 17 (4), 701-728.
- Zeigler, B.P., Praehofer, H., Kim, T.G., 2000. *Theory of Modelling and Simulation*, 2nd edition Academic Press, San Diego.
- Zhang, Q., Vonderembse, M.A., Lim, J., 2002. Value chain flexibility: a dichotomy of competence and capability. *International Journal of Production Research* 40 (3), 561-583.
- Zhang, Q., Vonderembse, M.A., Lim, J., 2003. Manufacturing flexibility: defining and analyzing relationships among competence, capability and customer satisfaction. *Journal of Operations Management* 21 (2), 173-191.
- Zhou, D., 2002. *An Empirical Study of the Role of Postponement Application in Reducing Supply Chain Complexity*. Engineering Management Conference. Institute for Manufacturing, Cambridge University, Mill Lane, Cambridge.
- Zhu, Q., Sarkis, J., Kee-hung L., 2013. Institutional-based antecedents and performance outcomes of internal and external green supply chain management practices. *Journal of Purchasing & Supply Chain Management* 19, 106-117.
- Zsidisin, G.A., Managerial Perceptions of Supply Risk. *Journal of Supply Chain Management* 39 (4), 14-26.
- Zsidisin, G.A., Ellram, J.R., Carter, J.R., Cavinato, J.L., 2004. An analysis of supply risk assessment techniques. *International Journal of Physical Distribution & Logistics Management* 34 (5), 397-413.