

The Steiner Connectivity Problem

Ralf Borndörfer* Marika Neumann* Marc Pfetsch†

Abstract

The Steiner connectivity problem is a generalization of the Steiner tree problem. It consists in finding a minimum cost set of simple paths to connect a subset of nodes in an undirected graph. We show that important polyhedral and algorithmic results on the Steiner tree problem carry over to the Steiner connectivity problem, namely, the Steiner cut and the Steiner partition inequalities, as well as the associated polynomial time separation algorithms, can be generalized. Similar to the Steiner tree case, a certain directed formulation, which is stronger than the natural undirected one, plays a central role.

1 Introduction

The *Steiner connectivity problem* (SCP) can be described as follows. We are given an undirected graph $G = (V, E)$, a set of *terminal nodes* $T \subseteq V$, and a set of (simple) *paths* \mathcal{P} in G . The paths have nonnegative costs $c \in \mathbb{R}_+^{\mathcal{P}}$. The problem is to find a set of paths $\mathcal{P}' \subseteq \mathcal{P}$ of minimal cost $\sum_{p \in \mathcal{P}'} c_p$ that connect the terminals, i.e., such that for each pair of distinct terminal nodes $t_1, t_2 \in T$ there exists a path from t_1 to t_2 in G that is completely covered by paths of \mathcal{P}' . We can assume w.l.o.g. that G does not contain edges that are not covered by any path of \mathcal{P} , i.e., for every $e \in E$ there is a $p \in \mathcal{P}$ such that $e \in p$. Figure 1 gives an example of a Steiner connectivity problem (left) and a feasible solution (right).

SCP is a generalization of the *Steiner tree problem* (STP), in which all paths

*Supported by the DFG Research Center MATHEON “Mathematics for key technologies”
Address of the authors: Zuse Institute Berlin, Takustr. 7, 14195 Berlin, Germany;
Email <mailto:borndoerfer@zib.de>, <mailto:marika.neumann@zib.de>

†TU Braunschweig, Institute for Mathematical Optimization, Pockelsstr. 14, 38106
Braunschweig, Germany; Email <mailto:m.pfetsch@tu-bs.de>

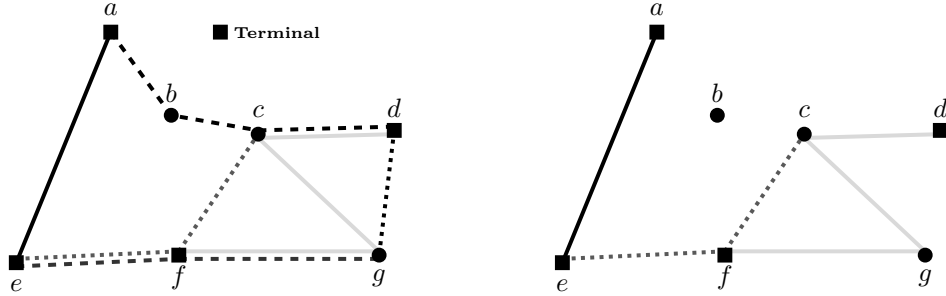

Figure 1: Example of a Steiner connectivity problem. *Left:* A graph with four terminal nodes and six paths ($p_1 = (a, b, c, d)$, $p_2 = (e, f, g)$, $p_3 = (a, e)$, $p_4 = (e, f, c)$, $p_5 = (g, d)$, $p_6 = (f, g, c, d)$). *Right:* A feasible solution with three paths (p_3, p_4, p_6).

contain exactly one edge. Similar to the STP with nonnegative costs, see [10, 12, 13] for an overview, there exists always an optimal solution of the SCP that is *minimally connected*, i.e., if we remove a path from the solution, there exist at least two terminals which are not connected. However, in contrast to the STP, there is not necessarily an optimal solution of the Steiner connectivity problem that forms a tree, see again the right of Figure 1.

SCP is a special case of the *line planning problem*, see [2] and the references therein for a detailed description. The line planning problem can be defined as follows: We are given a public transportation network $G = (V, E)$, a set of (simple) line paths \mathcal{P} , and a passenger demand matrix $D \in \mathbb{N}^{V \times V}$, which gives the number of passengers who want to travel between different stations in the network. The edges of G have nonnegative travel times $\tau \in \mathbb{R}_+^E$, the paths have nonnegative costs $c \in \mathbb{R}_+^{\mathcal{P}}$ and capacities $\kappa \in \mathbb{R}_+^{\mathcal{P}}$. The problem is to find a set of line paths $\mathcal{P}' \subseteq \mathcal{P}$ with associated frequencies $f_p \in \mathbb{R}_+$, $p \in \mathcal{P}'$, and a passenger routing, such that the overall capacities $\sum_{p \in \mathcal{P}', e \in p} f_p \cdot \kappa_p$ on the edges suffice to transport all passengers. There are two possible objectives: to minimize the travel time, or to minimize the cost of the line paths.

The connection between the line planning problem and the SCP is that the line paths \mathcal{P}' usually connect all stations with positive supply and/or demand. More precisely, let (T, F) be the *demand graph* of the line planning problem, where $T = \{v \in V \mid \sum_u (d_{uv} + d_{vu}) > 0\}$ is the set of nodes with positive supply or demand, and $F = \{\{u, v\} \mid d_{uv} + d_{vu} > 0\}$ a set of *demand edges*. Then the following holds: If the demand graph is connected, then the set of line paths \mathcal{P}' of a solution of the line planning problem is a solution of

the SCP associated with the graph G , terminal set T , and costs c . In other words, if we neglect travel times of the passengers, as well as capacities and frequencies of the lines, the line planning problem with connected demand graph reduces to the Steiner connectivity problem, i.e., the SCP captures the connectivity aspect of the line planning problem. This connection motivates the study of the SCP.

A natural question is whether one can transfer structural results and algorithms from the Steiner tree problem to the Steiner connectivity problem. It will turn out that this can indeed be done in many cases. In particular, an important result (see Chopra and Rao [3]) in the STP literature states that the undirected IP formulation of the STP, including all so-called Steiner partition inequalities, is dominated by a certain family of directed formulations. Using this connection, a super class of the Steiner partition inequalities can be separated in polynomial time. We will show that similar results hold for the SCP as well. The directed formulation that we use, however, is constructed in a different way and must be strengthened by so-called flow-balance constraints. Subtle differences also come up in the complexity analysis. For instance, the SCP is also solvable in polynomial time for a fixed number of terminals, but it is NP-hard in the case $T = V$.

The article is structured as follows. It starts with a combinatorial discussion of the Steiner connectivity problem in Section 2. We show that the SCP is equivalent to a suitably constructed directed Steiner tree problem. This construction yields polynomial time algorithms for the SCP in some cases. In Section 3, we give three integer programming formulations for the SCP based on the transformation in Section 2, namely, an undirected cut formulation, a directed cut formulation, and a contracted directed cut formulation. We compare these formulations and their LP relaxations. An analysis of the polytope associated with the undirected cut formulation follows in Section 4. We prove a TDI result for the two terminal case and state necessary and sufficient conditions for the Steiner partition inequalities to be facet defining. We also derive a polynomial time separation algorithm for a super class of the Steiner partition inequalities. This algorithm is based on the directed cut formulation of the SCP. This shows that directed models provide tight formulations for the SCP, similar as for the STP.

2 Relation to Directed Steiner Trees & Complexity

We show in this section the equivalence of the SCP and a suitably constructed directed Steiner tree problem. The *directed Steiner tree problem* (DSTP) is the following: Given a directed graph and a set of terminal nodes T , we have to find a minimum cost set B of arcs that connect a so-called *root node* $r \in T$ to each other terminal $t \in T \setminus \{r\}$, i.e., there exists a directed path from r to t in B . If the costs of the arcs are nonnegative, which we assume, there exists a solution that is a directed tree (an arborescence).

Consider an SCP with undirected graph $G = (V, E)$, a set of paths \mathcal{P} , terminals $T \subseteq V$, and nonnegative costs $c \in \mathbb{R}_+^{\mathcal{P}}$. We construct for this problem an *associated directed Steiner tree problem* as follows. Define a digraph $D' = (V', A')$, which we call *Steiner connectivity digraph*. Its node set is

$$V' := T \cup \{v_p, w_p \mid p \in \mathcal{P}\}.$$

We choose some terminal node $r \in T$ as root node and define the following arcs $a \in A'$ and costs c'_a :

$$\begin{aligned} a &= (r, v_p), & c'_a &:= 0, & \forall p \in \mathcal{P} \text{ with } r \in p, \\ a &= (v_p, w_p), & c'_a &:= c_p, & \forall p \in \mathcal{P}, \\ a &= (w_{\tilde{p}}, v_p), & c'_a &:= 0, & \forall p, \tilde{p} \in \mathcal{P}, p \neq \tilde{p}, p \text{ and } \tilde{p} \text{ have} \\ & & & & \text{a node } v \in V \text{ in common,} \\ a &= (w_p, t), & c'_a &:= 0, & \forall p \in \mathcal{P}, \forall t \in T \setminus \{r\} \text{ with } t \in p. \end{aligned}$$

Figure 2 illustrates our construction. Note that choosing different root nodes results in different Steiner connectivity digraphs and hence different associated DSTPs. However, we will show in Proposition 2.2 that the solutions of an SCP and its associated DSTPs are all equivalent, independent of the choice of the root node. For ease of notation, we will therefore omit the root node from the notation whenever it plays no role. Polyhedral results can depend on the choice of the root node, see Figure 4 for an example. In such cases we include the root node in the notation.

Lemma 2.1. *A DSTP associated with an SCP has the following properties:*

1. *The only arc with target node w_p is (v_p, w_p) , for all $p \in \mathcal{P}$.*
2. *The only arc with source node v_p is (v_p, w_p) , for all $p \in \mathcal{P}$.*
3. *Each simple directed (r, t) -path, $t \in T \setminus \{r\}$, has the form $(r, v_{p_1}, w_{p_1}, \dots, v_{p_k}, w_{p_k}, t)$, $k \geq 1$. □*

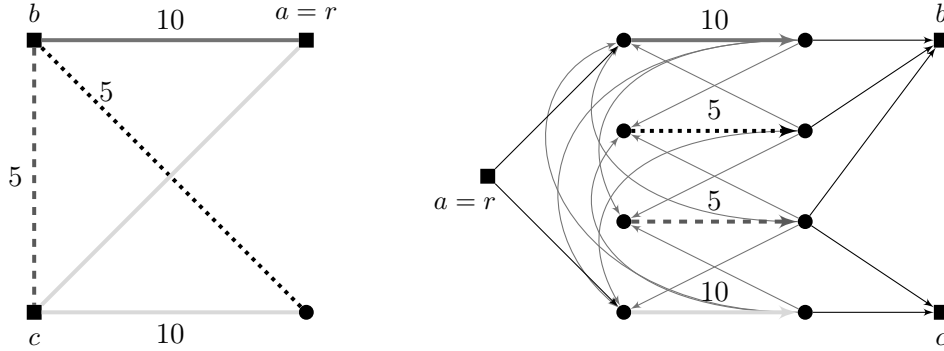

Figure 2: A Steiner connectivity problem and its associated directed Steiner tree problem. *Left:* Graph G with four paths and three terminal nodes. The numbers on the paths indicate costs. *Right:* Associated Steiner connectivity digraph D' . The numbers on the arcs are the costs; arcs with no numbers have zero cost.

Proposition 2.2. *The following holds for an SCP and its associated DSTP: For each solution of one problem there exists a solution of the other problem with the same objective value. In particular, the optimal objective value of an associated DSTP is independent of the choice of the root node.*

Proof. Assume $\tilde{\mathcal{P}}$ is a solution of SCP. Then let

$$\tilde{A} := A' \setminus \{(v_p, w_p) \mid p \notin \tilde{\mathcal{P}}\}.$$

These arcs connect the root r with each terminal $t \in T$ via a directed path. Moreover, $\sum_{a \in \tilde{A}} c'_a = \sum_{p \in \tilde{\mathcal{P}}} c'_{v_p w_p} = \sum_{p \in \tilde{\mathcal{P}}} c_p$.

For the converse, assume that \tilde{A} is a solution of DSTP. We show that

$$\tilde{\mathcal{P}} := \{p \in \mathcal{P} \mid (v_p, w_p) \in \tilde{A}\}$$

is a solution of the corresponding SCP with the same cost. To this purpose, consider the root node r and some terminal $t \in T \setminus \{r\}$; these nodes are connected by a simple directed path in D' using only arcs in \tilde{A} . Each such path has the form $(r, v_{p_1}, w_{p_1}, \dots, v_{p_k}, w_{p_k}, t)$, $k \geq 1$ (see Lemma 2.1), with $(v_{p_i}, w_{p_i}) \in \tilde{A}$, $i = 1, \dots, k$, that is, $p_i \in \tilde{\mathcal{P}}$, $i = 1, \dots, k$. Due to the construction of D' , p_1 contains r , p_i and p_{i+1} , $i = 1, \dots, k-1$, have a node in common, and p_k contains t , i.e., we can find a path from r to t in G that is covered by $p_1, \dots, p_k \in \tilde{\mathcal{P}}$. Since the paths are undirected, every two terminals $t_1, t_2 \in T$, $t_1, t_2 \neq r$, can be connected via r , i.e., $\tilde{\mathcal{P}}$ connects T . The equations $\sum_{p \in \tilde{\mathcal{P}}} c_p = \sum_{p \in \tilde{\mathcal{P}}} c'_{v_p w_p} = \sum_{a \in \tilde{A}} c'_a$ are clear.

The entire proof is independent of the choice of the root node. \square

Since the Steiner connectivity problem is a generalization of the Steiner tree problem, it is strongly NP-hard in general. The relation to the associated DSTP, however, exhibits a number of polynomial cases.

Corollary 2.3. *SCP is solvable in polynomial time for $|T| = k$, k constant.*

Proof. This follows from the complexity results for the directed Steiner tree problem, see Feldman and Ruhl [6], and Proposition 2.2. \square

Note that the case $|T| = 2$ can be solved by a directed shortest path computation.

In contrast to the STP, however, we can show the following.

Proposition 2.4. *SCP is strongly NP-hard for $T = V$, even for unit costs.*

Proof. We reduce the set covering problem to the Steiner connectivity problem. In a set covering problem we are given a finite set S and a set $\mathcal{M} \subseteq 2^S$. The problem is to find a subset $\mathcal{M}' \subseteq \mathcal{M}$ of minimal cardinality $|\mathcal{M}'|$, such that for all $s \in S$ there exists an $M \in \mathcal{M}'$ with $s \in M$.

Given a set covering instance, we define a Steiner connectivity instance in a graph $G = (V, E)$ as follows: The nodes are $V = S \cup \{v\}$ with v being one extra node. Let us write $V = \{s_0, s_1, s_2, \dots\}$, where $v = s_0$. All nodes are terminals. We first assume that G is a complete graph and later remove all edges that are not covered by a path after the construction of the paths. For each set $M \in \mathcal{M}$ order the elements in M arbitrarily and construct a path beginning in node v and passing all nodes of M in the given order. The cost of each such path is 1.

It is easy to see that a cover \mathcal{M}' with at most k elements exists if and only if a set of paths exists that connect all nodes with cost at most k , $k \geq 0$. \square

Corollary 2.5. *SCP is strongly NP-hard for $|T| = |V| - k$, k constant.*

Proof. We can add k isolated nodes to the graph G in the proof of Proposition 2.4. \square

Proposition 2.6. *Unless $P = NP$, there exists no polynomial time α -approximation algorithm for SCP with $\alpha = \gamma \log |V|$, $\gamma \leq 1$.*

Proof. The transformation in Proposition 2.4 is approximation preserving, since there exists a cost preserving bijection between the solutions of a set covering and its corresponding Steiner connectivity instance. It has been shown that the set covering problem is not approximable in the sense that there exists no polynomial time approximation algorithm with approximation factor smaller than logarithmic (in the number of nodes) unless $P = NP$, see Feige [5]. \square

3 Integer Programming Formulations

We propose in this section three integer programming formulations for the SCP. The first one (SCP_{cut}) is a natural cut formulation, the second one (SCP_{arc+}^r) is a directed cut formulation based on the equivalence between the SCP and its associated DSTP, the third one (SCP_{con}^r) is also a directed cut formulation, but in a smaller space. It will turn out that (SCP_{arc+}^r) and (SCP_{con}^r) are equivalent and dominate (SCP_{cut}). (SCP_{arc+}^r) is a common extended formulation of (SCP_{cut}) and (SCP_{con}^r) and, albeit slightly larger than (SCP_{con}^r), is easier to relate to (SCP_{cut}). For this reason, the succeeding sections will refer to (SCP_{arc+}^r).

The section uses the following notation. For a vector $x \in \mathbb{R}^n$, $I \subseteq \{1, \dots, n\}$, let $x|_I = x_I$ be the orthogonal projection of x onto the subspace indexed by I . Let $P_{LP}(F)$ be the polyhedron associated with the LP relaxation of an IP formulation F . Then $P_{LP}(F)|_I$ is the projection of $P_{LP}(F)$ on some subspace of variables indexed by I .

3.1 Cut Formulation

The cut formulation is as follows:

$$\begin{aligned}
 (\text{SCP}_{cut}) \quad & \min \quad \sum_{p \in \mathcal{P}} c_p x_p \\
 \text{(i)} \quad & \text{s.t.} \quad \sum_{p \in \mathcal{P}_{\delta(W)}} x_p \geq 1 \quad \forall \emptyset \neq W \cap T \neq T, W \subseteq V \\
 & \quad \quad \quad x_p \in \{0, 1\} \quad \forall p \in \mathcal{P}.
 \end{aligned}$$

Here, x_p is a 0/1-variable that indicates whether path p is chosen ($x_p = 1$) or not ($x_p = 0$). Furthermore, $\mathcal{P}_{\delta(W)} := \{p \in \mathcal{P} \mid \delta(W) \cap p \neq \emptyset\}$ is the set of all

paths that cross the cut $\delta(W) = \{e \in E \mid |e \cap W| = 1\}$ at least one time. If $\delta(W)$ is an (s, t) -cut for some terminal nodes $s, t \in T$, i.e., if $\emptyset \neq W \cap T \neq T$, we call $\mathcal{P}_{\delta(W)}$ an (s, t) -Steiner path cut or shortly a Steiner path cut, and the inequalities (SCP_{cut})(i) Steiner path cut constraints. If each path has length 1, i.e., contains only one edge, then the sets $\delta(W)$ and $\mathcal{P}_{\delta(W)}$ are equal. In this case the SCP reduces to an STP and the Steiner path cut constraints reduce to the Steiner cut constraints.

Replacing the Steiner path cut constraints by the inequalities

$$\sum_{e \in \delta(W)} \sum_{p: e \in p} x_p \geq 1 \quad \forall \emptyset \neq W \cap T \neq T, W \subseteq V$$

also produces a correct IP formulation of the SCP. These constraints count how often each path crosses the cut $\delta(W)$ and can be seen as a direct generalization of the Steiner cut constraints for the STP. However, these cuts are clearly dominated by the Steiner path cut constraints.

Some Steiner path cut constraints are themselves dominated by others. In fact, the nondominated ones correspond to minimal disconnecting sets. A set \mathcal{P}' is a *disconnecting set* if there exist two terminal nodes which are not connected via $\mathcal{P} \setminus \mathcal{P}'$.

Lemma 3.1. *There is a one-to-one correspondence between minimal sets $\mathcal{P}_{\delta(W)}$ (w.r.t. inclusion), $\emptyset \neq W \cap T \neq T, W \subseteq V$, and minimally disconnecting sets.*

Proof. “ \Leftarrow ”: Let $\mathcal{P}' \subseteq \mathcal{P}$ be a minimally disconnecting set and let $s, t \in T$ be two terminal nodes that are disconnected. Define W to be the nodes reachable from s via $\mathcal{P} \setminus \mathcal{P}'$. Note that $s \in W$ and $t \notin W$, and hence $\mathcal{P}_{\delta(W)}$ is an (s, t) -Steiner path cut. We claim that $\mathcal{P}_{\delta(W)} = \mathcal{P}'$.

Assume $p \in \mathcal{P}_{\delta(W)} \setminus \mathcal{P}'$. Hence, p connects some node u in W to some node $v \in V \setminus W$. By definition of W , $\mathcal{P} \setminus \mathcal{P}'$ connects s and u , and since $p \in \mathcal{P} \setminus \mathcal{P}'$ connects u and v , $\mathcal{P} \setminus \mathcal{P}'$ connects s and v . It follows that $v \in W$, a contradiction. Hence, $\mathcal{P}_{\delta(W)} \subseteq \mathcal{P}'$.

Conversely, assume $p \in \mathcal{P}' \setminus \mathcal{P}_{\delta(W)}$. Since $\mathcal{P}_{\delta(W)} \subseteq \mathcal{P}'$ is a disconnecting set for s and t , it follows that \mathcal{P}' is not minimal, another contradiction.

Finally, $\mathcal{P}_{\delta(W)}$ is minimal w.r.t. inclusion, because otherwise $\mathcal{P}' = \mathcal{P}_{\delta(W)}$ would not be minimally disconnecting.

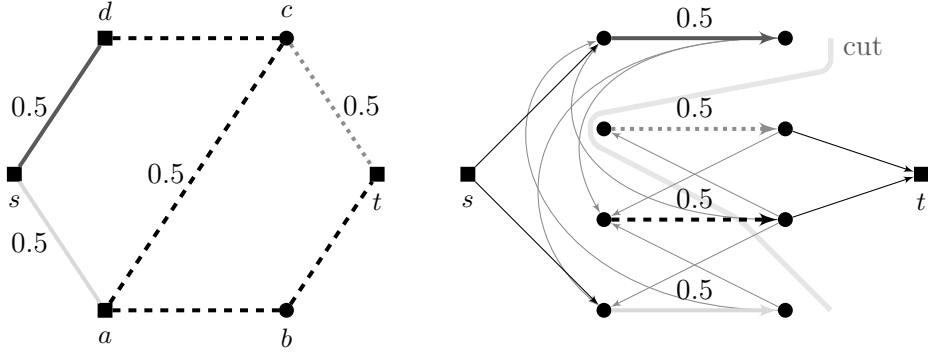

Figure 3: *Left:* Graph G with four paths ($p_1 = (s, d)$, $p_2 = (s, a)$, $p_3 = (d, c, a, b, t)$, $p_4 = (c, t)$) with value 0.5 and two terminal nodes s and t . *Right:* Corresponding directed graph D' . Here, each arc has capacity 0.5 each. The dashed arcs are of the form $(w_{p'}, v_p)$. The minimal (s, t) -cut has value 0.5.

“ \Rightarrow ”: Let $W \subseteq V$ with $\emptyset \neq W \cap T \neq T$, such that $\mathcal{P}_{\delta(W)}$ is minimal w.r.t. inclusion. Then $\mathcal{P}_{\delta(W)}$ is a disconnecting set, because no terminal in W is connected to a terminal in $V \setminus W$ via $\mathcal{P} \setminus \mathcal{P}_{\delta(W)}$. We claim that $\mathcal{P}_{\delta(W)}$ is also a minimally disconnecting set. Suppose not; then there is a some smaller disconnecting set $\mathcal{P}' \subsetneq \mathcal{P}_{\delta(W)}$, which we can assume to be minimal. By the forward direction of the proof, $\mathcal{P}' = \mathcal{P}_{\delta(W')}$ for some set $\emptyset \neq W' \cap T \neq T$. It follows that $\mathcal{P}_{\delta(W')} = \mathcal{P}' \subsetneq \mathcal{P}_{\delta(W)}$, i.e., $\mathcal{P}_{\delta(W)}$ was not minimal w.r.t. inclusion, a contradiction. \square

The number of the Steiner path cut constraints can be exponential in the size of the input. However, the separation problem, i.e., to decide whether a given point \hat{x} is feasible for the LP relaxation of (SCP_{cut}) or to find a violated Steiner path cut constraint, can be solved in polynomial time. Namely, this problem can be formulated as a family of max flow/min cut problems in the Steiner connectivity digraph $D' = (V', A')$ that was defined in Section 2. Consider some nonnegative vector $\hat{x} \geq 0$. We define the following arc capacities c_a for D' :

$$\begin{aligned}
 a = (r, v_p), & \quad c_a := \hat{x}_p, & \quad \forall p \in \mathcal{P} \text{ with } r \in p, \\
 a = (v_p, w_p), & \quad c_a := \hat{x}_p, & \quad \forall p \in \mathcal{P}, \\
 a = (w_{\tilde{p}}, v_p), & \quad c_a := \min\{\hat{x}_p, \hat{x}_{\tilde{p}}\} & \quad \forall p, \tilde{p} \in \mathcal{P}, p \neq \tilde{p}, p \text{ and } \tilde{p} \text{ have} \\
 & & \quad \text{a node } v \in V \text{ in common,} \\
 a = (w_p, t), & \quad c_a := \hat{x}_p, & \quad \forall p \in \mathcal{P}, \forall t \in T \setminus \{r\} \text{ with } t \in p.
 \end{aligned}$$

Figure 3 illustrates this construction. The following holds.

Lemma 3.2. *Let $t \in T \setminus \{r\}$ be a terminal node. There exists a directed (r, t) -cut with minimum capacity in D' such that all arcs over this cut are of the form (v_p, w_p) , $p \in \mathcal{P}$.*

Proof. Let $\delta^-(W)$ be a directed (r, t) -cut with $W \subseteq V \setminus \{r\}$. We show that we can convert this cut into the required form such that the resulting cut $\delta^-(\tilde{W})$ has weight not larger than $\delta^-(W)$. If $\delta^-(W)$ has minimum capacity then $\delta^-(\tilde{W})$ has minimum capacity as well.

Assume $(r, v_p) \in \delta^-(W)$, i.e., $v_p \in W$. We set $\tilde{W} = W \setminus \{v_p\} \cup \{w_p\}$ and get $\delta^-(\tilde{W}) \subseteq \delta^-(W) \setminus \{(r, v_p)\} \cup \{(v_p, w_p)\}$, because (v_p, w_p) is the only arc with source node v_p and target node w_p (statements 1 and 2 of Lemma 2.1). Furthermore, $(v_p, w_p) \in \delta^-(\tilde{W})$ and $c_{rv_p} = c_{v_p w_p}$. Hence, $\delta^-(\tilde{W})$ has capacity not larger than $\delta^-(W)$.

If $(w_p, t) \in \delta^-(W)$ we set $\tilde{W} = W \setminus \{v_p\} \cup \{w_p\}$ and argue as above.

Assume $(w_{\tilde{p}}, v_p) \in \delta^-(W)$, $p \neq \tilde{p}$, and $\hat{x}_p \leq \hat{x}_{\tilde{p}}$. In this case, we set $\tilde{W} = W \setminus \{v_p\} \cup \{w_p\}$ and get $\delta^-(\tilde{W}) \subseteq \delta^-(W) \setminus \{(w_{\tilde{p}}, v_p)\} \cup \{(v_p, w_p)\}$, again because of statement 1 and 2 of Lemma 2.1. Furthermore, $(v_p, w_p) \in \delta^-(\tilde{W})$ and $c_{v_p w_p} = c_{w_{\tilde{p}} v_p}$. Hence, $\delta^-(\tilde{W})$ has capacity not larger than $\delta^-(W)$. In the case of $\hat{x}_{\tilde{p}} \leq \hat{x}_p$, we set $\tilde{W} = W \setminus \{v_{\tilde{p}}\} \cup \{w_{\tilde{p}}\}$ and argue similarly.

All steps can be repeated until the cut has the desired form. □

We call a cut of the form of Lemma 3.2 a *standard cut*. For given \hat{x} , the *capacity of a Steiner path cut P'* is $\sum_{p \in P'} \hat{x}_p$.

Proposition 3.3. *There is a one-to-one correspondence between minimum capacity (r, t) -Steiner path cuts in G and minimum capacity directed (r, t) -standard cuts in D' , and the capacities are equal.*

Proof. We first show that every directed (r, t) -standard cut $\delta^-(W')$ in D' gives rise to an (r, t) -disconnecting set

$$\mathcal{P}' = \{p \in \mathcal{P} \mid (v_p, w_p) \in \delta^-(W')\}$$

in G . Assume there exists a path from r to t in G that is covered by paths in $\mathcal{P} \setminus \mathcal{P}'$ (i.e., \mathcal{P}' is not a disconnecting set). Let p_1, \dots, p_k be the paths that are used in this order when traversing the path. Then $(r, v_{p_1}, w_{p_1}, \dots, v_{p_k}, w_{p_k}, t)$ is a path from r to t in D' . This is a contradiction to the assumption that $\delta^-(W')$ is a directed (r, t) -standard cut in D' .

Conversely, let \mathcal{P}' be an (r, t) -disconnecting set in G and define

$$W' = \{t\} \cup \{w_p \mid p \in \mathcal{P}'\} \cup W'',$$

where W'' is the set of nodes from which t can be reached via arcs in the set $A' \setminus \{(v_p, w_p) \mid p \in \mathcal{P}'\}$. Then we show that

$$\delta^-(W') = \{(v_p, w_p) \mid p \in \mathcal{P}'\},$$

which is a directed (r, t) -standard cut in D' . It is clear that $\delta^-(W') \supseteq \{(v_p, w_p) \mid p \in \mathcal{P}'\}$.

Assume $(r, v_p) \in \delta^-(W')$ for some $p \in \mathcal{P}$. If $p \in \mathcal{P}'$ then $v_p \notin W'$, a contradiction. If $p \notin \mathcal{P}'$ then t can be reached from v_p via arcs in $A' \setminus \{(v_p, w_p) \mid p \in \mathcal{P}'\}$. Hence, there is a (r, t) -path covered by $p \in \mathcal{P} \setminus \mathcal{P}'$, a contradiction.

Assume $(w_p, t) \in \delta^-(W')$ for some $p \in \mathcal{P}$. For both cases $p \in \mathcal{P}'$ and $p \notin \mathcal{P}'$ we have $w_p \in W'$, a contradiction.

Assume $(v_p, w_p) \in \delta^-(W')$ for some $p \in \mathcal{P} \setminus \mathcal{P}'$. Then $w_p \in W'$, but $v_p \notin W'$, a contradiction.

Assume $(w_{\tilde{p}}, v_p) \in \delta^-(W')$ for some $p, \tilde{p} \in \mathcal{P}$. Then $w_{\tilde{p}} \notin W$ and $v_p \in W$. This implies that t can be reached from v_p via arcs in $A' \setminus \{(v_p, w_p) \mid p \in \mathcal{P}'\}$. But then t can also be reached from $w_{\tilde{p}}$ via arcs in $A' \setminus \{(v_p, w_p) \mid p \in \mathcal{P}'\}$, a contradiction.

It can easily be seen that in both cases \mathcal{P}' and $\delta^-(W')$ have the same capacity. □

Theorem 3.4. *The separation problem for Steiner path cut constraints can be solved in polynomial time.*

Proof. Computing for every two terminals $s, t \in T$ a minimum (s, t) -cut in D' , using s as root node, can be done in polynomial time. If and only if the value of this cut is smaller than 1, we can find a violated Steiner path cut constraint via Proposition 3.3. This can also be done in polynomial time. □

3.2 Directed Cut Formulation

Our second formulation of the SCP is the well-known directed cut formulation for the associated DSTP [3]:

$$\begin{aligned}
 (\text{SCP}_{arc}) \quad & \min \quad \sum_{a \in A'} c'_a y_a \\
 \text{(i)} \quad & \text{s.t.} \quad \sum_{a \in \delta^-(W)} y_a \geq 1 \quad \forall W \subseteq V' \setminus \{r\}, W \cap T \neq \emptyset \\
 & \quad \quad \quad y_a \in \{0, 1\} \quad \forall a \in A'.
 \end{aligned}$$

Note that the solutions of (SCP_{arc}) are supersets of directed Steiner trees for terminal set T . The separation problem for the *directed Steiner cut constraints* (SCP_{arc}) (i) consists of solving $|T| - 1$ min-cut problems, i.e., for each $t \in T \setminus \{r\}$ one has to find a minimum (r, t) -cut in D' . This can be done in polynomial time.

(SCP_{arc}) can be interpreted as an extended formulation of (SCP_{cut}) by identifying arcs (v_p, w_p) and paths $p \in \mathcal{P}$. We define

$$A'_{\mathcal{P}} = \{(v_p, w_p) \in A' \mid p \in \mathcal{P}\}.$$

Then, if y is a solution of (SCP_{arc}) , its projection on the subspace of “path-arcs” $(y_a)_{A'_{\mathcal{P}}} = (y_{v_p w_p})_{p \in \mathcal{P}}$ gives rise to a solution $x = y|_{A'_{\mathcal{P}}}$ of (SCP_{cut}) via $x_p = y_{v_p w_p}$, $p \in \mathcal{P}$. We also write $y|_{A'_{\mathcal{P}}} = y|_{\mathcal{P}}$ to simplify the notation.

We now relate the solutions of the LP relaxations of (SCP_{cut}) and (SCP_{arc}) .

Lemma 3.5. $P_{LP}(\text{SCP}_{cut}) = P_{LP}(\text{SCP}_{arc})|_{\mathcal{P}}$.

Proof. Let $\hat{y} \in P_{LP}(\text{SCP}_{arc})$, i.e., \hat{y} satisfies all directed (r, t) -Steiner path cuts for some root r and every terminal $t \in T \setminus \{r\}$. By Proposition 3.3, $\hat{y}|_{\mathcal{P}}$ satisfies all (r, t) -Steiner path cuts for every terminal $t \in T \setminus \{r\}$. Since paths and cuts are undirected in the SCP, $\hat{y}|_{\mathcal{P}}$ satisfies also all (s, t) -Steiner path cuts for all $s, t \in T \setminus \{r\}$, i.e., $\hat{y}|_{\mathcal{P}} = \hat{x} \in P_{LP}(\text{SCP}_{cut})$.

Let $\hat{x} \in P_{LP}(\text{SCP}_{cut})$, in particular, \hat{x} satisfies all (s, t) -Steiner path cuts for all $s, t \in T$ and hence all (r, t) -Steiner path cuts for some fixed root r . We define $\hat{y} \in \mathbb{R}^{A'}$ by setting $\hat{y}|_{\mathcal{P}} = \hat{x}$ and $\hat{y}|_{A' \setminus A'_{\mathcal{P}}} = \mathbb{1}$. By Proposition 3.3, the vector \hat{y} satisfies all directed (r, t) -standard cuts. All other cuts contain at least one arc with value 1 and are therefore satisfied, i.e., $\hat{y} \in P_{LP}(\text{SCP}_{arc})$. \square

Corollary 3.6. *The optimal objective values of the LP relaxations of (SCP_{arc}) and (SCP_{cut}) are equal. In particular the objective value of the LP relaxation of (SCP_{arc}) is independent of the choice of the root node r .*

Proof. This follows by Lemma 3.5 since $c'|_{\mathcal{P}} = c$, $c'|_{A' \setminus A_p} = 0$. □

In contrast to the Steiner tree problem, where the directed formulation dominates the undirected formulation immediately, the undirected and directed cut formulation for the SCP are equivalent in terms of quality and tractability. However, it is known that directed cut formulations for the STP can easily be strengthened by a small number of inequalities that one can write down explicitly. In our case, it will turn out that such a strengthening dominates a large class of facet defining Steiner partition inequalities for the undirected formulation of the SCP, see Section 4.

Since we assume nonnegative costs, there is always an optimal solution of the associated DSTP that is a directed tree. Each non-terminal node that is contained in such a cost minimal directed Steiner tree has at least one outgoing arc and at most one incoming arc. Therefore, the so-called *flow balance inequalities* are valid for (SCP_{arc}) :

$$\sum_{a \in \delta^-(v)} y_a \leq \sum_{a \in \delta^+(v)} y_a \quad \forall v \in V' \setminus T.$$

These inequalities have been studied for the Steiner tree problem in the context of certain flow formulations, see Polzin [10, 11]. Because of the special form of the Steiner connectivity digraph and the objective function, it suffices to consider the flow balance constraints only for the nodes v_p , $p \in \mathcal{P}$. Adding the flow balance constraints produces the following strengthened formulation of (SCP_{arc}) :

$$\begin{aligned} (\text{SCP}_{arc+}^r) \quad & \min \quad \sum_{a \in A'} c'_a y_a \\ & \text{s.t.} \quad \sum_{a \in \delta^-(W)} y_a \geq 1 \quad \forall W \subseteq V' \setminus \{r\}, W \cap T \neq \emptyset \\ & \quad y_{v_p w_p} \geq \sum_{a \in \delta^-(v_p)} y_a \quad \forall (v_p, w_p) \in A' (p \in \mathcal{P}) \\ & \quad y_a \in \{0, 1\} \quad \forall a \in A'. \end{aligned}$$

Remark. The objective value of the LP relaxation of (SCP_{arc+}^r) is not independent of the choice of the root node, see Figure 4.

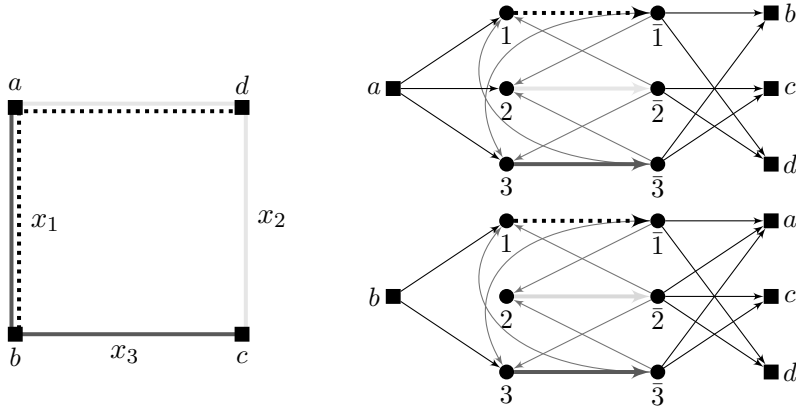

Figure 4: An SCP instance showing that choosing different roots leads to different solutions of the LP relaxation of (SCP_{arc+}^a) . Choosing node a as root allows to set all path values to 0.5. This solution is not possible for (SCP_{arc+}^b) when choosing node b as root.

Remark. The solutions of (SCP_{arc+}^r) are branchings that contain a directed Steiner tree for terminal set T plus possible additional arcs that enter the terminals $T \setminus \{r\}$. Since (SCP_{arc}) always has an optimal solution that is a directed Steiner tree, the optimal objective values of (SCP_{arc+}^r) and (SCP_{arc}) are equal.

Corollary 3.7. $P_{LP}(\text{SCP}_{cut}) = P_{LP}(\text{SCP}_{arc})|_{\mathcal{P}} \supseteq P_{LP}(\text{SCP}_{arc+}^r)|_{\mathcal{P}}$. \square

3.3 Contracted Directed Cut Formulation

Considering the intersection graph of the paths and adjoining terminal nodes leads to the third formulation which arises by contracting the “path-arcs” (v_p, w_p) , $p \in \mathcal{P}$, i.e., we consider a contracted Steiner connectivity digraph $D'' = (V'', A'') = D' / \{(v_p, w_p) \mid p \in \mathcal{P}\}$. Let v_p be the node that arises from contracting the arc (v_p, w_p) , i.e., $V'' = V' \setminus \{w_p \mid p \in \mathcal{P}\} = T \cup \{v_p \mid p \in \mathcal{P}\}$. Analogously, we identify arcs in A'' and A' , i.e., $A'' = A' \setminus A'_p$ ($(w_p, v) \in A'$ corresponds to $(v_p, v) \in A''$). D'' can be interpreted as a “terminal and path intersection digraph”. Furthermore, let $c''_{uv} = c_p$ for $v = v_p$, $p \in \mathcal{P}$, and 0 otherwise, i.e., the path costs are shifted to the ingoing arcs of a node v_p .

The contracted directed cut formulation reads as follows:

$$\begin{aligned}
(\text{SCP}_{con}^r) \quad & \min \quad \sum_{a \in A''} c_a'' y_a \\
\text{s.t.} \quad & \sum_{a \in \delta^-(W)} y_a \geq 1 \quad \forall W \subseteq V'' \setminus \{r\}, W \cap T \neq \emptyset \\
& y_a \in \{0, 1\} \quad \forall a \in A''.
\end{aligned}$$

Remark. The solutions of (SCP_{con}^r) are supersets of directed Steiner trees for terminal set T . The optimal objective values of (SCP_{arc+}^r) and (SCP_{con}^r) are equal.

Lemma 3.8. $P_{LP}(\text{SCP}_{con}^r) = P_{LP}(\text{SCP}_{arc+}^r)|_{A''}$.

Proof. “ \supseteq ”: Let $y' \in P_{LP}(\text{SCP}_{arc+}^r)$, i.e., y' satisfies all directed (r, t) -Steiner cuts for root r and each terminal $t \in T \setminus \{r\}$. Consider a directed (r, t) -Steiner cut $B = \delta^-(W'')$ in D'' . Since D'' arises from D' by contracting the path arcs, there exists a set of nodes $W' \subseteq V' \setminus \{r\}$, $t \in W' \cap T$, in D' such that $B = \delta^-(W') \subseteq A'$ (identifying A'' and $A' \setminus A'_{\mathcal{P}}$) is an (r, t) -Steiner cut. Then

$$\sum_{\substack{a \in \delta^-(W') \\ a \in A'}} y'_a \geq 1 \quad \Rightarrow \quad \sum_{\substack{a \in \delta^-(W'') \\ a \in A''}} y''_a \geq 1,$$

i.e., $y'' = y'|_{A''} \in P_{LP}(\text{SCP}_{con}^r)$.

“ \subseteq ”: Let $y'' \in P_{LP}(\text{SCP}_{con}^r)$, i.e., y'' satisfies all directed (r, t) -Steiner cuts for root r and all $t \in T \setminus \{r\}$ in D'' . We define $y \in \mathbb{R}^{A'}$ as follows:

$$y'|_{A''} = y'', \quad y'|_{\mathcal{P}} = \left(\sum_{a \in \delta^-(v_p)} y''_a \right)_{p \in \mathcal{P}}.$$

We show that $y' \in P_{LP}(\text{SCP}_{arc+}^r)$. By definition of y' , the flow balance constraints are satisfied. It remains to show that $\sum_{a \in \delta^-(W')} y'_a \geq 1$ for all (r, t) -Steiner cuts. Let $B = \delta^-(W')$ be an (r, t) -Steiner cut in D' . We have two possible cases: $(v_p, w_p) \notin \delta^-(W')$ for all $p \in \mathcal{P}$ or there exists a $p \in \mathcal{P}$ such that $(v_p, w_p) \in \delta^-(W')$.

Case 1. Let $(v_p, w_p) \notin \delta^-(W')$ for all $p \in \mathcal{P}$, i.e., we have either $v_p, w_p \in W'$ or $v_p, w_p \notin W'$ for each $p \in \mathcal{P}$. Then there exists a set of nodes $W'' \subseteq V'' \setminus \{r\}$, $t \in W'' \cap T$, in D'' such that $B = \delta^-(W'') \subseteq A''$ (identifying A'' and $A' \setminus A'_{\mathcal{P}}$) is an (r, t) -Steiner cut. Then

$$\sum_{\substack{a \in \delta^-(W'') \\ a \in A''}} y''_a \geq 1 \quad \Rightarrow \quad \sum_{\substack{a \in \delta^-(W') \\ a \in A'}} y'_a \geq 1.$$

Case 2. Now let $p \in \mathcal{P}$ such that $(v_p, w_p) \in \delta^-(W')$, i.e., $w_p \in W'$ and $v_p \notin W'$. In this case, we set $\hat{W}' = W' \cup \{v_p\}$ and get a new (r, t) -Steiner cut with $\delta^-(\hat{W}') \subseteq (\delta^-(W') \cup \{(u, v_p) \mid u \in V'\}) \setminus \{(v_p, w_p)\}$. Using $y_{v_p w_p} = \sum_{a \in \delta^-(v_p)} y_a$ as defined above, we get

$$\sum_{a \in \delta^-(W')} y'_a \geq \sum_{a \in \delta^-(\hat{W}')} y'_a.$$

Iterating over all $p \in \mathcal{P}$ such that $(v_p, w_p) \in \delta^-(\hat{W}')$ we get a cut $\delta^-(\tilde{W}')$ in D' that contains no arc (v_p, w_p) for $p \in \mathcal{P}$ and

$$\sum_{a \in \delta^-(W')} y'_a \geq \sum_{a \in \delta^-(\tilde{W}')} y'_a.$$

Analogously to the first case we can find $\tilde{W}'' \subseteq V''$ such that $B = \delta^-(\tilde{W}'')$ is an (r, t) -Steiner cut in D'' . It follows that

$$\sum_{\substack{a \in \delta^-(\tilde{W}'') \\ a \in A''}} y''_a \geq 1 \quad \Rightarrow \quad \sum_{\substack{a \in \delta^-(W') \\ a \in A'}} y'_a \geq 1.$$

This shows the claim. \square

Corollary 3.9. *The optimal objective values of the LP relaxations of (SCP_{con}^r) and (SCP_{arc+}^r) are equal.*

Proof. The proof of Lemma 3.8 shows the following. If y'' is a solution of (SCP_{con}^r) then there exists a solution y' of (SCP_{arc+}^r) that satisfies all flow balance constraints with equality and $y'|_{A''} = y''$. Moreover,

$$\sum_{a \in A''} c''_a y''_a = \sum_{p \in \mathcal{P}} \sum_{a \in \delta^-(v_p)} c''_a y''_a = \sum_{p \in \mathcal{P}} c'_{v_p w_p} y'_{v_p w_p} = \sum_{a \in A'} c'_a y'_a.$$

For an optimization problem O let $v(O)$ be its optimal objective value. Then the above chain of equalities shows $v(\text{SCP}_{con}^r) \geq v(\text{SCP}_{arc+}^r)$.

Conversely, if y' is a solution of (SCP_{arc+}^r) , by Lemma 3.8, $y'' = y'|_{A''}$ is a feasible solution of (SCP_{con}^r) that satisfies

$$\sum_{a \in A'} c'_a y'_a = \sum_{p \in \mathcal{P}} c'_{v_p w_p} y'_{v_p w_p} \geq \sum_{p \in \mathcal{P}} \sum_{a \in \delta^-(v_p)} c''_a y''_a = \sum_{a \in A''} c''_a y''_a.$$

This shows $v(\text{SCP}_{arc+}^r) \geq v(\text{SCP}_{con}^r)$. \square

4 Polyhedral Analysis

In this section, we investigate the Steiner connectivity polytope. We discuss the two terminal case, analyze a class of facet defining Steiner partition inequalities, and discuss the corresponding separation problem. Let

$$P_{\text{SCP}} := \text{conv}\{\mathbf{x} \in \{0, 1\}^{\mathcal{P}} \mid \mathbf{x} \text{ satisfies all Steiner path cut constraints}\}$$

be the *Steiner connectivity polytope*. We assume that the Steiner connectivity polytope is non-empty, i.e., the graph G is connected and each edge is covered by at least one path of \mathcal{P} .

Since $(\text{SCP}_{\text{cut}})$ is a special set covering formulation, the results of Balas and Ng [1] imply:

Lemma 4.1.

1. P_{SCP} is full dimensional if and only if there exists no Steiner path cut $\mathcal{P}_{\delta(W)}$ with $|\mathcal{P}_{\delta(W)}| = 1$, $\emptyset \neq W \cap T \neq T$. We will call such a cut a “Steiner-path-bridge”.

In the following we assume P_{SCP} to be full dimensional.

2. The inequality $x_p \geq 0$ defines a facet of P_{SCP} if and only if $|\mathcal{P}_{\delta(W)}| \geq 3$ for all W with $p \in \mathcal{P}_{\delta(W)}$ and $\emptyset \neq W \cap T \neq T$.
3. All inequalities $x_p \leq 1$ define facets of P_{SCP} .
4. All facet defining inequalities $\alpha^T x \geq \alpha_0$ for P_{SCP} have $\alpha \geq 0$ if $\alpha_0 > 0$.
5. A Steiner path cut inequality for $\emptyset \neq W \cap T \neq T$ is facet defining if and only if the following two properties are satisfied:
 - (a) There exists no W' , $\emptyset \neq W' \cap T \neq T$, such that $\mathcal{P}_{\delta(W')} \subsetneq \mathcal{P}_{\delta(W)}$, i.e., $\mathcal{P}_{\delta(W)}$ is not dominated.
 - (b) For each two W_1, W_2 , $\emptyset \neq W_i \cap T \neq T$, with $|\mathcal{P}_{\delta(W_i)} \setminus \mathcal{P}_{\delta(W)}| = 1$, $i = 1, 2$ and $\mathcal{P}_{\delta(W_1)} \setminus \mathcal{P}_{\delta(W)} = \mathcal{P}_{\delta(W_2)} \setminus \mathcal{P}_{\delta(W)}$, we have

$$|\mathcal{P}_{\delta(W_1)} \cap \mathcal{P}_{\delta(W_2)} \cap \mathcal{P}_{\delta(W)}| \geq 1.$$

6. The only nontrivial facet defining inequalities for P_{SCP} with integer coefficients and righthand side equal to 1 are the Steiner path cut constraints.

4.1 Two Terminal Case

We have seen that the SCP with a fixed number of terminals can be solved in polynomial time. This brings up the question to identify a complete description of the associated polytope. We will give such a characterization for the

two terminal case. In fact, we will show that the inequality system consisting of the Steiner path cut constraints and the nonnegativity constraints is TDI. A linear system $Ax \geq b$ is *totally dual integral* (TDI) if the linear program $\min\{c^T x : Ax \geq b\}$ has an integral optimal dual solution for every integral c for which the linear program has a finite optimum, see, e.g., Cornuéjols [4].

Consider the LP relaxation of (SCP_{cut}) without upper bounds for the case $T = \{s, t\}$:

$$\begin{aligned}
& \min && \sum_{p \in \mathcal{P}} c_p x_p \\
& \text{s.t.} && \sum_{p \in \mathcal{P}_\delta(W)} x_p \geq 1 && \forall s \in W \subseteq V \setminus \{t\} \\
& && x_p \geq 0 && \forall p \in \mathcal{P}.
\end{aligned} \tag{1}$$

Proposition 4.2. *The inequality system of program (1) is TDI.*

Proof. In the following let $c \geq 0$ be integral. It suffices to consider a non-negative cost vector, because if $c_p < 0$ for some $p \in \mathcal{P}$ then program (1) is unbounded, since we can improve the objective infinitely by letting $x_p \rightarrow \infty$.

Consider the dual of program (1):

$$\begin{aligned}
& \max && \sum_{W \in \mathcal{W}} y_W \\
& \text{s.t.} && \sum_{W \in \mathcal{W}: p \in \mathcal{P}_\delta(W)} y_W \leq c_p && \forall p \in \mathcal{P} \\
& && y_W \geq 0 && \forall W \in \mathcal{W},
\end{aligned} \tag{2}$$

where $\mathcal{W} = \{W \subseteq V \setminus \{t\} \mid s \in W\}$.

We use the primal-dual Algorithm 1 to construct solutions x and y for (1) and (2), respectively. In the following we show that x and y are integral, feasible, and the associated objective values are equal.

Consider the nodes $s = v_1, v_2, \dots, v_r = t$ as marked by Algorithm 1 in line 1 and the cuts W_0, \dots, W_{r-1} as constructed in line 1. The following properties are easy to see:

1. $W_i = \{v_1, \dots, v_i\}$ for $i = 1, \dots, r-1$ and $\emptyset = W_0 \subset W_1 \subset \dots \subset W_{r-1}$. For each W_i , $i = 1, \dots, r-1$, we have $s \in W_i$ and $t \notin W_i$, i.e., W_i is an (s, t) -cut.

Algorithm 1: Primal dual algorithm for $|T| = 2$.

Input : A connected graph $G = (V, E)$, a set of paths \mathcal{P} with costs $c \in \mathbb{R}_+^{\mathcal{P}}$ that covers all edges E , two terminal nodes $s, t \in V$.

Output: A set of paths $\mathcal{P}' \subseteq \mathcal{P}$ with minimal costs which connects s and t . Values for x and y of program (1) and (2).

```

1  $d(s) = 0, d(v) = \infty \forall v \in V \setminus \{s\}, p(v) = s, path(v) = \emptyset \forall v \in V$ 
2  $\mathcal{P}' = \emptyset, W_0 = \emptyset, i = 0, \delta_0 = 0, y_W = 0, \forall W \in \mathcal{W}, x_p = 0, \forall p \in \mathcal{P}$ 
3 All nodes are unmarked. All paths are unmarked.
4 while  $\exists$  unmarked node do
5   Find  $v$  with  $d(v) = \min\{d(w) \mid w \text{ unmarked}, d(w) < \infty\}$ 
6   for all unmarked  $p \in \mathcal{P}$  with  $v \in p$  do
7     for all unmarked  $w$  with  $w \in p$  do
8       if  $d(w) > d(v) + c_p$  then
9          $d(w) = d(v) + c_p$ 
10         $p(w) = v$ 
11         $path(w) = p$ 
12      end
13    end
14    mark  $p$ 
15  end
16  mark  $v, v_{i+1} = v$ 
17  if  $v_{i+1} \neq s$  then
18     $y_{W_i} = d(v_{i+1}) - \delta_i$ 
19  end
20  if  $v_{i+1} = t$  then
21    Goto line 1
22  end
23   $W_{i+1} = W_i \cup \{v_{i+1}\}$ 
24   $\delta_{i+1} = d(v_{i+1})$ 
25   $i = i + 1$ 
26 end
27  $k = 1, u_k = t$ 
28 while  $u_k \neq s$  do
29    $\mathcal{P}' = \mathcal{P}' \cup path(u_k)$ 
30    $x_{path(u_k)} = 1$ 
31    $k = k + 1$ 
32    $u_k = p(u_k)$ 
33 end
34 return  $\mathcal{P}'$ 

```

2. $d(v_{i-1}) \leq d(v_i)$ for $i = 1, \dots, r$.
3. $\delta_i \leq d(v_{i+1})$ for $i = 1, \dots, r-1$ (follows from property 2 and line 1).
4. $d(t) < \infty$ (this follows since G is connected and each edge of G is covered by at least one path of \mathcal{P}).

We first show that y is a solution of program (2). Property 3 implies $y \geq 0$. It remains to show that

$$\sum_{W \in \mathcal{W}: p \in \mathcal{P}_\delta(W)} y_W \leq c_p \quad \forall p \in \mathcal{P}. \quad (3)$$

The variables y_W are zero for all $W \neq W_1, \dots, W_{r-1}$. Let $p \in \mathcal{P}$. If $v_i \notin p$ for all $i = 1, \dots, r-1$, then $p \notin \mathcal{P}_\delta(W_i)$, $i = 1, \dots, r-1$, i.e., $\sum_{W \in \mathcal{W}: p \in \mathcal{P}_\delta(W)} y_W = 0 \leq c_p$. Otherwise let i be the minimal index such that $v_i \in p$, i.e., $p \notin \mathcal{P}_\delta(W_j)$ for $j < i$ but $p \in \mathcal{P}_\delta(W_i)$. As long as $p \not\subseteq W_j$ for $j > i$, we have $p \in \mathcal{P}_\delta(W_j)$, and we have $p \notin \mathcal{P}_\delta(W_j)$ for $p \subseteq W_j$. Hence, there is an index ℓ , $i < \ell \leq r-1$, with $p \in \mathcal{P}_\delta(W_j)$ for $i \leq j \leq \ell$ and $p \notin \mathcal{P}_\delta(W_j)$ for $j > \ell$. Then equation (3) becomes:

$$\begin{aligned} \sum_{W \in \mathcal{W}: p \in \mathcal{P}_\delta(W)} y_W &= \sum_{j=i}^{\ell} y_{W_j} \\ &\stackrel{(1.1)}{=} \sum_{j=i}^{\ell} d(v_{j+1}) - \delta_j \\ &\stackrel{(1.1)}{=} \sum_{j=i}^{\ell} d(v_{j+1}) - d(v_j) = d(v_{\ell+1}) - d(v_i) \\ &\leq d(v_i) + c_p - d(v_i) = c_p. \end{aligned}$$

For the last inequality we distinguish the cases $v_{\ell+1} \in p$ and $v_{\ell+1} \notin p$. In the first case $d(v_{\ell+1}) \leq d(v_i) + c_p$, because this value is considered in the distance computation (lines 6 to 11). In the second case, $v_{\ell+1} = v_r = t$ and there exists a node $w \in p$ with $w \notin W_{r-1}$. Since $v_{\ell+1}$ is marked and w not, we have $d(v_{\ell+1}) \leq d(w)$. Since w can be reached from v_i via p we have $d(w) \leq d(v_i) + c_p$. Again, $d(v_{\ell+1}) \leq d(v_i) + c_p$, and Inequality (3) is satisfied.

We now show that x is a solution of program (1). Due to the definition of x we have $x \geq 0$. We have to show that

$$\sum_{p \in \mathcal{P}_\delta(W)} x_p \geq 1 \quad \forall s \in W \subseteq V \setminus \{t\}. \quad (4)$$

Consider the nodes $t = u_1, \dots, u_k = s$ computed in the while loop starting in line 1. Consider an (s, t) -cut $\delta(W)$. Let i be the largest index with $u_i \notin W$ and $u_{i+1} \in W$. This index exists since $u_k = s \in W$ and $u_1 = t \notin W$. Then we have $x_{\text{path}(u_i)} = 1$, $\text{path}(u_i) \in \mathcal{P}_{\delta(W)}$, and Inequality (4) is satisfied.

The objective value of program (2) is

$$\sum_{i=1}^{r-1} y_{W_i} = \sum_{i=1}^{r-1} d(v_{i+1}) - d(v_i) = d(v_r) - d(v_1) = d(t) - d(s) = d(t).$$

Using line 28 to 33 and 8 to 12 in Algorithm 1 we get

$$\begin{aligned} d(t) &= d(u_1) = d(u_2) + c_{\text{path}(u_1)} = d(u_3) + c_{\text{path}(u_2)} + c_{\text{path}(u_1)} = \dots \\ &= d(u_k) + \sum_{i=1}^k c_{\text{path}(u_i)} = 0 + \sum_{p \in \mathcal{P}'} c_p = \sum_{p \in \mathcal{P}} c_p x_p, \end{aligned}$$

i.e., the objective values of (1) and (2) are equal. The integrality of x is obvious. Since c_p is integral, it follows that $d(v_i)$ and δ_i are integral for $i = 1, \dots, r - 1$. Therefore y_{W_i} , $i = 1, \dots, r - 1$, is integral (line 1). This shows the claim. \square

Corollary 4.3. *The inequality system associated with the LP relaxation of $(\text{SCP}_{\text{cut}})$ is TDI.*

Proof. The inequality system associated with the LP relaxation of $(\text{SCP}_{\text{cut}})$ adds upper bounds $x \leq 1$ to the inequality system of program (1); this adds variables z to the dual program. For solutions x and y as constructed by Algorithm 1 (note that $x \leq \mathbb{1}$) the vectors x and $(y, 0)$ are primal and dual integer solutions of the extended systems with the same objective value. \square

Corollary 4.4. *The Steiner connectivity polytope is integral for $|T| = 2$.* \square

Remark. The integrality of the Steiner connectivity polytope follows also from Lemma 3.5 and the fact that the polytope of $(\text{SCP}_{\text{arc}})$ is integral for two terminal nodes (see, e.g., Cornuéjols [4]).

A $(0,1)$ -matrix A is *ideal* if the polytope $\{x \mid Ax \geq \mathbb{1}, 0 \leq x \leq \mathbb{1}\}$ is integral.

Corollary 4.5. *The coefficient matrix A of $(\text{SCP}_{\text{cut}})$ is ideal.* \square

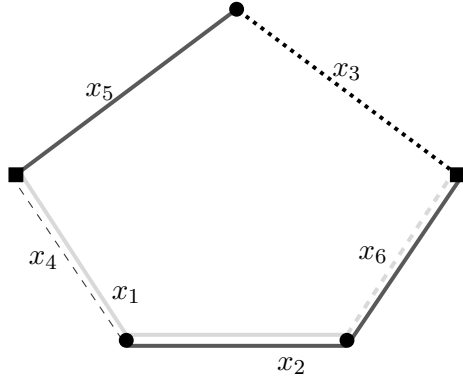

Figure 5: Example of an SCP for which the corresponding coefficient matrix of (SCP_{cut}) is not totally unimodular.

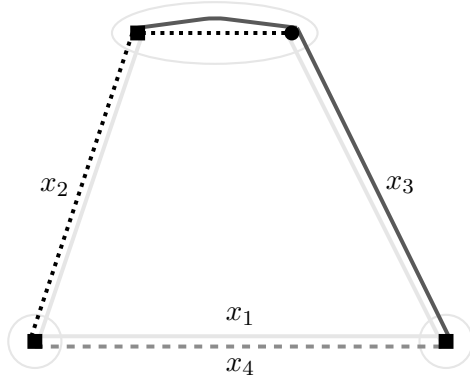

Figure 6: A Steiner partition inequality with three Steiner partitions (encircled): $2x_1 + x_2 + x_3 + x_4 \geq 2$ is facet defining.

Note that the coefficient matrix A of (SCP_{cut}) is not totally unimodular in general, see Figure 5. The coefficient matrix for this example is

$$\begin{pmatrix} 1 & 0 & 1 & 1 & 0 & 0 \\ 0 & 1 & 1 & 0 & 0 & 1 \\ 1 & 1 & 0 & 0 & 1 & 0 \\ 1 & 0 & 0 & 1 & 1 & 0 \\ 1 & 1 & 1 & 0 & 0 & 0 \\ 0 & 1 & 0 & 0 & 1 & 1 \end{pmatrix}.$$

The 3×3 matrix in the upper left corner has determinant -2 and is therefore not totally unimodular. Note that all rows of the matrix correspond to facet defining Steiner path cut constraints.

4.2 Steiner Partition Inequalities

Lemma 4.1 characterizes completely which inequalities of the IP formulation (SCP_{cut}) define facets of the Steiner connectivity polytope. We investigate in this section inequalities arising from node partitions as one important example of an additional class of facets.

Let $P = (V_1, \dots, V_k)$ be a *Steiner partition* of the node set V , i.e., $V_i \cap T \neq \emptyset$ for $i = 1, \dots, k$ and $k \geq 2$. Let $G_P = (V_P, E_P)$ be the graph that arises from contracting each node set V_i to a single node $V_i \in V_P$. Here, we denote by V_i a node set in a partition of G as well as a node in the shrunk graph G_P .

Note that G_P can have parallel edges. Consider a path $p \in \mathcal{P}$: p gives rise to a contracted (not necessarily simple) path in G_P , which we also denote by p . We say that p *contains* V_i , in formulas $V_i \in p$, if p contains a node of V_i . If a path $p \in \mathcal{P}$ contains only a single node of G_P , we also write $V_i \in p$. Furthermore, let \mathcal{P}_P denote the set of paths $p \in \mathcal{P}$ that contain at least two distinct shrunk nodes in G_P , in formulas $\mathcal{P}_P = \{p \in \mathcal{P} \mid \exists V_i, V_j \in V_P, V_i \neq V_j, V_i \in p, V_j \in p\}$.

Lemma 4.6. *The Steiner partition inequality*

$$\sum_{p \in \mathcal{P}_P} a_p \cdot x_p \geq k - 1, \quad (5)$$

$$a_p := |\{V \in V_P : V \in p\}| - 1$$

is valid for the Steiner connectivity polytope P_{SCP} .

An example of a Steiner partition inequality can be seen in Figure 6. Note that the inequality can also be stated as $\sum_{p \in \mathcal{P}} a_p \cdot x_p \geq k - 1$, because $a_p = 0$ for $p \notin \mathcal{P}_P$. If $k = 2$, the partition inequality is a Steiner path cut constraint.

Proof of Lemma 4.6. We have to show that each 0/1-solution x^* of the Steiner connectivity problem satisfies

$$\sum_{p \in \mathcal{P}_P} a_p \cdot x_p^* \geq k - 1.$$

The coefficient a_p , $p \in \mathcal{P}$, counts the number of shrunk nodes that p contains minus one, i.e., a_p is the maximum number of edges that p can contribute to a spanning tree in G_P . Note that the number a_p is in general smaller than the number of times that p crosses the multicut induced by the Steiner partition.

Consider the solution x^* on the shrunk graph G_P . Since each node set V_i , $i = 1, \dots, k$, contains a terminal node, the shrunk graph G_P has to be connected by the solution x^* , i.e., the (paths of the) support of x^* must contain a spanning tree in G_P . This means that the support of x^* contains at least $k - 1$ edges in G_P . \square

The following two propositions give sufficient and necessary conditions for a Steiner partition inequality to be facet defining for the SCP. The sufficient

conditions are analogous to those for the Steiner tree polytope, see Grötschel and Monma [8].

Proposition 4.7. *Let $\overline{\mathcal{P}} := \{p \in \mathcal{P} \mid a_p = 0\} = \mathcal{P} \setminus \mathcal{P}_P$. The Steiner partition inequality is facet defining if the following properties are satisfied.*

1. $G[V_i]$ is connected by $\overline{\mathcal{P}}$, $i = 1, \dots, k$.
2. $G[V_i]$ contains no Steiner-path-bridge in $\overline{\mathcal{P}}$, i.e., there is no Steiner path cut $\mathcal{P}_{\delta(W)} \subseteq \overline{\mathcal{P}}$ with $|\mathcal{P}_{\delta(W)}| = 1$ for $W \subseteq V_i$, $\emptyset \neq W \cap T \neq T \cap V_i$, $i = 1, \dots, k$.
3. Each path contains at most two nodes in G_P , i.e., $a_p \in \{0, 1\}$ for all $p \in \mathcal{P}$.
4. The shrunk graph G_P is 2-path-connected, i.e., if we remove any node with all adjacent paths, the resulting graph is connected. (An edge is removed if it is no longer covered by paths.)

($G[V_i]$ is the graph induced by the node set V_i .)

Proof. Let $P = (V_1, \dots, V_k)$ be a Steiner partition in G and consider the corresponding partition inequality $a^T x = \sum_{p \in \mathcal{P}_P} a_p x_p \geq k - 1$. Assume that properties 1 to 4 are satisfied. Let $b^T x = \beta$ be an equation such that

$$F_a = \{x \in P_{\text{SCP}} \mid a^T x = k - 1\} \subseteq F_b = \{x \in P_{\text{SCP}} \mid b^T x = \beta\},$$

and F_b is a facet of P_{SCP} .

We first show that $b_p = 0$ for all $p \in \overline{\mathcal{P}}$: Since $p \in \overline{\mathcal{P}}$, p is completely contained in $G[V_j]$ for some $j \in \{1, \dots, k\}$. Let $\mathcal{P}' \subseteq \mathcal{P}_P$ be a minimal set of paths connecting G_P , i.e., for each two nodes in G_P there exists a path that is completely covered by paths in \mathcal{P}' and if we remove any path of \mathcal{P}' then there are at least two nodes in G_P that are not connected. Since all paths contain at most two different nodes of G_P (property 3), we have $|\mathcal{P}'| = k - 1$. Set $M = \mathcal{P}' \cup \overline{\mathcal{P}}$ and $M' = M \setminus \{p\}$. Since each $G[V_i]$, $i = 1, \dots, k$, is connected by paths of $\overline{\mathcal{P}}$ (property 1) and p is not a Steiner-path-bridge for $G[V_j]$ (property 2), $\chi^M, \chi^{M'} \in P_{\text{SCP}}$, and $a^T \chi^M = a^T \chi^{M'} = k - 1$, where χ^M is the incidence vector of M . Thus, $b^T \chi^M = b^T \chi^{M'}$ which implies $b_p = 0$.

Let $p, q \in \mathcal{P}_P$, $p \neq q$. Consider the graph $\hat{G}_P = (V_P, \mathcal{P}_P)$, i.e., p is an edge in \hat{G}_P between V_i and V_j if it contains V_i and V_j (recall that $p \in \mathcal{P}_P$ contains exactly two nodes, see property 3). Since G_P is 2-path connected there exists a cycle C in \hat{G}_P containing p and q . Let \mathcal{P}' be a tree in \hat{G}_P containing $C \setminus \{p\}$. Then $\mathcal{P}'' = (\mathcal{P}' \setminus \{q\}) \cup \{p\}$ is also a tree in \hat{G}_P . Set $M = \mathcal{P}' \cup \overline{\mathcal{P}}$ and $M' = \mathcal{P}'' \cup \overline{\mathcal{P}}$. Then $\chi^M, \chi^{M'} \in F_a$ and $0 = b^T \chi^M - b^T \chi^{M'} = b_q - b_p$.

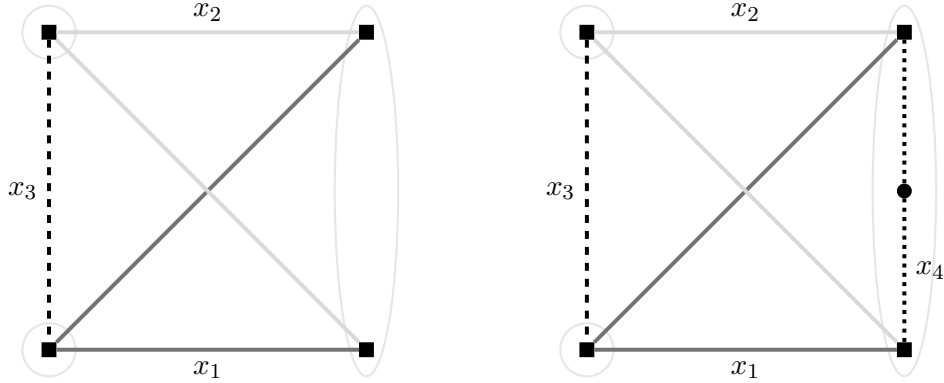

Figure 7: Example that the properties for a facet defining Steiner partition inequality are not necessary in case of the Steiner connectivity problem. In both examples the Steiner partition consists of three node sets which are marked gray. (The square (terminal) nodes have to be connected.)

This implies that $b \in \{0, \lambda\}^{\mathcal{P}}$, $\lambda \geq 0$. Hence, $b^T x$ is a multiple of $a^T x$. This proves that $a^T x \geq k - 1$ defines a facet of P_{SCP} . \square

Different from the Steiner tree problem properties 1 to 3 are not necessary, see Figure 6 (property 3), Figure 7 (left: property 1, right: property 2). Property 4 is necessary, see Proposition 4.8 below.

We now derive necessary conditions. Let $\Phi_{V_i}(\mathcal{P})$ be the set of contracted paths that only contain nodes of the set V_i , i.e., contract the path $p \in \mathcal{P}$ iteratively in the following way until no reduction is possible anymore:

- If p contains the edges $\{u, v\}$ and $\{v, w\}$, and $v \notin V_i$ then contract $\{u, v\}$ and $\{v, w\}$ to $\{u, w\}$.
- If $p = (\{u_1, u_2\}, \{u_2, u_3\}, \dots, \{u_{r-1}, u_r\})$, $r \geq 2$, with $u_1 \notin V_i$ then contract p to $p = (\{u_2, u_3\}, \dots, \{u_{r-1}, u_r\})$.
- If $p = (\{u_1, u_2\}, \{u_2, u_3\}, \dots, \{u_{r-1}, u_r\})$, $r \geq 2$, with $u_r \notin V_i$ then contract p to $p = (\{u_1, u_2\}, \{u_2, u_3\}, \dots, \{u_{r-2}, u_{r-1}\})$.

Proposition 4.8. *If the Steiner partition inequality (5) is facet defining for a Steiner partition P with at least three partition sets, then the following properties have to be satisfied:*

1. *The shrunk graph G_P is 2-path-connected.*
2. *Either $G[V_i]$ is connected or for each two subsets V_i' and V_i'' of V_i ($V_i' \cup V_i'' = V_i$, V_i' is disconnected from V_i'') there exists a path $p \in \mathcal{P}_P$ which contains at least one node of V_i' and one node of V_i'' for all $i = 1, 2, \dots, k$.*

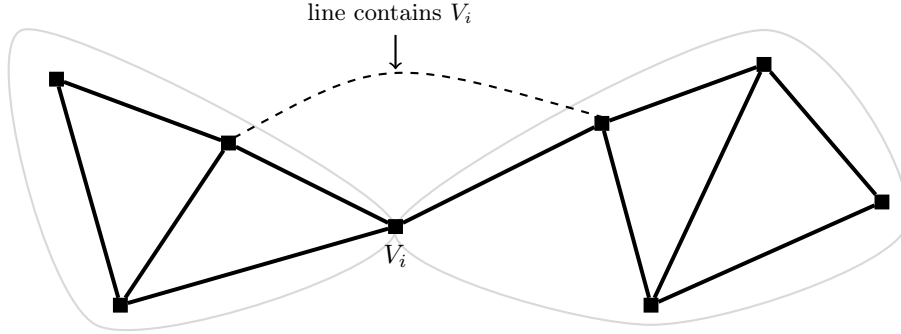

Figure 8: Proposition 4.8 (1) Picture to proof 2-path-connectivity. The graph G_P is not 2-path-connected and V_i is an articulation node. Each path that connects G_1 and G_2 (dashed in the picture) has to contain also V_i .

3. For each $G[V_i]$ the set of paths $\Phi_{V_i}(\mathcal{P})$ does not contain a Steiner path bridge with respect to $G[V_i]$, i.e., if we remove any $\tilde{p} \in \Phi_{V_i}(\mathcal{P})$ then there exist no two terminal nodes in $G[V_i]$ that are not connected by paths of $\Phi_{V_i}(\mathcal{P}) \setminus \{\tilde{p}\}$.
4. If two terminal nodes s and t in some $G[V_i]$ are connected by a path $p' \in \mathcal{P}$, then these terminals must be also connected by $\overline{\mathcal{P}}$ or we can subdivide V_i into V_i' and V_i'' , $V_i = V_i' \cup V_i''$, such that $s \in V_i'$, $t \in V_i''$, and V_i' and V_i'' are not connected by $\overline{\mathcal{P}}$. In this case for each $V_j \in p'$, $V_j \neq V_i$, there exists a $p'' \in \mathcal{P}$ with $V_j \notin p''$, and $V_i' \in p''$, $V_i'' \in p''$.

Proof. In the following let $P = (V_1, \dots, V_k)$ be a Steiner partition with corresponding partition inequality $\sum_{p \in \mathcal{P}_P} a_p x_p \geq k - 1$.

1. Assume G_P is not 2-path-connected. In this case there exists a node V_i in G_P which is an articulation node in the following sense: If V_i and all paths incident to V_i are removed from G_P then the resulting graph is not connected (by the remaining paths). Suppose w.l.o.g. that V_i separates V_1, \dots, V_{i-1} from V_{i+1}, \dots, V_k . Let $G_1 = G_P[V_1, \dots, V_i]$ and $G_2 = [V_i, \dots, V_k]$, see Figure 8. Let k_1 be the number of nodes of G_1 and k_2 be the number of nodes of G_2 . The number of nodes of G_P is k . Note that V_i is node of G_1 and G_2 . Therefore we have $k = k_1 + k_2 - 1$. We construct a smaller Steiner partition $P' = \{V_1 \cup \dots \cup V_{i-1} \cup V_i, \dots, V_k\}$ which contains all nodes of $G_2 \setminus \{V_i\}$ and G_1 as a single node. Let the resulting Steiner partition inequality be $\sum_{p \in \mathcal{P}_{P'}} a'_p x_p \geq k_2 - 1$. Similarly, we construct a Steiner partition $P'' = \{V_1, \dots, V_i \cup V_{i+1} \cup \dots \cup$

$V_k\}$ which contains all nodes of $G_1 \setminus \{V_i\}$ and G_2 as a single node. We get the partition inequality $\sum_{p \in \mathcal{P}_{P''}} a_p'' x_p \geq k_1 - 1$.

The sum of these two partition inequalities is equal to the partition inequality for P . Indeed, $k_1 - 1 + k_2 - 1 = k_1 + k_2 - 2 = k - 1$, and $a_p' + a_p'' = a_p$, see Figure 8. Hence, Inequality (5) does not define a facet.

2. Assume w.l.o.g. $G[V_1]$ is not connected and there exists no path connecting different components of $G[V_1]$. Let $V_1' \subset V_1$ be the node set of one connected component of $G[V_1]$ such that $(V_1 \setminus V_1') \cap T \neq \emptyset$. Since G is connected (and every edge is covered by at least one path) there is a node set V_j , $j \in \{2, \dots, k\}$, say V_2 , such that V_1' and V_2 are connected by a path. We construct a new Steiner partition $P' = (V_1 \setminus V_1', V_1' \cup V_2, V_3, \dots, V_k)$ and get the partition inequality $\sum_{p \in \mathcal{P}_{P'}} a_p' x_p \geq k - 1$. Let $\hat{\mathcal{P}} = \{p \in \mathcal{P}_P \mid V_1' \in p, V_2 \in p\}$, i.e., $\hat{\mathcal{P}}$ contains all paths that connect V_1' and V_2 . One can easily verify that

$$a_p' = \begin{cases} a_p - 1 & \text{if } p \in \hat{\mathcal{P}} \\ a_p & \text{otherwise (since } V_1' \text{ is not connected to } (V_1 \setminus V_1')) \end{cases}$$

Since $|\hat{\mathcal{P}}| \geq 1$, the partition inequality for P is the sum of the partition inequality for P' and the inequality $x_p \geq 0$ for all $p \in \hat{\mathcal{P}}$. Therefore, the partition inequality for P is not facet defining in this case.

3. Assume there is a Steiner path bridge $\tilde{p} \in \Phi_{V_i}(\mathcal{P})$ with respect to $G[V_i]$. Let V_i' and $V_i'' := V_i \setminus V_i'$ be two components of $G[V_i]$ that contain terminal nodes which are only connected by $\tilde{p} \in \Phi_{V_i}(\mathcal{P})$. Then $P' = (V_1, \dots, V_i', V_i'', \dots, V_k)$ is a Steiner partition. Let the corresponding partition inequality be $\sum_{p \in \mathcal{P}_{P'}} a_p' x_p \geq k$.

We claim that this partition inequality plus the upper bound inequality $-x_{\tilde{p}} \geq -1$ of \tilde{p} is equal to the partition inequality for P .

The partition P' only differs from P in splitting the node set V_i . Because \tilde{p} is the only path that connects V_i' and V_i'' , we have $\mathcal{P}_{P'} = \mathcal{P}_P \cup \{\tilde{p}\}$. Furthermore, there is no path in \mathcal{P}_P (except \tilde{p} , if $\tilde{p} \in \mathcal{P}_P$) that contains V_i' and V_i'' . Therefore the coefficients of all these paths stay the same: $a_p = a_p'$ for all $p \in \mathcal{P}_{P'} \setminus \{\tilde{p}\}$. For $\tilde{p} \in \mathcal{P}_P$ we get $a_{\tilde{p}}' = a_{\tilde{p}} + 1$.

4. Assume there are two terminal nodes s and t in $G[V_i]$ that are connected by a path $p' \in \mathcal{P}_P$ and not connected by $\bar{\mathcal{P}}$. Then we can divide V_i into V_i' and V_i'' , $V_i = V_i' \dot{\cup} V_i''$, such that $s \in V_i'$, $t \in V_i''$, and V_i' and V_i'' are not connected by $\bar{\mathcal{P}}$. Furthermore, assume there exists a $V_j \in p'$, $V_j \neq V_i$, and no path $p'' \in \mathcal{P}_P$ such that $V_j \notin p''$, $V_i' \in p''$, and $V_i'' \in p''$. Let w.l.o.g. $V_i = V_1$ and $V_j = V_2$.

We consider the Steiner partition $P' := (V_1', V_1'', V_2, \dots, V_k)$ with partition

inequality $\sum_{p \in \mathcal{P}_{P'}} a'_p x_p \geq k$ and $P'' := (V_1 \cup V_2, V_3, \dots, V_k)$ with partition inequality $\sum_{p \in \mathcal{P}_{P''}} a''_p x_p \geq k - 2$. Then we show that the partition inequality for P multiplied by 2 is dominated by the sum of the partition inequalities for P' and P'' .

Consider the right hand side: $k + k - 2 = 2 \cdot k - 2 = 2 \cdot (k - 1)$. For the coefficients we get:

a'_p = number of visited nodes of p in $\{V_3, \dots, V_k\} + 1$ (if $p \in V'_1$) + 1 (if $p \in V''_1$) + 1 (if $p \in V_2$) - 1

a''_p = number of visited nodes of p in $\{V_3, \dots, V_k\} + 1$ (if $p \in \{V'_1, V''_1, V_2\}$) - 1

Note that our assumptions imply

$$V'_1 \in p \wedge V''_1 \in p \Rightarrow V_2 \in p.$$

We show now that this yields $2 \cdot a_p \geq a'_p + a''_p$:

- $V'_1 \notin p, V''_1 \notin p \Rightarrow a'_p = a''_p = a_p$
- $V'_1 \in p, V''_1 \notin p, V_2 \notin p \Rightarrow a'_p = a''_p = a_p$
- $V'_1 \in p, V''_1 \notin p, V_2 \in p \Rightarrow a'_p = a_p, a''_p = a_p - 1$
- $V'_1 \in p, V''_1 \in p \Rightarrow V_2 \in p \Rightarrow a'_p = a_p + 1, a''_p = a_p - 1$.
- The cases where $V'_1 \notin p$ and $V''_1 \in p$ are similar.

This shows the claim. □

4.3 Separating the Steiner Partition Inequalities

Grötschel, Monma, and Stoer [9] showed that separating the Steiner partition inequalities for the Steiner tree problem is NP-hard. This implies that the separation of the Steiner partition inequalities for the Steiner connectivity problem is also NP-hard. However, we show in the following that the Steiner partition inequalities of SCP are satisfied by all points in $P_{LP}(\text{SCP}_{arc^+}^r)|_{\mathcal{P}}$. This implies that the separation problem for a superclass of Steiner partition inequalities can be solved in polynomial time.

Theorem 4.9. $P_{LP}(\text{SCP}_{arc^+}^r)|_{\mathcal{P}}$ satisfies all Steiner partition inequalities.

Proof. Let $y^* \in P_{LP}(\text{SCP}_{arc^+}^r)$. We show that the projection $x_p^* = y_{v_p w_p}^*$ satisfies all Steiner partition inequalities.

Consider an arbitrary Steiner partition $P = (V_1, \dots, V_k)$ in G and the corresponding partition inequality $\sum_{p \in \mathcal{P}_P} a_p x_p \geq k - 1$. W.l.o.g. we assume

that $r \in V_k$. Consider the following chain of inequalities

$$\sum_{p \in \mathcal{P}_P} a_p x_p^* \stackrel{(1)}{\geq} \sum_{p \in \mathcal{P}_P} a_p \sum_{a \in \delta^-(v_p)} y_a^* \stackrel{(2)}{\geq} \sum_{i=1}^{k-1} \sum_{a \in \delta^-(W_i)} y_a^* \stackrel{(3)}{\geq} k-1,$$

where $W_i := \{t \in T \setminus \{r\} \mid t \in V_i\} \cup \{v_p, w_p \mid V_i \in p\}$, for $i = 1, \dots, k-1$.

Inequality (1) is a summation of flow balance constraints $x_p^* = y_{v_p w_p}^* \geq \sum_{a \in \delta^-(v_p)} y_a^*$.

Inequality (3): Each node set W_i ($i = 1, \dots, k-1$) contains at least one terminal node, but not the root node r . Hence, the arc set $\delta^-(W_i)$ is a directed Steiner cut between root r and W_i . Therefore, $\sum_{a \in \delta^-(W_i)} y_a^* \geq 1$ must hold. Summing over all these cuts gives (3).

Inequality (2): All arcs in the cuts $\delta^-(W_i)$, $i = 1, \dots, k-1$, are of the form $(r, v_p) \in A'$ or $(w_{\tilde{p}}, v_p) \in A'$ for $p, \tilde{p} \in \mathcal{P}$. Denote by $\mathcal{V}_p := \{V_i \mid V_i \in p, i = 1, \dots, k\}$ the set of shrunk nodes contained in p ; then $|\mathcal{V}_p| - 1 = a_p$. The proof proceeds by establishing a relation between a_p and the number of times an arc that enters v_p , appears in the cuts $\delta^-(W_i)$, $i = 1, \dots, k-1$.

Consider an arc $(r, v_p) \in A'$. Then the following chain of equations and inequalities holds

$$a_p = |\mathcal{V}_p| - 1 = |\mathcal{V}_p \setminus \{V_k\}| \geq |\{W_i \mid (r, v_p) \in \delta^-(W_i), i = 1, \dots, k-1\}|. \quad (6)$$

Here, $(r, v_p) \in A'$ implies $V_k \in p$ ($r \in V_k$) and this yields $|\mathcal{V}_p| - 1 = |\mathcal{V}_p \setminus \{V_k\}|$. Moreover, $(r, v_p) \in \delta^-(W_i)$ implies $V_i \in p$. Taking the union for $i = 1, \dots, k-1$ yields $|\mathcal{V}_p \setminus \{V_k\}| \geq |\{W_i \mid (r, v_p) \in \delta^-(W_i), i = 1, \dots, k-1\}|$. Multiplying inequality (6) with $y_{rv_p}^*$ gives

$$\begin{aligned} a_p \cdot y_{rv_p}^* &\geq |\{W_i \mid (r, v_p) \in \delta^-(W_i), i = 1, \dots, k-1\}| \cdot y_{rv_p}^* \\ &= \sum_{i=1}^{k-1} \sum_{(r, v_p) \in \delta^-(W_i)} y_{rv_p}^*. \end{aligned} \quad (7)$$

Consider an arc $(w_{\tilde{p}}, v_p) \in A'$. Then the following chain of equations and inequalities holds

$$a_p = |\mathcal{V}_p| - 1 \geq |\mathcal{V}_p \setminus \mathcal{V}_{\tilde{p}}| \geq |\{W_i \mid (w_{\tilde{p}}, v_p) \in \delta^-(W_i), i = 1, \dots, k-1\}|. \quad (8)$$

Here, $(w_{\tilde{p}}, v_p) \in A'$ implies $\mathcal{V}_p \cap \mathcal{V}_{\tilde{p}} \neq \emptyset$ and this yields $|\mathcal{V}_p| - 1 \geq |\mathcal{V}_p \setminus \mathcal{V}_{\tilde{p}}|$. Moreover, $(w_{\tilde{p}}, v_p) \in \delta^-(W_i)$ implies $V_i \in p$ and $V_i \notin \tilde{p}$. Taking the union for

$i = 1, \dots, k-1$ yields $|\mathcal{V}_p \setminus \mathcal{V}_{\bar{p}}| \geq |\{W_i \mid (w_{\bar{p}}, v_p) \in \delta^-(W_i), i = 1, \dots, k-1\}|$. Multiplying inequality (8) with $y_{w_{\bar{p}}v_p}^*$ gives

$$\begin{aligned} a_p \cdot y_{w_{\bar{p}}v_p}^* &\geq |\{W_i \mid (w_{\bar{p}}, v_p) \in \delta^-(W_i), i = 1, \dots, k-1\}| \cdot y_{w_{\bar{p}}v_p}^* \\ &= \sum_{i=1}^{k-1} \sum_{(w_{\bar{p}}, v_p) \in \delta^-(W_i)} y_{w_{\bar{p}}v_p}^*. \end{aligned} \quad (9)$$

Summing inequalities (7) and (9) over all arcs (r, v_p) and $(w_{\bar{p}}, v_p)$ gives inequality (2):

$$\begin{aligned} \sum_{p \in \mathcal{P}_P} a_p \sum_{a \in \delta^-(v_p)} y_a^* &= \sum_{p \in \mathcal{P}} a_p \sum_{a \in \delta^-(v_p)} y_a^* \\ &= \sum_{(r, v_p) \in A'} a_p \cdot y_{rv_p}^* + \sum_{(w_{\bar{p}}, v_p) \in A'} a_p \cdot y_{w_{\bar{p}}v_p}^* \stackrel{(7) \text{ and } (9)}{\geq} \sum_{i=1}^{k-1} \sum_{a \in \delta^-(W_i)} y_a^*. \end{aligned}$$

This shows the claim. \square

Let $P = \{y \in \mathbb{R}^n \mid Ay \geq b, y \geq 0\}$ be a polyhedron, $I \subseteq \{1, \dots, n\}$, and $x^* \in \mathbb{R}^I$ be a vector. If the optimization problem for P is solvable in polynomial time then the separation problem $x^* \in P|_I$ for the projection is solvable in polynomial time. This follows from the equivalence of optimization and separation and its consequences, see Grötschel, Lovász, and Schrijver [7] (intersect P with the affine space $y|_I = x^*$). Applied to our case, we get the following result.

Proposition 4.10. *The separation problem for $P_{LP}(\text{SCP}_{arc+}^r)|_{\mathcal{P}}$ can be solved in polynomial time. The projection of a violated cutting plane also separates the given point from the Steiner connectivity polytope.*

Proof. The claim follows directly with the argumentation above and the fact that the LP relaxation of (SCP_{arc+}^r) can be solved in polynomial time. In the following, we give a direct algorithm to generate the violated cut.

Let $x^* \in [0, 1]^{\mathcal{P}}$ be the point to be separated and define the arc set $\tilde{A} = \{(v_p, w_p) \in A' \mid p \in \mathcal{P}\}$. Consider the following reformulation of (SCP_{arc+}^r)

with $y|_{\mathcal{P}} = x^* =: y^*$.

$$\begin{aligned}
\sum_{a \in \delta^-(W), a \in A' \setminus \tilde{A}} y_a &\geq 1 - \sum_{a \in \delta^-(W), a \in \tilde{A}} y_a^* \quad \forall W \subseteq V' \setminus \{r\}, W \cap T \neq \emptyset \\
- \sum_{a \in \delta^-(v_p)} y_a &\geq -y_{v_p w_p}^* \quad \forall (v_p, w_p) \in A' (p \in \mathcal{P}) \\
y_a &\geq 0 \quad \forall a \in A' \setminus \tilde{A}.
\end{aligned} \tag{10}$$

The problem is to find a vector $y \in P_{LP}(\text{SCP}_{arc+}^r)$ with $y|_{\mathcal{P}} = x^*$ or to find a separating cutting plane.

Let $\mathcal{W} := \{W \subset V' \setminus \{r\} \mid W \cap T \neq \emptyset\}$. Using the Farkas lemma either inequality system (10) has a solution or the following inequality system has a solution.

$$\begin{aligned}
\sum_{W \in \mathcal{W}} (1 - \sum_{a \in \delta^-(W), a \in \tilde{A}} y_a^*) \cdot \mu_W - \sum_{p \in \mathcal{P}} y_{v_p w_p}^* \pi_p &> 0 \\
\sum_{W \in \mathcal{W}: a \in \delta^-(W)} \mu_W - \sum_{p, a \in \delta^-(v_p)} \pi_p &\leq 0 \quad \forall a \in A' \setminus \tilde{A} \\
\mu_W &\geq 0 \quad \forall W \in \mathcal{W} \\
\pi_p &\geq 0 \quad \forall p \in \mathcal{P}.
\end{aligned} \tag{11}$$

Note that this program can be solved by column generation. The pricing problem for the μ -variables is to find a cut $\delta^-(W)$, $W \subseteq V' \setminus \{r\}$, $W \cap T \neq \emptyset$, with capacity smaller than 1 or to conclude that no such cut exists.

Therefore, if $y \notin P_{LP}(\text{SCP}_{arc+}^r)$ with $y|_{\mathcal{P}} = x^*$ then there exists π^* and μ^* which satisfy (11). In particular, especially, we have

$$\sum_{W \in \mathcal{W}} (1 - \sum_{a \in \delta^-(W), a \in \tilde{A}} y_a^*) \cdot \mu_W^* - \sum_{p \in \mathcal{P}} y_{v_p w_p}^* \pi_p^* > 0.$$

In this case

$$\sum_{W \in \mathcal{W}} \mu_W^* \leq \sum_{W \in \mathcal{W}} \sum_{p: (v_p, w_p) \in \delta^-(W)} \mu_W^* x_p + \sum_{p \in \mathcal{P}} \pi_p^* x_p.$$

is a cutting plane that also separates $x^* = y|_{\mathcal{P}}$ from the Steiner connectivity polytope. \square

Corollary 4.11. *Let $x^* \in P_{LP}(\text{SCP}_{cut})$. If x^* does not satisfy all Steiner partition inequalities then one can construct a cutting plane, that separates x^* from the Steiner connectivity polytope, in polynomial time.*

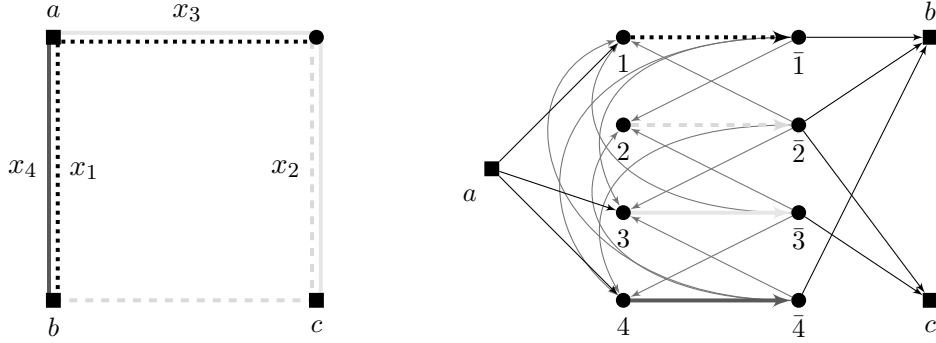

Figure 9: An SCP instance. The inequality $x_1 + x_2 + x_3 + x_4 \geq 2$ is valid but not a partition inequality.

Proof. This follows directly with Theorem 4.9 and Proposition 4.10. \square

Remark (and example). (SCP_{arc+}^r) implicitly contains other constraints that do not correspond to partition inequalities. Figure 9 shows an example. The inequality $x_1 + x_2 + x_3 + x_4 \geq 2$ is valid, but not a partition inequality: We have to find three node sets such that each node set contains at least one terminal node. However, in every possible partition at least one path contains all three partition nodes.

We show that (SCP_{arc+}^r) also satisfies this cut. For the associated directed Steiner tree problem we choose a as root, compare with Figure 9. (Note, when choosing b or c as root node we would also get the above inequality.) Consider the node sets $W_b = \{b, 1, \bar{1}, 2, \bar{2}, 4, \bar{4}\}$ and $W_c = \{c, 2, \bar{2}, 3, \bar{3}\}$. The corresponding (a, b) -cut and (a, c) -cut, respectively, are

$$\begin{aligned} \delta^-(W_b) &= \{(a, 1), (a, 4), (\bar{3}, 1), (\bar{3}, 2), (\bar{3}, 4)\} \quad \text{and} \\ \delta^-(W_c) &= \{(a, 3), (\bar{1}, 2), (\bar{1}, 3), (\bar{4}, 2), (\bar{4}, 3)\}. \end{aligned}$$

If we use the flow balance constraints and the two above defined cuts, we get

$$\begin{aligned} x_1 + x_2 + x_3 + x_4 &= y_{1\bar{1}} + y_{2\bar{2}} + y_{3\bar{3}} + y_{4\bar{4}} \\ &\geq y_{a1} + y_{\bar{2}1} + y_{\bar{3}1} + y_{\bar{4}1} + y_{\bar{1}2} + y_{\bar{3}2} + y_{\bar{4}2} + \\ &\quad y_{a3} + y_{\bar{1}3} + y_{\bar{2}3} + y_{\bar{4}3} + y_{a4} + y_{\bar{1}4} + y_{\bar{2}4} + y_{\bar{3}4} \\ &\geq 2 + y_{\bar{2}1} + y_{\bar{4}1} + y_{\bar{2}3} + y_{\bar{4}3} + y_{\bar{1}4} + y_{\bar{2}4} \geq 2. \end{aligned}$$

For the construction of a violated cut, see proof of Proposition 4.10, let $x^* \in P_{LP}(SCP_{cut})$ with $x_1^* = x_2^* = x_3^* = 0.5$ and $x_4^* = 0$. Obviously x^*

satisfies all Steiner cut inequalities but not $x_1 + x_2 + x_3 + x_4 \geq 2$. Consider inequality set (10) for this example for two selected node sets W .

$$\begin{aligned}
y_{\bar{3}2} &\geq 1 - y_{\bar{1}\bar{1}}^* - y_{\bar{4}\bar{4}}^* & W = \{\bar{1}, 2, \bar{2}, \bar{4}, b\} \\
y_{\bar{1}2} + y_{\bar{4}2} &\geq 1 - y_{\bar{3}\bar{3}}^* & W = \{2, \bar{2}, \bar{3}, c\} \\
-y_{a1} - y_{\bar{2}1} - y_{\bar{3}1} - y_{\bar{4}1} &\geq -y_{\bar{1}\bar{1}}^* \\
-y_{\bar{1}2} - y_{\bar{3}2} - y_{\bar{4}2} &\geq -y_{\bar{2}\bar{2}}^* \\
-y_{a3} - y_{\bar{1}3} - y_{\bar{2}3} - y_{\bar{4}3} &\geq -y_{\bar{3}\bar{3}}^* \\
-y_{a4} - y_{\bar{1}4} - y_{\bar{2}4} - y_{\bar{3}4} &\geq -y_{\bar{4}\bar{4}}^*
\end{aligned}$$

and the corresponding inequality set (11)

$$\begin{aligned}
(1 - y_{\bar{1}\bar{1}}^* - y_{\bar{4}\bar{4}}^*)\mu_1 + (1 - y_{\bar{3}\bar{3}}^*)\mu_2 - \pi_1 \cdot y_{\bar{1}\bar{1}}^* - \pi_2 \cdot y_{\bar{2}\bar{2}}^* - \pi_3 \cdot y_{\bar{3}\bar{3}}^* - \pi_4 \cdot y_{\bar{4}\bar{4}}^* &> 0 \\
\mu_1 - \pi_2 &\leq 0 \\
\mu_2 - \pi_2 &\leq 0 \\
\mu_1, \mu_2 &\geq 0 \\
\pi_i &\geq 0 \quad i = \{1, 2, 3, 4\}.
\end{aligned}$$

A valid solution for this is $\mu_1 = \mu_2 = 1$, $\pi_2 = 1$, and all other variables set to 0. Since $y_{\bar{1}\bar{1}}^* = x_1^* = 0.5$, $y_{\bar{2}\bar{2}}^* = x_2^* = 0.5$, $y_{\bar{3}\bar{3}}^* = x_3^* = 0.5$, and $y_{\bar{4}\bar{4}}^* = x_4^* = 0$, the value of the first inequality is 0.5. Therefore we get as cutting plane

$$(1 - x_1 - x_4) + (1 - x_3) - x_2 \leq 0 \Leftrightarrow x_1 + x_2 + x_3 + x_4 \geq 2.$$

References

- [1] Egon Balas and Shu Ming Ng. On the set covering polytope: I. All the facets with coefficients in $\{0,1,2\}$. *Mathematical Programming*, 43:57–69, 1989.
- [2] Ralf Borndörfer, Martin Grötschel, and Marc E. Pfetsch. A column-generation approach to line planning in public transport. *Transportation Science*, 41(1):123–132, 2007.
- [3] Sunil Chopra and M. Rao. The Steiner tree problem I: Formulations, compositions and extension of facets. *Mathematical Programming*, 64(2):209–229, 1994.
- [4] Gerard Cornuéjols. *Combinatorial Optimization: Packing and Covering*. CBMS-NSF regional conference series in applied mathematics; 74. SIAM, Berlin, 2001.

- [5] Uriel Feige. A threshold of $\ln n$ for approximating set-cover. *Proceedings of the 28th ACM Symposium on Theory of Computing*, pages 314–318, 1996.
- [6] Jon Feldman and Matthias Ruhl. The directed steiner network problem is tractable for a constant number of terminals. In *IEEE Symposium on Foundations of Computer Science*, pages 299–308, 1999.
- [7] Martin Grötschel, László Lovász, and Alexander Schrijver. *Geometric Algorithms and Combinatorial Optimization*, volume 2 of *Algorithms and Combinatorics*. Springer, 1988.
- [8] Martin Grötschel and Clyde L. Monma. Integer polyhedra arising from certain network design problems with connectivity constraints. *SIAM Journal on Discrete Mathematics*, 3(4):502–523, 1990.
- [9] Martin Grötschel, Clyde L. Monma, and Mechthild Stoer. Computational results with a cutting plane algorithm for designing communication networks with low-connectivity constraints. *Operations Research*, 40:309–330, 1992.
- [10] Tobias Polzin. *Algorithms for the Steiner Problems in Networks*. PhD thesis, University of Saarland, 2003.
- [11] Tobias Polzin and Siavash Vahdati Daneshmand. A comparison of Steiner tree relaxations. *Discrete Applied Mathematics*, 112:241–261, 2001.
- [12] Hans Jürgen Prömel and Angelika Steger. *The Steiner Tree Problem*. Vieweg, Braunschweig/Wiesbaden, 2002.
- [13] S. Raghavan and Thomas L. Magnanti. Network connectivity. In Mauro Dell’Amico, Francesco Maffioli, and Silvano Martello, editors, *Annotated Bibliographies in Combinatorial Optimization*, pages 335–354. Wiley, Chichester, 1997.