

# A mathematical model for case hardening of steel<sup>1</sup>

Antonio Fasano<sup>2</sup>, Dietmar Hömberg<sup>3</sup>, and Lucia Panizzi<sup>4</sup>

<sup>2</sup> Università degli Studi di Firenze  
Dipartimento di Matematica “Ulisse Dini”  
Viale Morgagni 67/A, 50134 Firenze, Italy  
E-Mail: fasano@math.unifi.it

<sup>3</sup> Weierstrass Institute for Applied Analysis and Stochastics  
Mohrenstr. 39, 10117 Berlin, Germany  
E-Mail: hoemberg@wias-berlin.de

<sup>4</sup> Scuola Normale Superiore  
Piazza dei Cavalieri, 7, 56126 Pisa, Italy  
E-Mail: l.panizzi@sns.it

## Abstract

A mathematical model for the case hardening of steel is presented. Carbon is dissolved in the surface layer of a low-carbon steel part at a temperature sufficient to render the steel austenitic, followed by quenching to form a martensitic microstructure. The model consists of a nonlinear evolution equation for the temperature, coupled with a nonlinear evolution equation for the carbon concentration, both coupled with two ordinary differential equations to describe the evolution of phase fractions. We investigate questions of existence and uniqueness of a solution and finally present some numerical simulations.

**2000 Mathematics Subject Classification:** 35K60, 35R05, 82B26.

**Keywords and Phrases:** Heat treatment, phase transitions, coupled PDE, case hardening.

---

<sup>1</sup>This work has been partly supported by the DFG Research Center MATHEON “Mathematics for key technologies” in Berlin.

# 1 Introduction

The goal of case hardening is to create a workpiece surface which is resistant to external stresses and abrasion, while its case is still ductile in order to reduce fatigue effects. The process will be explained in detail in the next section. It exploits the solid-solid phase transitions occurring during thermal treatment of steel and requires a certain amount of carbon in the layer to be hardened. Accordingly, the first stage of case hardening is a carburization step during which the outer workpiece layer is enriched by carbon. The second stage is a quenching step during which a hard and wear resistant boundary layer is achieved. Sometimes, before quenching a period of slow diffusion is allowed. The goal of this paper is to derive and analyze a mathematical model capable to describe the complete process of case hardening.

Concerning case hardening there is mostly engineering literature available (see [14, 15] and the references therein). Carburization and quenching are usually considered and studied separately. There are papers concerning only the carburization (see, for example [4]) and others regarding the quenching of carburized steel (see [17], [21]). Generally, in all of the engineering papers, a lot of attention is spent to determine the process and material parameters; nevertheless the question of finding a consistent and exhaustive database for all the parameters occurring in the whole process seems to be still open. There is a vast literature, for instance, about the diffusion coefficient of carbon in iron, (see [22] and references therein), but much less for the heat transfer coefficient during quenching. Mathematical models for phase transitions in steel and in their applications to heat treatments like induction hardening, have been developed and analyzed, e.g., in [6], [9], [10], [12], [25]. The model for the phase fraction evolutions in the present paper, follows the one proposed in [9].

The main novelty of this paper is the derivation and analysis of a mathematical model for the complete case hardening process, accounting for the coupling of temperature, phase transitions and carbon diffusion. This allows to evaluate the effect of additional diffusion of carbon prior to quenching, which could affect the final result (see [23]). Thus, from application point of view, a more accurate model might lead to a more efficient process guidance and reduced energy consumption.

The paper is organized as follows: in the next section we will derive the model. In Section 3 we present notations and assumptions. In Section 4-5 we will prove existence and uniqueness of a weak solution. Section 6 is devoted to numerical simulations; then, in Section 7, we collect our final considerations and remarks.

## 2 The mathematical model

To fix ideas we first give a sketch of the gas carburizing process. Nowadays high-technology industry employs mostly low-carbon steels, with a carbon content around 0.2%. For this reason the enrichment of carbon in a superficial layer of the workpiece may be necessary to make it resistant to fatigue. The source of carbon is a carbon-rich furnace atmosphere produced from many gaseous components, through several chemical reactions (see [23] for technical details). The workpiece is kept in the furnace until the desired amount of carbon is diffused. After carburization the second stage is quenching, a rapid cooling which can

be performed by immersion in oil or water.

In the boundary layer which has been enriched by carbon, the rapid cooling leads to the growth of martensite eventually yielding the desired hard and wear resistant layer or case, which explains why this heat treatment is called case hardening.

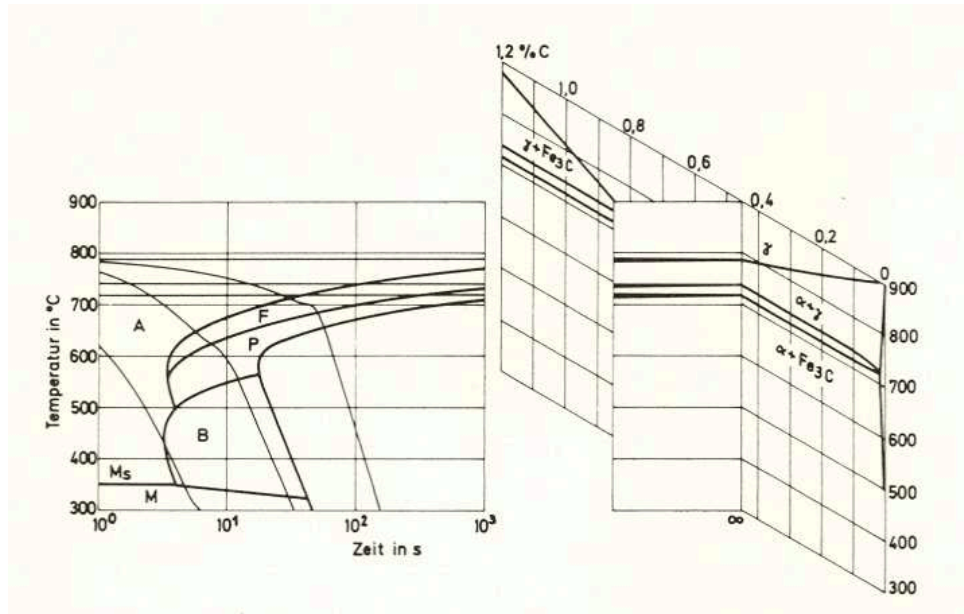

Figure 1: Equilibrium diagram of the system iron-carbon (right) as limit of the CCT-diagram with infinite low cooling rate.

The kinetics of the phase change can be briefly described as follows. Depending on temperature, two different lattice structures can occur: a body-centered-cubic (b.c.c.) and a face-centered-cubic (f.c.c) lattice. Above a certain temperature  $A_s$  steel is in the austenitic phase, a solid solution of carbon in f.c.c. iron. Below  $A_s$  this lattice is no longer stable. But before the lattice can change its configuration to form a b.c.c structure, carbon atoms have to diffuse, due to the higher solubility of carbon in the f.c.c lattice. The result is pearlite, a lamellar aggregate of ferrite and cementite, soft and ductile. Upon high cooling rate carbon has no time to diffuse and is trapped, forming a tetragonally distorted b.c.c. lattice, called martensite. Note that, depending on the cooling history and the carbon concentration, also two other phases, ferrite and bainite, can occur.

The transformation diagrams of interest for the modelling of the phase fractions evolution (see equations 2.1a,b below), during the cooling process, are called indeed *continuous cooling transformation* (CCT) diagrams and describe the transformation of austenite as a function of time for a continuously decreasing temperature. For instance, in the left-hand side of Figure 1, the CCT diagram for the steel AISI 1045 is shown. In other words a sample is austenitized and then cooled at a predetermined rate and the degree of transformation is measured, for example by dilatometry. The start of transformation is defined as the temperature at which 1% of the new microstructure has formed. The transformation is completed when only 1% of the original austenite is left.

In carburized steels the process is strongly influenced by the carbon content, which varies

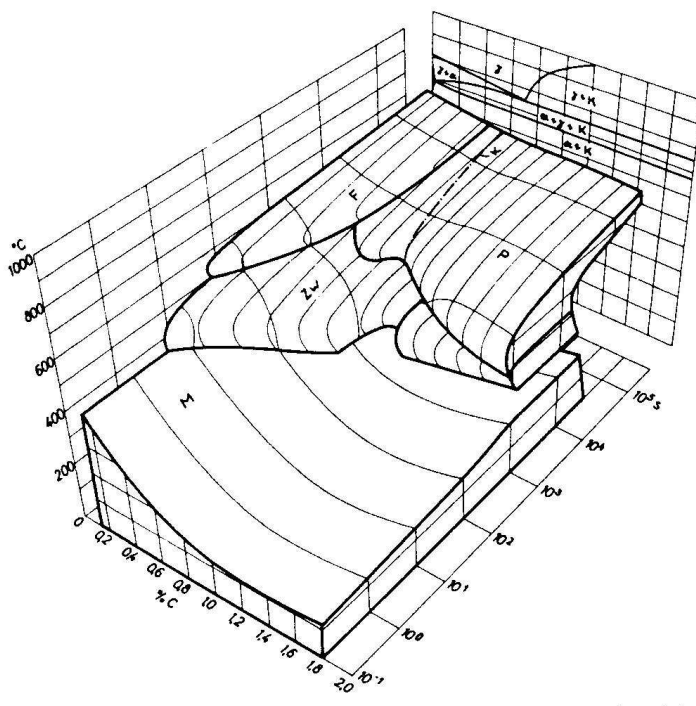

Figure 2: Three-dimensional presentation of the transformation characteristic of a 14NiCr14 steel, for continuous cooling, after austenization at  $1023^{\circ}K$  (Symbols: ZW bainite, M martensite, P pearlite, F ferrite).

from the carbon-enriched superficial layer to the core. Thus, it cannot be described by only one continuous-cooling-transformation diagram. Figure 2 shows a continuous cooling diagram describing, for a given austenitizing condition, the transformation at all carbon levels in a carburized specimen. The cross sections for fixed carbon percentages give CCT diagrams of the type of the one plotted in Figure 1 on the left. This figure also shows that, with infinitely-slow cooling, the CCT diagram is identical with the equilibrium diagram for the chemical composition of the steel. To avoid unnecessary technicalities for the modelling, we assume that the cooling takes place from the high temperature phase austenite with phase fraction  $a$  to two different product phases, pearlite with fraction  $p$  and martensite with fraction  $m$ . A more elaborate model accounting for all the phases occurring during the heat treatment of steel can be found in [12].

The evolution of the phases  $p$  and  $m$  can be described by the following system:

$$\dot{p} = (1 - p - m)g_1(\theta, c) \quad (2.1a)$$

$$\dot{m} = [\min\{\bar{m}(\theta, c); 1 - p\} - m]_+ g_2(\theta, c) \quad (2.1b)$$

$$p(0) = 0 \quad (2.1c)$$

$$m(0) = 0 \quad (2.1d)$$

where  $c$  is the concentration of carbon. Here the bracket  $[ ]_+$  denotes the positive part function  $[x]_+ = \max\{x, 0\}$  and the dot means the derivative with respect to  $t$ . While the

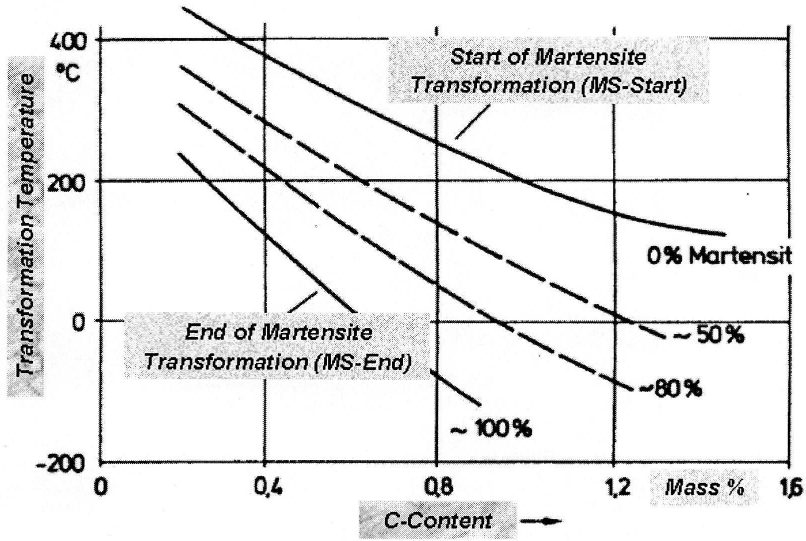

Figure 3: Level curves of function  $\bar{m}(\theta, c)$ .

growth rate of pearlite  $\dot{p}$  is assumed to be proportional to the remaining austenite fraction, the rate of martensite growth  $\dot{m}$  is zero if  $m$  exceeds either the non-perlitic fraction  $1 - p$ , or the threshold  $\bar{m}$  depending on both temperature and carbon concentration. Indeed martensite is produced at temperatures less than a value  $M_s$  but complete transformation to martensite can be obtained only below some other temperature threshold  $M_f$ . Both these temperatures depend on the local value of carbon concentration. The quantity  $\bar{m}(\theta, c)$  represents the maximum attainable value of martensite fraction and can be defined as:

$$\bar{m}(\theta, c) = \begin{cases} 0 & \theta > M_s(c) \\ 1 & \theta < M_f(c) \end{cases}$$

and by interpolation for intermediate temperatures. Since there is no phase transition from pearlite to martensite, the term  $\min\{\bar{m}(\theta, c); 1 - p\}$  represents the maximal fraction of martensite that can be reached at time  $t$ .

The functions  $g_1$  and  $g_2$  are positive given functions that can be identified from the time-temperature-transformation diagrams described before. The process of carbon diffusion is governed by the following nonlinear parabolic equation:

$$\frac{\partial c}{\partial t} - \text{div}((1 - p - m)D(\theta, c)\nabla c) = 0.$$

The factor  $(1 - p - m)$  in front of the diffusion coefficient  $D(\theta, c)$  reflects the fact that enrichment with carbon only takes place in the austenite phase. The difference in carbon potential between the surface and the workpiece provides the driving force for carbon diffusion into the piece. The carbon potential of the furnace atmosphere must be greater than the carbon potential of the surface of the workpiece for carburizing to occur. Hence we have the following boundary condition:

$$-(1 - p - m)D(\theta, c)\frac{\partial c}{\partial \nu} = \beta(c - c_p)$$

where  $\beta$ , the mass transfer coefficient, controls the rate at which carbon is absorbed by the steel during carburizing and  $c_p$  is the carbon concentration in the furnace, usually named carbon potential of the gas.  $\frac{\partial c}{\partial \nu}$  denotes the outward normal derivative. The evolution of temperature during the entire process is described by the following nonlinear problem

$$\begin{aligned}\rho\alpha(\theta)\frac{\partial\theta}{\partial t} - \operatorname{div}(k\nabla\theta) &= \rho L_p(\theta)\dot{p} + \rho L_m(\theta)\dot{m} \\ -k\frac{\partial\theta}{\partial\nu} &= h(\theta - \theta_\Gamma) \\ \theta(x, 0) &= \theta_0.\end{aligned}$$

Here  $\rho$  is the mass density,  $\alpha$  the specific heat,  $k$  the heat conductivity of the material.  $L_p$  and  $L_m$  denote latent heats of the austenite-pearlite and the austenite-martensite phase changes, respectively.  $\theta_\Gamma$  is the temperature of the coolant and  $\theta_0(x)$  is the temperature at the beginning of the process. For simplicity  $\rho$  and  $k$  are taken constant.

In the technical process, we have three different time stages:

- Stage 1: carburization in a furnace, hence  $\beta \neq 0$  and  $h = 0$ .
- Stage 2: diffusion period, with  $\beta = 0$  and  $h \neq 0$ , serving as a linearized radiation law.
- Stage 3: quenching with  $\beta = 0$  and  $h \neq 0$ .

From the mathematical point of view, without loss of generality, we will assume that  $\beta$  and  $h$  are time independent functions. Then, the mathematical result to be formulated in the following section can be applied subsequently to the three process stages, covering the complete case hardening process.

### 3 Assumptions and main result

Let  $\Omega \subset \mathbb{R}^3$  be an open bounded set with  $C^2$ -boundary  $\partial\Omega$  and  $Q_T := \Omega \times (0, T)$  the corresponding time cylinder. We use the following notations for function spaces:

- $W^{1,\infty}(0, T; L^\infty(\Omega)) = \{v \in L^\infty(0, T; L^\infty(\Omega)) : v_t \in L^\infty(0, T; L^\infty(\Omega))\}$ .
- $W_p^{r,s}(Q_T) = L^p(0, T; W_p^r(\Omega)) \cap W_p^s(0, T; L^p(\Omega))$ .  
For  $p = 2$  we write  $W_p^{r,s}(Q_T) = H^{r,s}(Q_T)$ .
- We denote by  $V$  the space  $H^1(\Omega)$  and by  $V^*$  the space  $(H^1(\Omega))^*$ .  
 $W(0, T) = \{v \in L^2(0, T; V) : v_t \in L^2(0, T; V^*)\}$ , endowed with the norm

$$\|v\|_{W(0,T)} = \left( \int_0^T (\|v(t)\|_V^2 + \|v'(t)\|_{V^*}^2) dt \right)^{\frac{1}{2}}.$$

Throughout the paper we will use the following assumptions:

(A1)  $\rho$  and  $k$  are positive constants.

(A2)  $\alpha \in C(\mathbb{R})$ .  $L_p, L_m \in L^\infty(\mathbb{R})$  and they are Lipschitz-continuous.

(A3)  $\theta_\Gamma$  is a positive constant.  $h \in L^\infty(\partial\Omega)$  with  $h(x) \geq 0$  a.e. in  $\partial\Omega$ . We assume that  $\theta_0 \in H^1(\Omega)$  and  $c_0 \in L^2(\Omega)$ .

(A4)  $g_1, g_2$  are Lipschitz-continuous in both variables, moreover there are positive constants  $\gamma_1, \gamma_2$  such that  $0 \leq g_1(\theta, c) \leq \gamma_1$ ,  $0 \leq g_2(\theta, c) \leq \gamma_2$ ,  $\forall \theta, c \in \mathbb{R}$ .

(A5)  $\bar{m}$  is Lipschitz-continuous satisfying  $\bar{m}(\theta, c) \in [0, 1]$  for every  $\theta, c \in \mathbb{R}$ .

(A6)  $D(\theta, c)$  is Lipschitz in both arguments and there are constants  $\gamma_3, \gamma_4$  such that  $0 < \gamma_3 \leq D(\theta, c) \leq \gamma_4$ ,  $\forall \theta, c \in \mathbb{R}$ .

(A7)  $c_p$  is a positive constant.  $\beta \in L^\infty(\partial\Omega)$  with  $\beta \geq 0$  a.e. in  $\partial\Omega$ .

Summarizing the model equations of Section 2, we consider the following boundary value problem:

$$\rho\alpha(\theta)\frac{\partial\theta}{\partial t} - \operatorname{div}(k\nabla\theta) = \rho L_p(\theta)p_t + \rho L_m(\theta)m_t \quad \text{in } Q_T \quad (3.1a)$$

$$\frac{\partial c}{\partial t} - \operatorname{div}((1-p-m)D(\theta, c)\nabla c) = 0 \quad \text{in } Q_T \quad (3.1b)$$

$$p_t = (1-p-m)g_1(\theta, c) \quad \text{in } Q_T \quad (3.1c)$$

$$m_t = [\min\{\bar{m}(\theta, c); 1-p\} - m]_+ g_2(\theta, c) \quad \text{in } Q_T \quad (3.1d)$$

$$-k\frac{\partial\theta}{\partial\nu} = h(\theta - \theta_\Gamma) \quad \text{on } \partial\Omega \times (0, T) \quad (3.1e)$$

$$-(1-p-m)D(\theta, c)\frac{\partial c}{\partial\nu} = \beta(c - c_p) \quad \text{on } \partial\Omega \times (0, T) \quad (3.1f)$$

$$\theta(x, 0) = \theta_0 \quad \text{in } \Omega \quad (3.1g)$$

$$c(x, 0) = c_0 \quad \text{in } \Omega \quad (3.1h)$$

$$p(0) = 0 \quad \text{in } \Omega \quad (3.1i)$$

$$m(0) = 0 \quad \text{in } \Omega. \quad (3.1j)$$

We are going to prove that, under the hypothesis above, the considered problem has a weak solution.

**Theorem 3.1** (Existence of a weak solution). *Assume (A1)-(A7), then there exists a weak solution  $(\theta, c, p, m)$  to problem (3.1a-j) such that  $\theta \in H^{2,1}(Q_T)$ ,  $c \in W(0, T)$ ,  $p, m \in W^{1,\infty}(0, T; L^\infty(\Omega))$ ,  $i = 1, 2$ .*

With slightly stronger assumptions on the data, we can also prove uniqueness.

**Theorem 3.2** (Uniqueness). *Suppose that (A1)-(A7) are satisfied. Assume moreover that  $\alpha$  is constant,  $D = D(\theta)$ ,  $h, \beta \in W_5^1(\partial\Omega)$ ,  $\theta_0, c_0 \in W_5^2(\Omega)$ . Then the solution to (3.1a-j) is unique.*

**Remark 1.** *The regularity assumptions on the boundary and initial values in the uniqueness theorem could be weakened; to avoid unnecessary technicalities we assumed  $\theta_\Gamma$  and  $c_p$  to be constants, but they could be in fact functions of space and time.*

## 4 Proof of Theorem 3.1

The proof is carried out using a nested fixed point argument. We divide the proof in three steps. The first is a preliminary lemma concerning the ODE system (3.1c,d) only, for  $\theta$  and  $c$  prescribed. The second step is the coupling of the ODE system and the temperature equation, which gives a solution  $p, m, \theta$  depending on  $c$  and the third is the further coupling with the equation for  $c$ .

We begin with considering the initial value problem

$$z_t = f(z, \theta, c) \quad \text{in } Q_T \quad (4.1a)$$

$$z(0) = 0 \quad \text{in } \Omega \quad (4.1b)$$

where  $z = (p, m)^T$  and  $f = (f_1, f_2)^T$  denotes the right-hand side of (3.1c,d).

**Lemma 4.1.** *Under the assumption (A4), (A5) the following statements are valid:*

(a) *For every  $\theta, c \in L^2(Q_T)$  problem (4.1a)-(4.1b) has a unique solution  $z$  such that  $p \geq 0, m \geq 0$  and*

$$\|z\|_{W^{1,\infty}(0,T;L^\infty(\Omega))} \leq M$$

*for a constant  $M$  independent from  $\theta$  and  $c$ . Moreover, there exists a constant  $c_T$  such that*

$$0 \leq p(x, t) + m(x, t) \leq c_T < 1 \quad \text{for a.e. } (x, t) \text{ in } Q_T.$$

(b) *There are constants  $M_1, M_2 > 0$  such that for every  $\theta_1, \theta_2, c_1, c_2 \in L^p(Q_T)$ , for almost all  $t \in (0, T)$  and all  $p \geq 2$  we have*

$$\|z_1(t) - z_2(t)\|_{W^{1,p}(\Omega)}^p \leq M_1 \int_0^t \|\theta_1 - \theta_2\|_{L^p(\Omega)}^p ds + M_2 \int_0^t \|c_1 - c_2\|_{L^p(\Omega)}^p ds \quad (4.2)$$

*where  $p_i, m_i$  is the solution corresponding to  $(\theta_i, c_i)$ , and  $|\cdot|$  is the Euclidean norm in  $\mathbb{R}^2$ .*

*Proof of Lemma 4.1.* In order to prove (a) it is convenient to rewrite problem (4.1a,b) as:

$$z_t = F(z, t) \quad \text{in } (0, T) \quad (4.3a)$$

$$z(0) = 0 \quad (4.3b)$$



with  $F(z, \cdot) = f(z, \theta(\cdot), c(\cdot))$ .

First of all we are going to show that the hypothesis of the existence theorem of Carathéodory are satisfied:

(i)

$$\begin{aligned} t \mapsto F(z, t) & \text{ is measurable on } (0, T) \text{ for each } z \in [0, 1] \times [0, 1]; \\ z \mapsto F(z, t) & \text{ is continuous on } [0, 1] \times [0, 1] \text{ for almost all } t \in (0, T). \end{aligned}$$

These conditions follow from the definition of  $F$  as a consequence of the measurability of  $\theta$  and  $c$  on  $(0, T)$  and of the fact that  $g_1(\theta, c), g_2(\theta, c)$  are Lipschitz continuous in both variables.

(ii) Using assumption (A4),(A5) we have

$$|F_i(z, t)| \leq (1 + |p| + |m|)\gamma_i \leq 3\gamma_i \quad \text{for } i = 1, 2 \quad \text{on } [0, 1] \times [0, 1] \times (0, T).$$

According to Carathéodory Theorem (cf, eg., [26], p.1044) (4.3a,b) has a solution on some time interval  $(0, T_+)$ .

Next we are going to show that the solution is unique. To this end we have to prove that

$$|F(z_1, t) - F(z_2, t)| \leq L|z_1 - z_2| \quad \forall (z_1, t), (z_2, t) \in [0, 1] \times [0, 1] \times (0, T). \quad (4.4)$$

Indeed, according to the definition of  $F$ :

$$\begin{aligned} |F(z_1, t) - F(z_2, t)|^2 &= |(1 - p_1 - m_1)g_1(t) - (1 - p_2 - m_2)g_1(t)|^2 \\ &+ |[\min\{\bar{m}(t); 1 - p_1\} - m_1]_+ g_2(t) - [\min\{\bar{m}(t); 1 - p_2\} - m_2]_+ g_2(t)|^2. \end{aligned}$$

Thanks to the boundedness of  $g_1$  and  $g_2$ , we obtain

$$|(1 - p_1 - m_1)g_1(t) - (1 - p_2 - m_2)g_1(t)| \leq \gamma_1(|p_1 - p_2| + |m_2 - m_1|)$$

and

$$\begin{aligned} &|[\min\{\bar{m}(t); 1 - p_1\} - m_1]_+ g_2(t) - [\min\{\bar{m}(t); 1 - p_2\} - m_2]_+ g_2(t)| \\ &\leq \gamma_2 |\min\{\bar{m}(t); 1 - p_1\} - m_1 - \min\{\bar{m}(t); 1 - p_2\} + m_2|. \end{aligned}$$

We shall now distinguish some cases.

If either  $\min\{\bar{m}(t); 1 - p_i\} = 1 - p_i$  or  $\min\{\bar{m}(t); 1 - p_i\} = \bar{m}(t)$ , for  $i = 1, 2$ , (4.4) immediately follows.

If  $\min\{\bar{m}(t); 1 - p_1\} = 1 - p_1$  and  $\min\{\bar{m}(t); 1 - p_2\} = \bar{m}(t)$  (the same holds for inverted indices), we have

$$\begin{aligned} &\gamma_2 |\min\{\bar{m}(t); 1 - p_1\} - m_1 - \min\{\bar{m}(t); 1 - p_2\} + m_2| \\ &\leq \gamma_2 (|m_1 - m_2| + |1 - p_1 - \bar{m}(t)|) \leq \gamma_2 (|m_1 - m_2| + |p_1 - p_2|). \quad (4.5) \end{aligned}$$

Thus, there exists a positive constant  $L$  such that

$$|F(z_1, t) - F(z_2, t)| \leq L|z_1 - z_2|.$$

Hence we have proved uniqueness of  $z$  on  $(0, T_+)$ .

Now, we define  $T_\epsilon$  as the maximal time such that the solution to (4.3a,b) exists and

$Z < 1 - \epsilon$  on  $(0, T_\epsilon)$ , where  $Z = p + m$ .

The last step in order to prove point (a) of the lemma is to show that for any  $T > 0$  there exists an  $\epsilon$  such that  $|Z| \leq 1 - \epsilon$  in  $[0, T]$ .

This will be done by means of a classical comparison criterium for ODE (see for instance [16], Chap.I, Prop. 3.1).

$Z = p + m$  satisfies, on  $[0, T_\epsilon)$ :

$$\begin{aligned}\dot{Z}(t) &= (1 - Z(t))g_1(t) + [\min\{\bar{m}(t); 1 - p(t)\} - m(t)]_+ g_2(t) \\ &\leq g(t, Z(t)) := (1 - Z(t))(g_1(t) + g_2(t)), \\ Z(0) &= 0.\end{aligned}$$

Now, if we consider on  $[0, T]$  the auxiliary problem:

$$\begin{aligned}\dot{V}(t) &= (1 - V(t))(g_1(t) + g_2(t)) = g(t, V(t)) \\ V(0) &= 0\end{aligned}$$

the solution is given by

$$V(t) = 1 - e^{-\int_0^t (g_1 + g_2)(s) ds} \quad \forall t \in [0, T]$$

and we immediately have that there exists a constant  $C_T > 0$  such that:

$$0 \leq V(t) \leq C_T < 1 \quad \text{on} \quad [0, T].$$

Notice that  $g(t, V(t)) = (1 - V(t))(g_1(t) + g_2(t))$  is Lipschitz continuous on  $[0, T)$  with respect to  $V$ .

Thus, choosing  $\epsilon = 1 - C_T$ , we have

$$Z(t) \leq V(t) \leq 1 - \epsilon \quad \text{on} \quad [0, T].$$

Since  $T_\epsilon$  was chosen maximally such that  $Z(t) \leq 1 - \epsilon$  on  $[0, T_\epsilon]$ , it follows that  $T_\epsilon \geq T$ .

(b) Let us consider again the equation  $z_t = f(z, \theta, c)$ . Let  $z_i$  be the solution to (4.1a,b), corresponding to  $\theta_i, c_i$ ,  $i = 1, 2$ . Denoting  $z = z_1 - z_2$ , subtracting the equations and taking the scalar product with the function  $|z|^{p-2}z$ , we obtain:

$$\frac{1}{p} \int_{\Omega} |z(t)|^p dx = \int_0^t \int_{\Omega} \left( f(z_1, \theta_1, c_1) - f(z_1, \theta_2, c_2) \right) \cdot z |z|^{p-2} dx ds. \quad (4.6)$$

Invoking (A4),  $f$  is Lipschitz-continuous in all variables, thus, proceeding from (4.6), the conclusion follows through standard application of Young's inequality and Gronwall lemma. The proof is thus completed. □

Next, we define

$$B(\theta, c) := \rho L_p(\theta) \dot{p} + \rho L_m(\theta) \dot{m}, \quad (4.7)$$

where  $(p, m)$  depends on  $\theta, c$  as characterized by the previous lemma.

**Lemma 4.2.** *Suppose that (A2),(A4) hold. Then the operator  $B$  defined by (4.7) has the following properties*

(a) *There exists a constant  $\bar{B}$  independent of  $\theta, c$  such that, for all  $\theta \in L^2(Q_T), c \in L^2(Q_T)$*

$$\|B(\theta, c)\|_{L^\infty(Q_T)} \leq \bar{B}.$$

(b) *Given  $c \in L^2(Q_T)$ , let  $\theta_k \subset L^2(Q_T)$  be any sequence converging strongly in  $L^2(Q_T)$  to  $\theta \in L^2(Q_T)$ . Then for every  $p \in [1, \infty)$ , we have*

$$B(\theta_k, c) \rightarrow B(\theta, c) \quad \text{strongly in } L^p(Q_T). \quad (4.8)$$

(c) *There are constants  $K_1, K_2 > 0$  such that for all  $\theta_1, \theta_2, c_1, c_2 \in L^2(\mathbb{R} \times \mathbb{R})$  and for almost all  $x \in \Omega$  and every  $t \in (0, T)$*

$$\begin{aligned} & \int_0^t |B(\theta_1(x, s), c_1(x, s)) - B(\theta_2(x, s), c_2(x, s))|^2 ds \\ & \leq K_1 \int_0^t |\theta_1(x, s) - \theta_2(x, s)|^2 ds + K_2 \int_0^t |c_1(x, s) - c_2(x, s)|^2 ds. \end{aligned}$$

*Proof of Lemma 4.2.* (a) follows directly from assumptions (A2),(A4),(A5) and Lemma 4.1 (a).

(b) We have

$$\dot{p}_{\theta, c} = (1 - p - m)g_1(\theta, c) \quad (4.9)$$

$$\dot{m}_{\theta, c} = [\min\{\bar{m}(\theta, c); 1 - p\} - m]_+ g_2(\theta, c). \quad (4.10)$$

Let  $x \in \Omega \setminus N$ , with  $N \subset \Omega$  of zero measure and consider  $z = (p, m)$ . By Lemma 4.1 (a),  $\|z_{\theta_k}\|_{W^{1,\infty}(0,T;L^\infty(\Omega))} \leq M \forall k$ , thus  $\|z_{\theta_k}\|_{W^{1,p}(0,T;L^\infty(\Omega))} \leq M \forall k, \forall p < \infty$ . Thus, there exists a subsequence,  $\{\theta_{k'}\}$ , and some  $\hat{z}$  such that

$$z_{\theta_{k'}}(x, \cdot) \rightarrow \hat{z}(x, \cdot) \quad \text{weakly - star in } W^{1,\infty}(0, T).$$

Thus, we have

$$\dot{z}_{\theta_{k'}}(x, \cdot) \rightarrow \dot{\hat{z}}(x, \cdot) \quad \text{weakly in } L^p(0, T) \quad \forall p < \infty, \quad (4.11)$$

$$z_{\theta_{k'}}(x, \cdot) \rightarrow \hat{z}(x, \cdot) \quad \text{strongly in } C[0, T]. \quad (4.12)$$

Since the solution to (4.14d,e) is unique we have  $\hat{z}(x, \cdot) = z_\theta(x, \cdot)$  and the convergence holds for the whole sequence, hence we can conclude that  $z_{\theta_k}(x, t) \rightarrow z_\theta(x, t)$  pointwise in  $Q$ . Since  $\theta_k \rightarrow \theta$  strongly in  $L^2(Q_T)$ , using assumption (A4), possibly extracting a subsequence, we have

$$\rho L_p(\theta_{k'}) \dot{p}_{\theta_{k'}, c} + \rho L_m(\theta_{k'}) \dot{m}_{\theta_{k'}, c} \rightarrow \rho L_p(\theta) \dot{p}_\theta + \rho L_m(\theta) \dot{m}_\theta \quad \text{a.e in } Q_T. \quad (4.13)$$

But, applying Lebesgue theorem, we get

$$B(\theta_{k'}, c) \rightarrow B(\theta, c) \quad \text{strongly in } L^p(Q_T).$$

Since the limit does not depend on the extracted subsequence the convergence holds for the whole sequence  $\{\theta_k\}$ , hence we obtain (4.8).

(c) follows directly from assumption (A2) and Lemma 4.1 (b).  $\square$

**Lemma 4.3.** *Let  $\hat{c} \in L^2(0, T; L^2(\Omega))$ . There exists a unique  $\theta(\hat{c}) \in H^{2,1}(Q_T)$  and a unique  $z(\hat{c}) = (p(\hat{c}), m(\hat{c})) \in W^{1,\infty}(0, T; L^\infty(\Omega)) \times W^{1,\infty}(0, T; L^\infty(\Omega))$ , satisfying*

$$\rho\alpha(\theta) \frac{\partial\theta}{\partial t} - \operatorname{div}(k\nabla\theta) = B(\theta, \hat{c}) \quad \text{in } Q_T \quad (4.14a)$$

$$-k \frac{\partial\theta}{\partial\nu} = h(\theta - \theta_\Gamma) \quad \text{on } \partial\Omega \times (0, T) \quad (4.14b)$$

$$\theta(x, 0) = \theta_0 \quad \text{in } \Omega \quad (4.14c)$$

$$z_t = f(z, \theta, \hat{c}) \quad \text{in } Q_T \quad (4.14d)$$

$$z(0) = 0 \quad \text{in } \Omega. \quad (4.14e)$$

where  $f$  is defined as in (4.1a). Moreover, there exist  $\lambda_1, \lambda_2 > 0$  such that

$$\|\theta_1 - \theta_2\|_{L^2(0,t;L^2(\Omega))}^2 \leq \lambda_1 \int_0^t \|\hat{c}_1 - \hat{c}_2\|_{L^2(0,s;L^2(\Omega))}^2 ds \quad (4.15)$$

and

$$\|z_1 - z_2\|_{L^2(0,t;L^2(\Omega))}^2 \leq \lambda_2 \int_0^t \|\hat{c}_1 - \hat{c}_2\|_{L^2(0,s;L^2(\Omega))}^2 ds, \quad (4.16)$$

where  $(\theta_i, c_i)$  is the solution corresponding to  $\hat{c}_i$ ,  $i = 1, 2$ .

*Proof of Lemma 4.3.* Existence. We introduce the operator

$$P : L^2(Q_T) \rightarrow L^2(Q_T),$$

$$\theta = P\hat{\theta},$$

by demanding  $\theta$  to be the solution of the linear parabolic problem

$$\rho\alpha(\hat{\theta}) \frac{\partial\theta}{\partial t} - k\Delta\theta = B(\hat{\theta}, \hat{c}) \quad \text{in } Q_T \quad (4.17a)$$

$$-k \frac{\partial\theta}{\partial\nu} = h(\theta - \theta_\Gamma) \quad \text{on } \partial\Omega \times (0, T) \quad (4.17b)$$

$$\theta(x, 0) = \theta_0 \quad \text{in } \Omega. \quad (4.17c)$$

According to classical results about parabolic equations, problem (4.17a-c) has a unique strong solution  $\theta \in H^{2,1}(Q_T)$  (see, for instance, [18]), therefore the operator  $P$  is well-defined.

Moreover, thanks to Lemma 4.2 (a), there exists a constant  $M > 0$ , independent of  $\hat{\theta}$ , such that:

$$\|\theta\|_{H^{2,1}(Q_T)} \leq M. \quad (4.18)$$

We shall now show the continuity of the operator  $P$ .

Let  $\hat{\theta}_n \subset L^2(Q_T)$  with  $\hat{\theta}_n \rightarrow \hat{\theta}$  strongly in  $L^2(Q_T)$ . Defining  $\theta_n = P\hat{\theta}_n$ , in view of (4.18),  $\|\theta_n\|_{H^{2,1}(Q_T)} \leq M$ . Thus, we can find a sub-sequence  $\hat{\theta}_{n'}$  such that

$$\theta_{n'} \rightarrow \theta \quad \text{weakly in } H^{2,1}(Q_T), \quad \text{strongly in } L^2(Q_T), \quad (4.19a)$$

$$\theta_{n'} \rightarrow \theta \quad \text{a.e. in } Q_T. \quad (4.19b)$$

Testing (4.17a) by  $\phi \in L^2(0, t; H^1(\Omega))$ , we get

$$\begin{aligned} \int_0^t \int_{\Omega} \rho \alpha(\hat{\theta}_{n'}) \theta_{n',s} \phi \, dx \, ds + k \int_0^t \int_{\Omega} \nabla \theta_{n'} \nabla \phi \, dx \, ds \\ + \int_0^t \int_{\partial\Omega} h(\sigma) (\theta_{n'} - \theta_{\Gamma}) \phi \, d\sigma \, ds - \int_0^t \int_{\Omega} B(\hat{\theta}_{n'}, \hat{c}) \phi \, dx \, ds = 0. \end{aligned} \quad (4.20)$$

By means of (4.19a,b) we can pass to the limit in last three terms of (4.20). We can break the first term in two terms

$$\rho \int_0^t \int_{\Omega} \alpha(\hat{\theta}_{n'}) \theta_{n',s} \phi \, dx \, ds = \rho \int_0^t \int_{\Omega} \alpha(\hat{\theta}_{n'}) (\theta_{n',s} - \theta_s) \phi \, dx \, ds + \rho \int_0^t \int_{\Omega} \alpha(\hat{\theta}_{n'}) \theta_s \phi \, dx \, ds.$$

Thanks to the continuity of  $\alpha$ , we have that

$$\alpha(\hat{\theta}_{n'}) \phi \rightarrow \alpha(\hat{\theta}) \phi \quad \text{a.e. in } Q_T$$

thus, using Lebesgue theorem,  $\rho \alpha(\hat{\theta}_{n'}) \phi \rightarrow \rho \alpha(\hat{\theta}) \phi$  strongly in  $L^2(Q_T)$  while  $\theta_{n',s} \rightarrow \theta_s$  weakly in  $L^2(Q_T)$ . Thus,  $\int_0^t \int_{\Omega} \alpha(\hat{\theta}_{n'}) (\theta_{n',s} - \theta_s) \phi \, dx \, ds \rightarrow 0$  and

$$\rho \int_0^t \int_{\Omega} \alpha(\hat{\theta}_{n'}) \theta_{n',s} \phi \, dx \, ds \rightarrow \rho \int_0^t \int_{\Omega} \alpha(\hat{\theta}) \theta_s \phi \, dx \, ds.$$

Hence we have obtained

$$\begin{aligned} \rho \int_0^t \int_{\Omega} \alpha(\hat{\theta}) \theta_s \phi \, dx \, ds + k \int_0^t \int_{\Omega} \nabla \theta \nabla \phi \, dx \, ds \\ + \int_0^t \int_{\partial\Omega} h(\sigma) (\theta - \theta_{\Gamma}) \phi \, d\sigma \, ds - \int_0^t \int_{\Omega} B(\hat{\theta}, \hat{c}) \phi \, dx \, ds = 0. \end{aligned}$$

As the solution to the parabolic problem (4.17a-c) is unique, we have

$$\theta = P\hat{\theta} \quad \text{a.e. in } Q_T$$

and, since the limit does not depend on the extracted sub-sequence, it follows that

$$P\hat{\theta}_n \rightarrow P\hat{\theta}$$

weakly in  $H^{2,1}(Q_T)$  and strongly in  $L^2(Q_T)$ .

Now, let

$$K := \{u \in L^2(Q_T) : \|u\|_{H^{2,1}(Q_T)} \leq M\}.$$

$K$  is non-empty, convex, closed and relatively compact subset of  $L^2(Q_T)$  and  $F : K \subset L^2(Q_T) \rightarrow K$  is a continuous mapping. By Schauder fixed point theorem, there exists a fixed point of the mapping  $F$ , i.e. there exists a weak solution  $\theta \in H^{2,1}(Q_T)$  to (3.1a,e,f).

Uniqueness and stability. Let

$$J(\theta) := \int_0^\theta \rho \alpha(\xi) d\xi. \quad (4.21)$$

Integration of (3.1a) with respect to time leads to

$$\int_0^t B(\theta, c)(x, s) ds = J(\theta(x, t)) - J(\theta_0(x)) - k\Delta \int_0^t \theta(x, s) ds. \quad (4.22)$$

Now, let  $\theta_1, \theta_2 \in H^{2,1}(Q_T)$  be solutions to (3.1a,e,g) corresponding to  $\hat{c}_1, \hat{c}_2$  respectively. Inserting these solutions into (4.22), subtracting both equations, and testing by  $\theta := \theta_1 - \theta_2$ , we find

$$\begin{aligned} & \int_0^t \int_\Omega \left( \int_0^s B(\theta_1(x, \xi), \hat{c}_1(x, \xi)) - B(\theta_2(x, \xi), \hat{c}_2(x, \xi)) d\xi \right) \theta(x, s) dx ds \\ &= \int_0^t \int_\Omega [J(\theta_1(x, s)) - J(\theta_2(x, s))] \theta(x, s) dx ds + k \int_0^t \int_\Omega \nabla \left( \int_0^s \theta(x, \xi) d\xi \right) \nabla \theta(x, s) dx ds \\ & \quad + \int_0^t \int_{\partial\Omega} \left( \int_0^s h(\sigma) \theta(\sigma, \xi) d\xi \right) \theta(\sigma, s) d\sigma ds. \end{aligned} \quad (4.23)$$

Concerning the last term we can see that

$$\begin{aligned} & \int_0^t \int_{\partial\Omega} \left( \int_0^s h(\sigma) \theta(\sigma, \xi) d\xi \right) \theta(\sigma, s) d\sigma ds = \int_0^t \int_{\partial\Omega} h(\sigma) \left( \int_0^s \theta(\sigma, \xi) d\xi \right) \theta(\sigma, s) d\sigma ds \\ &= \frac{1}{2} \int_0^t \int_{\partial\Omega} h(\sigma) \frac{d}{ds} \left( \int_0^s \theta(\sigma, \xi) d\xi \right)^2 d\sigma ds = \frac{1}{2} \int_{\partial\Omega} h(\sigma) \left( \int_0^t \theta(\sigma, s) ds \right)^2 d\sigma. \end{aligned}$$

Thus, from (4.23) we get:

$$\begin{aligned} & \int_0^t \int_\Omega \left( \int_0^s B(\theta_1(x, \xi), \hat{c}_1(x, \xi)) - B(\theta_2(x, \xi), \hat{c}_2(x, \xi))(x, \xi) d\xi \right) \theta(x, s) dx ds \\ & \geq \eta\rho \int_0^t \int_\Omega \theta^2(x, s) dx ds + \frac{k}{2} \int_\Omega \left| \nabla \int_0^t \theta(x, s) ds \right|^2 dx \\ & \quad + \frac{1}{2} \int_{\partial\Omega} h(\sigma) \left( \int_0^t \theta(\sigma, s) ds \right)^2 d\sigma \geq \eta\rho \int_0^t \int_\Omega \theta^2(x, s) dx ds. \end{aligned}$$

Using Holder's and Young's inequalities and Lemma 4.1 (c) it follows that

$$\begin{aligned}
& \left| \int_0^t \int_{\Omega} \left( \int_0^s B(\theta_1(x, \xi), \hat{c}_1(x, \xi)) - B(\theta_2(x, \xi), \hat{c}_2(x, \xi)) d\xi \right) \theta(x, s) dx ds \right| \\
& \leq \frac{1}{4\delta} \int_0^t \int_{\Omega} \left( \int_0^s B(\theta_1(x, \xi), \hat{c}_1(x, \xi)) - B(\theta_2(x, \xi), \hat{c}_2(x, \xi)) d\xi \right)^2 dx ds \\
& \quad + \delta \int_0^t \|\theta(x, s)\|_{L^2(\Omega)}^2 ds \\
& \leq \frac{T}{4\delta} \int_0^t \int_{\Omega} \int_0^s \left( K_1 |\theta_1(x, \xi) - \theta_2(x, \xi)|^2 + K_2 |\hat{c}_1(x, \xi) - \hat{c}_2(x, \xi)|^2 \right) d\xi dx ds \\
& \quad + \delta \int_0^t \|\theta(x, s)\|_{L^2(\Omega)}^2 ds \\
& \leq \frac{CT}{4\delta} \int_0^t \|\theta\|_{L^2(0,s;L^2(\Omega))}^2 ds + \frac{CT}{4\delta} \int_0^t \|c\|_{L^2(0,s;L^2(\Omega))}^2 ds + \delta \int_0^t \|\theta(x, s)\|_{L^2(\Omega)}^2 ds.
\end{aligned}$$

Thus, we have

$$\begin{aligned}
\eta\rho \int_0^t \int_{\Omega} \theta^2(x, s) dx ds & \leq \frac{CT}{4\delta} \int_0^t \|\theta\|_{L^2(0,s;L^2(\Omega))}^2 ds \\
& \quad + \frac{CT}{4\delta} \int_0^t \|c\|_{L^2(0,s;L^2(\Omega))}^2 ds + \delta \int_0^t \|\theta(x, s)\|_{L^2(\Omega)}^2 ds.
\end{aligned}$$

Choosing  $\delta > 0$  such that  $\eta\rho - \delta > 0$  we have:

$$\|\theta\|_{L^2(0,t;L^2(\Omega))}^2 \leq \alpha \int_0^t \|\theta\|_{L^2(0,s;L^2(\Omega))}^2 ds + \beta \int_0^t \|c\|_{L^2(0,s;L^2(\Omega))}^2 ds$$

with constants  $\alpha, \beta > 0$ .

Hence, applying Gronwall lemma, we find a constant  $C_1$  such that

$$\|\theta_1 - \theta_2\|_{L^2(0,t;L^2(\Omega))}^2 \leq C_1 \int_0^t \|\hat{c}_1(s) - \hat{c}_2(s)\|_{L^2(0,s;L^2(\Omega))}^2 ds. \quad (4.24)$$

Inequality (4.16) follows immediately from Lemma 4.1 (b) and estimate (4.15). The proof of Lemma 4.3 is thus completed.  $\square$

Now, we are in a position to proof Theorem 3.1.

Let us denote

$$\mu(\theta, c) := (1 - p - m)D(\theta, c).$$

We note that, in view of (A6) and Lemma 4.1 (b),  $\mu$  is Lipschitz-continuous with respect to  $\theta$  and  $c$ .

We define an operator

$$\mathcal{T} : L^2(Q_T) \longrightarrow L^2(Q_T),$$

$$\mathcal{T}\hat{c} = c, \tag{4.25}$$

by demanding  $c$  to be the solution of the parabolic problem

$$\frac{\partial c}{\partial t} - \operatorname{div}(\mu_{\hat{c}} \nabla c) = 0 \quad \text{in } Q_T \tag{4.26a}$$

$$-\mu_{\hat{c}} \frac{\partial c}{\partial \nu} = \beta(c - c_p) \quad \text{on } \partial\Omega \times (0, T) \tag{4.26b}$$

$$c(x, 0) = c_0 \quad \text{in } \Omega. \tag{4.26c}$$

where  $\mu_{\hat{c}} = (1 - p_{\hat{c}} - m_{\hat{c}})D(\theta_{\hat{c}}, c)$ ,  $(\theta_{\hat{c}}, p_{\hat{c}}, m_{\hat{c}})$  being the solution to (3.1a,c,d) with respect to given  $\hat{c}$ . Denoting

$$a(c, \phi; t) := \int_{\Omega} \mu_{\hat{c}} \nabla c \nabla \phi \, dx + \int_{\partial\Omega} \beta c \phi \, d\sigma,$$

$$\langle f(t), \phi \rangle := \int_{\partial\Omega} \beta c_p \phi \, d\sigma, \quad \phi \in H^1(\Omega)$$

we have that problem (4.26a-c) is equivalent to the following one. We seek a function  $c$  such that, for all  $\phi \in H^1(\Omega)$  and a.e in  $t \in (0, T)$

$$\left\langle \frac{d}{dt} c(t), \phi \right\rangle + a(c(t), \phi; t) = \langle f(t), \phi \rangle, \tag{4.27a}$$

$$c(0) = c_0, \tag{4.27b}$$

$$c \in W(0, T), \tag{4.27c}$$

where  $\langle \cdot, \cdot \rangle$  denotes the duality between  $H^1(\Omega)$  and  $(H^1(\Omega))^*$ .

In view of (A3),(A6),(A7), (4.27a-c) admits a unique solution  $c$  (cf [26], Prop. 30.10). Moreover, there exists a constant  $M$  independent of  $\hat{c}$ , such that:

$$\|c\|_{W(0,T)} \leq M. \tag{4.28}$$

To derive the continuity of the operator  $\mathcal{T}$ , let  $\{\hat{c}_n\} \subset L^2(0, T; L^2(\Omega))$ , with  $\hat{c}_n \rightarrow \hat{c}$  strongly in  $L^2(Q_T)$ . Defining  $c_n = \mathcal{T}\hat{c}_n$ , thanks to (4.28), we have  $\|c_n\|_{W(0,T)} \leq M$ . Thus, there exists a sub-sequence  $\{\hat{c}_{n'}\}$  such that

$$c_{n'} \longrightarrow c \quad \text{weakly in } W(0, T). \tag{4.29}$$



We test (4.26a) by

$$\Phi(x, t) = \psi(t)\phi(x) \quad \text{with} \quad \psi \in C^1(0, T), \quad \psi(T) = 0, \quad \phi \in H^1(\Omega). \quad (4.30)$$

Denoting  $\mathcal{T}\hat{c}_{n'} := c_{n'}$ , we have

$$\int_0^T \int_{\Omega} c_{n',s} \Phi \, dx \, ds + \int_0^T \int_{\Omega} \mu_{\hat{c}_{n'}} \nabla c_{n'} \nabla \Phi \, dx \, ds + \int_0^T \int_{\partial\Omega} \beta(c_{n'} - c_p) \Phi \, d\sigma \, ds = 0. \quad (4.31)$$

Concerning the first term in (4.31) we have

$$\int_0^T \int_{\Omega} c_{n',s} \Phi \, dx \, ds = - \int_{\Omega} c_{n'}(x, 0) \Phi(x, 0) \, dx - \int_0^T \int_{\Omega} c_{n'} \Phi_s \, dx \, ds.$$

Now,

$$\int_{\Omega} c_{n'}(x, 0) \Phi(x, 0) \, dx = \int_{\Omega} c_0 \Phi(x, 0) \, dx,$$

and, by virtue of (4.29),

$$\int_0^T \int_{\Omega} c_{n'} \Phi_s \, dx \, ds \rightarrow \int_0^T \int_{\Omega} c \Phi_s \, dx \, ds \quad \text{a.e. in } Q_T.$$

The second term can be rearranged as

$$\int_0^T \int_{\Omega} \mu_{\hat{c}_{n'}} \nabla c_{n'} \nabla \Phi \, dx \, ds = \int_0^T \int_{\Omega} \mu_{\hat{c}_{n'}} (\nabla c_{n'} - \nabla c) \nabla \Phi \, dx \, ds + \int_0^T \int_{\Omega} \mu_{\hat{c}_{n'}} \nabla c \nabla \Phi \, dx \, ds.$$

Since  $\mu$  is continuous and bounded as a function of  $c$ , possibly extracting a subsequence, we obtain:  $\mu_{\hat{c}_{n'}}(x, t) \rightarrow \mu_{\hat{c}}(x, t)$  a.e in  $Q_T$ , thus, using Lebesgue theorem, it converges strongly in  $L^2(Q_T)$ . Thus, we have

$$\mu_{\hat{c}_{n'}} \nabla \Phi \rightarrow \mu_{\hat{c}} \nabla \Phi \quad \text{strongly in } L^2(Q_T).$$

Moreover,  $(\nabla c_{n'} - \nabla c) \rightarrow 0$  weakly in  $L^2(Q_T)$  because of (4.29), thus we obtain

$$\int_0^T \int_{\Omega} \mu_{\hat{c}_{n'}} \nabla c_{n'} \nabla \Phi \, dx \, ds \rightarrow \int_0^T \int_{\Omega} \mu_{\hat{c}} \nabla c \nabla \Phi \, dx \, ds.$$

Applying the trace theorem, the last term in (4.31) converges too.

Thus, we can pass to the limit in (4.31) obtaining

$$\begin{aligned} & -\psi(0) \int_{\Omega} c_0 \phi(x) \, dx - \int_0^T \int_{\Omega} c \psi_s \phi \, dx \, ds \\ & + \int_0^T \psi \int_{\Omega} \mu_{\hat{c}} \nabla c \nabla \phi \, dx \, ds + \int_0^T \psi \int_{\partial\Omega} \beta(c - c_p) \phi \, d\sigma \, ds = 0. \end{aligned} \quad (4.32)$$

Consequently

$$\int_0^T \psi \left( \int_{\Omega} c_s \phi \, dx + \int_0^T \int_{\Omega} \mu_{\hat{c}} \nabla c \nabla \phi \, dx + \int_0^T \int_{\partial\Omega} \beta(c - c_p) \phi \, d\sigma \right) ds = 0.$$

The above is true for  $\phi, \psi$  satisfying (4.32). Therefore (4.32) gives, a.e in  $t \in (0, T)$

$$\left\langle \frac{d}{dt} c(t), \phi \right\rangle + a(t; c(t), \phi) = \langle F(t), \phi \rangle \quad \forall \phi \in H^1(\Omega).$$

Since the solution of (4.26a-c) is unique, we can conclude

$$\mathcal{T}\hat{c} = c,$$

and, since the limit does not depend on the extracted sub-sequence, it follows that

$$\mathcal{T}\hat{c}_n \rightarrow \mathcal{T}c \tag{4.33}$$

weakly in  $W(0, T)$  and strongly in  $L^2(Q_T)$ .

Now, let

$$K := \{v \in L^2(Q_T) : \|v\|_{W(0,T)} \leq M\}.$$

$K$  is convex and compact in  $L^2(Q_T)$  and  $F : K \subset L^2(Q_T) \rightarrow K$  is a continuous mapping. By the Schauder fixed point theorem the proof is concluded.

□

## 5 Proof of Theorem 3.2

We commence with the following regularity result:

**Lemma 5.1.** *Under the assumptions of Theorem 3.2, the solutions  $\theta, c$  to the initial-boundary value problems related to equations (3.1a,b) are in  $W_5^{2,1}(Q_T)$ .*

*Proof.* Since we proved the existence of at least one solution for the initial-boundary value problems related to equations (3.1a), (3.1b), we can now follow the approach developed by J.A. Griepentrog, in the papers [7], [8] about linear parabolic equations with nonsmooth bounded coefficients, in order to improve the regularity of the solutions under consideration.

The coefficients and the right-hand sides of the equations are indeed functions in  $L^\infty(Q_T)$  and the coefficients in the boundary conditions too.

Moreover, in fact, the initial conditions are Lipschitz-continuous functions and we can apply Th.3.4 and Th.6.8 of [7] and Th.6.1 of [8], whence we obtain that  $\theta$  and  $c$  are in  $C(\bar{Q}_T)$ .

It follows that the right-hand sides of the ODEs (3.1c,d) are continuous functions, therefore the corresponding solutions are continuously differentiable.

Thus, the PDEs (3.1a,b) have continuous coefficients and we can apply a classical result of Ladyzenskaja ([18], Th.9.1, page 341) which yields:  $\theta, c \in W_5^{2,1}(Q_T)$ . □

**Lemma 5.2.** *Assuming that  $\alpha$  is constant, we have that, for every  $c_1, c_2 \in L^2(Q_T)$ , there exists a constant  $M > 0$  such that, for the corresponding  $\theta_1, \theta_2$ , it holds:*

$$\|\theta_1 - \theta_2\|_{H^{2,1}(Q_T)}^2 \leq M \|c_1 - c_2\|_{L^2(Q_T)}^2. \quad (5.1)$$

*Proof.* We consider the heat equation of our system:

$$\rho\alpha\theta_t = k\Delta\theta + \rho L_p p_t + \rho L_m m_t. \quad (5.2)$$

We write (5.2) for  $\theta_1, c_1, p_1, m_1$  and  $\theta_2, c_2, p_2, m_2$ . Subtracting, we see that the difference satisfies the following system:

$$\begin{aligned} \rho\alpha\theta_t - k\Delta\theta &= \rho(L_p(\theta_1)p_{1,t} - L_p(\theta_2)p_{2,t}) + \rho(L_m(\theta_1)m_{1,t} - L_m(\theta_2)m_{2,t}) \\ -k\partial\theta\partial\nu &= h\theta \\ \theta(x, 0) &= 0. \end{aligned}$$

Applying again standard parabolic theory (cf. [18], Th.6.1), invoking Lemma 4.2 (b) and (A2), (A3) we finish the proof.  $\square$

**Lemma 5.3.** *Let  $u \in L^\infty(0, T; L^2(\Omega)) \cap L^2(0, T; H^1(\Omega))$ , then there holds*

$$\int_0^T \|u(t)\|_{L^{10/3}(\Omega)}^{10/3} dt \leq \left( \int_0^T \|u(t)\|_{L^6(\Omega)}^2 dt \right) \|u\|_{L^\infty(0, T; L^2(\Omega))}^{4/3}.$$

*Proof.* Owing to Riesz' convexity theorem (cf. [26], A113), we have

$$\|u\|_{L^r(\Omega)} \leq \|u\|_{L^{q_1}(\Omega)}^{1-\Theta} \|u\|_{L^{q_2}(\Omega)}^\Theta,$$

for all  $u \in L^{q_1}(\Omega) \cap L^{q_2}(\Omega)$  with  $1 \leq q_1, q_2 < \infty$ ,  $0 < \Theta < 1$ , and  $\frac{1}{r} = \frac{1-\Theta}{q_1} + \frac{\Theta}{q_2}$ . Invoking the continuous embedding  $H^1(\Omega) \subset L^6(\Omega)$ , the assertion follows by defining  $q_1 = 6$ ,  $q_2 = 2$ ,  $\Theta = \frac{2}{5}$ , and  $r = \frac{10}{3}$ .  $\square$

We are now in position to prove Theorem 3.2. We write equation (3.1b) for  $c_1$  and  $c_2$ , subtract, integrate over  $Q_T$  and test by  $c_1 - c_2$ . In the sequel we will use the following notations:  $c = c_1 - c_2$ ,  $\theta = \theta_1 - \theta_2$ ,  $p = p_1 - p_2$ ,  $m = m_1 - m_2$ .

We have

$$\begin{aligned} \frac{1}{2} \int_{\Omega} c^2(t) dx + \int_0^t \int_{\Omega} \left( (1 - p_1 - m_1) D(\theta_1) \nabla c_1 - (1 - p_2 - m_2) D(\theta_2) \nabla c_2 \right) \nabla c \, dx ds \\ + \int_0^t \int_{\partial\Omega} \beta c^2 \, d\sigma ds = 0. \end{aligned}$$

Now,

$$\begin{aligned}
& \int_0^t \int_{\Omega} \left( (1 - p_1 - m_1)D(\theta_1)\nabla c_1 - (1 - p_2 - m_2)D(\theta_2)\nabla c_2 \right) \nabla c \, dx ds \\
&= \int_0^t \int_{\Omega} (1 - p_1 - m_1)D(\theta_1)|\nabla c|^2 \, dx ds - \int_0^t \int_{\Omega} (p + m)D(\theta_1)\nabla c_2 \nabla c \, dx ds \\
&+ \int_0^t \int_{\Omega} (1 - p_2 - m_2)(D(\theta_1) - D(\theta_2))\nabla c_2 \nabla c \, dx ds. \tag{5.3}
\end{aligned}$$

Thus, we have

$$\begin{aligned}
& \frac{1}{2} \int_{\Omega} c^2(t) \, dx + K_5 \int_0^t \|\nabla c\|_{L^2(\Omega)}^2 \, dx ds \\
&\leq \int_0^t \int_{\Omega} |p + m| |D(\theta_1)| |\nabla c_2| |\nabla c| \, dx ds \\
&+ \int_0^t \int_{\Omega} |1 - p_2 - m_2| |D(\theta_1) - D(\theta_2)| |\nabla c_2| |\nabla c| \, dx ds. \tag{5.4}
\end{aligned}$$

By means of Lemma 5.1, we know that  $c_2 \in W_5^{2,1}(Q_T)$ . According to Amann (cf [2], Theorem 1.1), we have the embedding  $W_5^{2,1}(Q_T) \hookrightarrow C([0, T]; W_5^1(\Omega))$ . Thus, we can estimate the second term in the right hand-side of (5.3) as:

$$\begin{aligned}
& \int_0^t \int_{\Omega} |p + m| |D(\theta_1)| |\nabla c_2| |\nabla c| \, dx ds \\
&\leq \int_0^t \|p + m\|_{L^{10/3}(\Omega)} \|\nabla c_2\|_{L^5(\Omega)} \|D(\theta_1)\|_{L^\infty(\Omega)} \|\nabla c\|_{L^2(\Omega)} \, ds \\
&\leq \delta \int_0^t \|\nabla c\|_{L^2(\Omega)}^2 \, ds + \frac{K_1}{4\delta} \int_0^t \|p + m\|_{L^{10/3}(\Omega)}^2 \, ds. \tag{5.5}
\end{aligned}$$

Thanks to Lemma 4.1 (b), we get:

$$\begin{aligned}
& \int_0^t \|p + m\|_{L^{10/3}(\Omega)}^2 \, ds = \int_0^t \left[ \int_{\Omega} |p + m|^{10/3} \, dx \right]^{3/5} \, ds \\
&\leq K_1 \int_0^t \left[ \int_0^s \int_{\Omega} \theta^{10/3} \, dx d\tau \right]^{3/5} \, ds + K_2 \int_0^t \left[ \int_0^s \int_{\Omega} c^{10/3} \, dx d\tau \right]^{3/5} \, ds. \tag{5.6}
\end{aligned}$$

Now, we apply Lemma 5.3 and Young's inequality to the right-hand side of (5.6), obtaining:

$$\begin{aligned} \int_0^t \left[ \int_0^s \int_{\Omega} \theta^{10/3} dx d\tau \right]^{3/5} ds &\leq K \int_0^t \left[ \int_0^s \|\theta\|_{H^1(\Omega)}^2 d\tau \right]^{3/5} \|\theta\|_{L^\infty(0,s;L^2(\Omega))}^{4/5} ds \\ &\leq \frac{2}{5} \delta_2 \int_0^t \int_0^s \|\theta\|_{H^1(\Omega)}^2 d\tau ds + \frac{3}{5\delta_2} \int_0^t \|\theta\|_{L^\infty(0,s;L^2(\Omega))}^2 ds. \end{aligned} \quad (5.7)$$

An analogous estimate holds for the term  $\int_0^t \left[ \int_0^s \int_{\Omega} c^{10/3} dx d\tau \right]^{3/5} ds$ .

Regarding the third term in the right-hand side of (5.3), we have:

$$\begin{aligned} \int_0^t \int_{\Omega} |1 - p_2 - m_2| |D(\theta_1) - D(\theta_2)| |\nabla c_2| |\nabla c| dx ds &\leq K_3 \int_0^t \|\theta\|_{L^6(\Omega)} \|\nabla c\|_{L^2(\Omega)} ds \\ &\leq \delta_3 \int_0^t \|\theta\|_{H^1(\Omega)}^2 ds + \frac{K_4}{4\delta_3} \int_0^t \|\nabla c\|_{L^2(\Omega)}^2 ds. \end{aligned} \quad (5.8)$$

Summing up, from (5.3) combined with (5.7) and (5.8), we find that

$$\begin{aligned} \frac{1}{2} \int_{\Omega} c^2(t) dx + K_5 \int_0^t \int_{\Omega} \|\nabla c\|^2 dx ds \\ \leq K_6 \int_0^t \|\theta\|_{H^1(\Omega)}^2 ds + K_7 \int_0^t \|\theta\|_{L^\infty(0,s;L^2(\Omega))}^2 ds + \frac{K_4}{4\delta_3} \int_0^t \|\nabla c\|_{L^2(\Omega)}^2 ds. \end{aligned} \quad (5.9)$$

Thus, by means of Lemma 5.2, for an appropriate choice of  $\delta_3$ , we end up with:

$$\frac{1}{2} \int_{\Omega} c^2(t) dx + \int_0^t \|\nabla c\|_{L^2(\Omega)}^2 dx ds \leq K_8 \int_0^t \|c\|_{L^2(\Omega)}^2 ds. \quad (5.10)$$

The proof is concluded applying Gronwall Lemma.  $\square$

The following table contains the parameters involved in the complete process.

	Value	Unit		Value	Unit
$\rho$	7800	kg/m <sup>3</sup>	$\theta_0$	1150	K
$\alpha$	385	J/Kg K	$c_0$	0.25	weight %
$L_p$	77000	J/Kg	$c_p$	1.2	weight %
$L_m$	82000	J/Kg	$\theta_\Gamma$	300	K
$\beta$ (if $t \leq T_1$ )	6e-5	m/s	$\beta$ (if $T_1 < t \leq T$ )	0	m/s
$h$ (if $t \leq T_1$ )	0	W/m <sup>2</sup> K	$h$ (if $T_1 < t \leq T$ )	10000	W/m <sup>2</sup> K
$D$	$0.47 \exp(-1.6c - (37000 - 6600c)/(1.987T))1e - 4$				m <sup>2</sup> /s
$k$	35	W/mK			

Table 1: Process parameters.

## 6 Numerical results

In this section we present some numerical simulations to demonstrate the effect of gas carburizing on a sample workpiece. The simulations are based on our model (3.1a-j). As a sample configuration, we consider the cross section of a cylinder of radius 50mm. Note that our initial temperature is chosen above the austenitization temperature such that we may assume it to be homogeneously austenitic. Material parameters are taken from the data tables for the low-carbon steel AISI 4130. The interval time  $(0, T)$  of the whole process is divided as  $(0, T_c] \cup [T_c, T)$ , where  $T_c$  denotes the ending time of carburization. For the process parameters we refer to Table 1. The expression for  $D(\theta, c)$  is taken from [23], the value of  $h$  is taken from [14]. For the function  $g_1$  we took the data of [5], cf. Fig. 4.

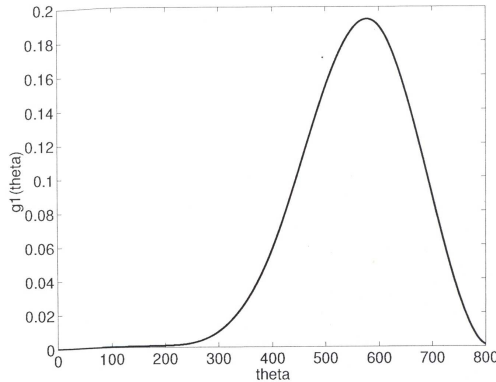

Figure 4: Plot of the transformation function  $g_1$ , depending on the temperature  $\theta$ .

$g_2$  has been taken constant as in [12], which has been found sufficient to describe the kinetics of the phase transition. The main coupling effect is through the carbon dependent start and end temperature of the martensite formation,  $M_s(c)$  and  $M_f(c)$  respectively, which have been identified from Figure 3.

The simulations were performed with *Femlab*, a software based on the finite element method.

Fig. 5 is a view of a sector of the sample configuration that we considered, after carburizing for about 8 hours.

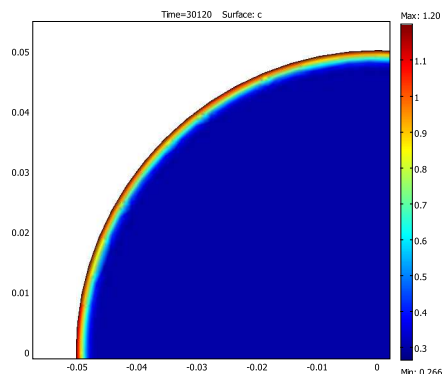
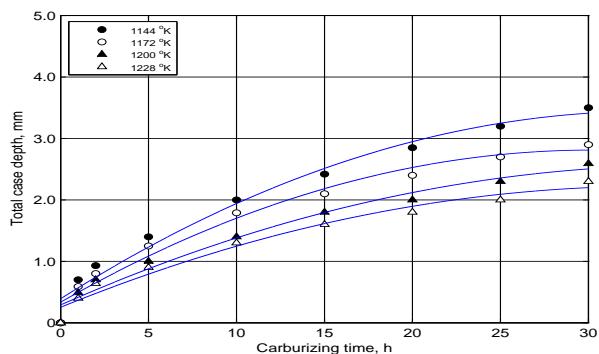

Figure 5: Snapshot of the simulation at time  $t = 30120$  s (after 30000 seconds carburizing and 120 seconds quenching) showing the carburizing effect. In the right column carbon percentage is indicated.



Time, h	1144°K mm	1172°K mm	1200°K mm	1228°K mm
1	0.41	0.49	0.59	0.70
2	0.64	0.70	0.80	0.93
5	0.90	1.00	1.25	1.40
10	1.30	1.40	1.79	2.00
15	1.60	1.80	2.10	2.42
20	1.80	2.00	2.40	2.85
25	2.00	2.30	2.70	3.20
30	2.30	2.59	2.90	3.40

Figure 6: Plot of total case depth versus carburizing time at four selected temperatures. Graph based on data in table.

As already said in the introduction the process consists at least of two stages: first, the workpiece is immersed in a carbon-rich atmosphere furnace (the so-called carburizing); secondly, quenching is performed, through which austenite is transformed into the hard phase martensite  $m$ , where the temperature gradient is high and into pearlite  $p$  where the temperature gradient is lower. In other words, the hardening occurs close to the boundary, while in the core the softer phase pearlite is formed.

The effect of time and temperature on total case depth (which is usually specified as the layer at carbon content 0.4%) is shown in Figure 6.

In Figure 7 we can observe the distribution of phase fractions at the end of a cycle of carburizing and quenching.

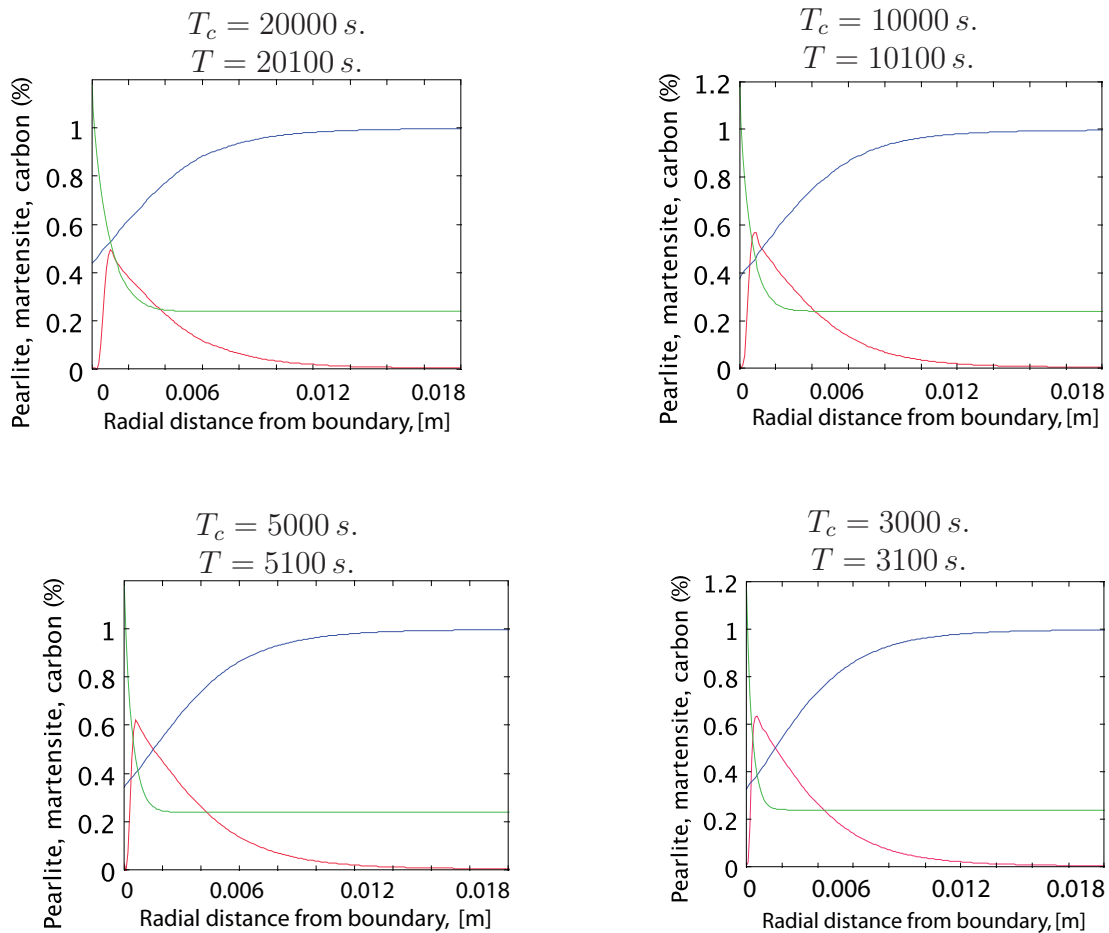

Figure 7: Phase fractions of martensite (red), pearlite (blue) and carbon percentage curve (green), plotted against the radius of the circle, for different carburizing times  $T_c$  and end times  $T$ , after a quenching time of 100 s.

In the same figure we can see how the formation of martensite depends on the carbon concentration, in accordance with the graphic of Figure 3 of the first section, obtained from experimental data. Indeed, as we can see in Figure 3, the martensite terminal temperature is well below zero, because of the residual austenite at room temperature which cannot be transformed into martensite, thus 100% of martensite is not achieved; in Figure 7, derived from our simulations, the maximum of the martensite phase fraction is about



65%. The maximum of the martensite fraction is not achieved on the surface, but at the total case depth, i.e. where the carbon concentration corresponds to 0.4%.

## 7 Concluding remarks

In the present paper we have studied a mathematical model of case hardening, including the coupling between carbon diffusion equation, temperature evolution and phase transitions. From mathematical point of view, we have proved existence and uniqueness of a solution. First numerical results confirm qualitative agreement with experiments. A more detailed comparison requires more precise data. To this end a cooperation with some engineering institutes has been started. The results will be published in a forthcoming paper.

From practical point of view, a reduction of energy consumption and of process time as well as increasing the process stability are of great interest. Therefore the development of an optimal control strategy is under study.

## References

- [1] American society for Metals, *Atlas of Isothermal Transformation and Cooling Transformation Diagram*, Ohio, (1977).
- [2] H. Amann, *Compact embeddings of vector-valued Sobolev and Besov spaces*, Glas. Mat. Vol 35(55) (2000), 161–177.
- [3] M. Avrami, *Kinetics of phase change*, J. Chem. Phys. 7–8–9 (1939, 1940, 1941).
- [4] R. Chatterjee-Fischer *Ueberblick ueber die Moeglichkeiten zur Verkuerzung der Aufkohlungsdauer*, HTM HÄdrtereitechn. Mitt. 40 (1985) 1, 7-11.
- [5] K. Chelminski, D. Hömberg, D. Kern, *On a thermomechanical model of phase transitions in steel*, to appear in: Adv. Math. Sci. Appl.
- [6] J. Fuhrmann, D. Hömberg, *Numerical simulation of the surface hardening of steel*, Intern. J. Num. Methods Heat Fluid Flow, 9 (1999), 705–724.
- [7] J.A. Griepentrog, *Sobolev-Morrey spaces associated with evolution equations*, Adv. in Diff. Eq. 12, 7 (2007), 781–840.
- [8] J.A. Griepentrog, *Maximal regularity for nonsmooth parabolic problems in Sobolev-Morrey spaces*, Adv. in Diff. Eq. 12, 9 (2007), 1031–1078.
- [9] D. Hömberg, *A mathematical model for the phase transitions in euctectoid carbon steel*, IMA J Appl. Math., 54 (1995), 31–57.
- [10] D. Hömberg, *A mathematical model for induction hardening including mechanical effects*, Nonlinear Anal. Real World Appl., 5 (2004), 55–90.

- [11] D. Hömberg, *Irreversible phase transitions in steel*, Math. Methods Appl. Sci, 20 (1997), 59–77.
- [12] D. Hömberg, W. Wolff, *PID-control of laser surface hardening of steel*, IEEE Trans. Control Syst. Technol., 14 (2006), 896–904.
- [13] H.P. Hougardy, *Die Darstellung des Umwandlungsverhaltens von Stählen in den ZTU-Schaubildern*, HTM Härtereitechn. Mitt. 33 (1978) 2, 63–70.
- [14] M. Hunkel, T. Lübben, F. Hoffmann, P. Mayr, *Using the jominy end-quench test for validation of thermo-metallurgical model parameters* J. Phys. IV France, 120 (2004), 571–579.
- [15] M. Hunkel, T. Lübben, O. Belkessam, U. Fritsching, F. Hoffmann, P. Mayr, *Modeling and Simulation of Coupled Gas and Material Behaviour during Gas Quenching* Proc. ASM 2001, Heat Treatment, Indianapolis, USA, (2001), 5–11.
- [16] H.W. Knobloch, F. Kappel, *Gewöhnliche Differentialgleichungen*, Teubner, (1974).
- [17] T. Inoue, T. Yamaguchi, Z. Wang *Stresses and phase transformations occurring in quenching of carburized steel gear wheel*, Mat. Sci. and Tech., 1 (1985), 872–876.
- [18] O.A. Ladyzenskaja, V.A. Solonnikov, N.N. Ural'ceva, *Linear and Quasilinear Equations of Parabolic Type*, Amer. Math. Soc. Transl. 23, AMS, Providence, RI, (1968).
- [19] J.L. Lions, *Quelques methodes de resolution des problemes aux limites non lineaires*, Gauthier-Villars, Paris, (1969).
- [20] J.L. Lions, E. Magenes, *Problèmes aux limites non homogènes*, Dunod, (1968).
- [21] M. Motoyama, R.E. Ricklefs, J.A. Larson *The effect of carburizing variables on residual stresses in hardened chromium steel*, SAE Technical Paper Series 750050, Society of Automotive Engineers, Feb 1975.
- [22] A. Ochsner, J. Gegner, G. Mishuris *Effect of diffusivity as a function of the method of computation of carbon concentration profiles in steel*, Met. Sci. Heat. Treat., 46, 3-4 (2004).
- [23] C.A. Stickels, *Gas carburizing*, ASM Handbook, Heat Treatment, (1997), 312–324.
- [24] G.G. Tibbetts, *Diffusivity of carbon in iron and steels at high temperatures*, J. Appl. Phys. 51 (1980), 4813–4816.
- [25] A. Visintin, *Mathematical models of solid-solid phase transitions in steel*, IMA J. Appl. Math., 30 (1987), 143–157.
- [26] E. Zeidler, *Nonlinear Functional Analysis and Its Applications*, Vol II, Springer, New York, (1990).