



Brandenburgische
Technische Universität
Cottbus - Senftenberg

14th EEEIC

International Conference on Environment and Electrical Engineering – Student Edition

Wrocław-Ostrava-Cottbus
8th – 12nd of June 2015

Harald Schwarz, Przemysław Janik,
Radomir Gono, Dirk Lehmann

module at BTU: 11396

ISBN 978-3-940471-35-2

organiser / veranstalter

Wroclaw University of Technology
Department of Electrical Engineering
pl. Grundwaldzki 13
PL 50 – 377 Wroclaw

Technical University of Cottbus
Department of Power Distribution and High Voltage Technology
Walther-Pauer-Straße 5
D – 03046 Cottbus

VŠB - Technical University of Ostrava
Department of Electrical Power Engineering
17. Listopadu
CZ - 15 Ostrava - Poruba

copyright

Dieses Werk einschließlich aller seiner Teile ist urheberrechtlich geschützt.
Alle Rechte, insbesondere die der Vervielfältigung, Verbreitung und Übersetzung liegen beim Verlage. Kein Teil des Werkes darf ohne Genehmigung des Verlages, auch nicht für Unterrichtszwecke, fotografiert oder auch durch andere Verfahren reproduziert und verbreitet werden. Ebenfalls ist eine Einspeicherung und Verarbeitung in EDV-Anlagen ohne Genehmigung des Verlages strafbar.

publisher / verlag

Brandenburgische Technische Universität Cottbus-Senftenberg
IKMZ-Universitätsbibliothek
© 2017
ISBN 978-3-940471-35-2

Table of contents

<u>Building of the first nuclear power plant in Poland</u>	1
<u>German Grid Development Plan 2014</u>	4
<u>Taxation of lignite power plants and its consequences for the Lausitz</u>	7
<u>Biogas</u>	10
<u>Nuclear Fusion</u>	14
<u>Cottbus on its way of becoming a Smart City</u>	17
<u>Wind turbine machines onshore</u>	20
<u>The Solar Flight around the World</u>	23
<u>Passive houses</u>	25
<u>Wind powered cars</u>	28
<u>Renewable Energies</u>	30

Building of the first nuclear power plant in Poland

public opinion

Jakub Lelo
BTU Cottbus-Senftenberg
eBusiness
Cottbus, Deutschland
jakub.lelo@gmail.com

Michał Rudziak
BTU Cottbus-Senftenberg
Informatik
Cottbus, Deutschland
michal.rudziak@gmail.com

Angelika Jedynak
BTU Cottbus-Senftenberg
Wirtschaftsingenieurwesen
Cottbus, Deutschland
angelika.jedynak@o2.pl

Nuclear energy seems to be the optimal solution to the problem of a still growing energy request. The profits and risks of a construction of a power plant divide the society since over 30 years. Such factors as nuclear disasters and government actions influence the point of view. The amount of the supporters and active protesters vary but the most decreasing number is the number of people who doesn't care or aren't informed about the topic.

I. INTRODUCTION

First information in polish media about the plans for building a nuclear power plant in Poland were published in 2008. The Ministry of Economy declared, that the construction should be realized by 2020 within the project: "Energy Politics till 2030" [1]. The Project Development of the first nuclear power plant in Poland has been started by government decision of 13 January 2009. In July 2009 Ministry of Economy has published a work schedule for nuclear power, which was divided into 4 stages: Preparation of the program, Creation of the law and institution infrastructure, Location arrangements and finally the Contract conclusion which was an agreement to build the first block of the nuclear power plant, drawing of the technical project and receiving of the build permission [2]. Former Deputy Prime Minister of Poland- Waldemar Pawlak declared in 2008 that the essential requirement for the building of the nuclear power plant in Poland is the approval of the society. Minister has assured that the government is prepared for the conservations with folk and guarantees the transparency and thoroughness of the information [3].

II. MAIN IDEA

From the social point of view nuclear power technology and its implementation guarantees profit for the households and economic sector. The existence of the nuclear power plant would expand the job market, create new study courses, cause

growth of the local companies and expansion of the regions. It's a source of cheap and clear energy, which could downgrade the price of the electric energy for the end customers. Thanks to the new source of energy Poland would have a chance to increase the reserves and become independent from fuel imports from other countries. Concerning the influence of nuclear power the energy mining in Poland would be more differentiated. It would also speed up manufacturing sector in Poland [4].

III. CITIZEN'S OPINION

Opinions on the subject vary. On the basis of GfK's Polonia public opinion polls from 2007 the majority of polish citizens, i.e. 57% was against building of the nuclear power plant in Poland, only 34% thought it would be the right choice and 9% had no opinion about this topic. The majority of the people with higher education were followers [4]. The results of the polls made by CBOS show alike data [5]. On the graphic "Diagramm 1" above can see the topical statistic from CBOS (Centre for Public Opinion Research). It epitomizes the changes of the attitudes towards nuclear power plant in Poland between the years 1987 and 2014. It's easy to recognize the main episodes, when the public opinion had been



Diagramm 1.

strongly influenced and had been changed. Chernobyl, Fukushima and acting of Polish government have been changing the point of view of the Polish citizens over the years. In our opinion there is one more thing that is worth mentioning. The number of supporters and opponents varies, but the count of people without opinion decreases constantly. People read more about this topic and form their own opinion. The consciousness of the consequences rises, because they will influence every Polish citizen.

IV. INFLUENCE OF NUCLEAR DISASTERS

On 26 April 1986 one of the most dramatic nuclear disasters took place. In Chernobyl (Ukraine) the fourth block of the nuclear power plant has exploded. Main causes were the construction faults of the reactor RBMK-1000 and wrong decisions of the inexperienced personal. As the result of the breakdown the radioactive contamination covered almost the whole Europe [6]. In 1987, a year after this catastrophe Greenpeace has made new polls among Polish citizens, who clearly changed their minds. The data shows, there were much more opponents than before. The folk already knew the horrifying consequences of reactor malfunction and was afraid, that it could happen in Poland as well [5]. The fear of the nation and the waves of protests caused the closure of the first nuclear plant in Żarnowiec in 1990 which was already finished but not operational. Thousands of very expensive montage tools were scrapped, sold out for very low prices or stolen. Because of the fact the country lost about 2 billion dollars [10]. The spirit of Polish citizens has changed a bit a few years after the disaster in Chernobyl together with publicity campaign of the Polish government in 2009. The government was trying to convince the folk with all the advantages and assure about safety of the investment in Poland [5]. Unfortunately it didn't take too long till the situation got worse again. On 11 March 2011 occurred new cataclysm in Japan- tsunami. The wave caused the destruction of fuel tanks that provided energy for emergency cooldown systems. The final result was the breakdown of three nuclear reactors in nuclear power station in Fukushima [7]. The radioactive contamination was again the main consequence of the malfunction. According to the International Atomic Energy Agency the catastrophe in Fukushima had a big influence on energy politics in other countries. On 6 June 2011 the German government has confirmed the decision to resign from nuclear power until the end of 2022 [8]. Other countries like Great Britain or France have declared to make the audit of their nuclear objects and started projects to increase the security of their older nuclear power plants [9].

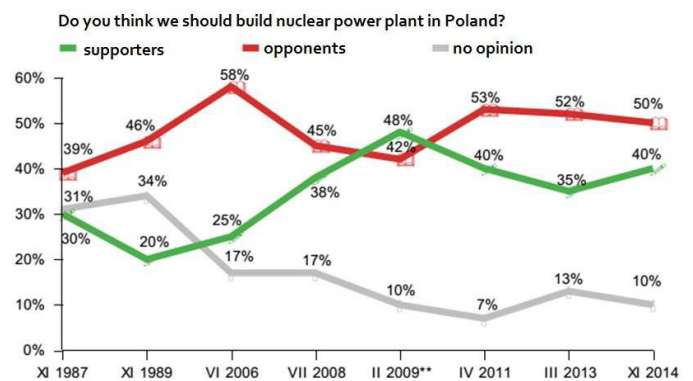
V. PROTESTS

According to Greenpeace's statistic the attitude towards building first nuclear power plant haven't change since 2011 [5]. The opinions of the Poles are still divided and the majority is against this new source of energy. In Poland do exist also other big companies which protect the natural environment e.g. Partia Zieloni (Green Party Poland), Towarzystwo na rzecz Ziemi, Towarzystwo Ornitologiczne or Mazowiecki Ośrodek Edukacji Ekologicznej. They often write petitions to the

highest government institutions or organize provocative demonstrations on the streets. One of the biggest protest against power plants in Poland took place one day before anniversary of the catastrophe in Fukushima in 2012. At this day the manifestations reached all the country e.g. Warsaw, Gdańsk and Szczecin. Some of the participants were representatives of the biggest ecology organizations and influential political persons. In Warsaw people from "Green Party 2004" met in front of the prime minister's office, wearing white masks and overalls. They took radioactive waste barrels and banners with slogans against building of the power plant with themselves. The leader of the party- Agnieszka Grzybek has appealed to the prime minister Donald Tusk to withdraw from this project.

In Szczecin citizens of: Mielno, Gąski and Darłowo have protested. The representatives of Green Party, Greenpeace, AntiAtomBündnis NordOst and Alliance '90/The Greens organized their own manifestations as well. One of the demonstrating woman took her top off and showed her three breasts which were supposed to be the side effect of the nuclear radiation. The protesters prepared an initialization of the alarm over environmental pollution. In Katowice Greenpeace members were giving Lugol's iodine to the pedestrians and examined their radiation with Geiger counter. They were trying to catch folk's attention and show them the real danger of nuclear power [13].

The ecologist from "Pomorska Incjatywa Antynuklearna" (Pomerania's Antinuclear Initiative) together with the others ecological organizations were also protesting near the building. This organizations perform regular demonstrations and conferences in Pomerania. They try to make the local society aware of the consequences, which the nuclear power plant can cause. The biggest protest in Pomerania took place on 26 April 2012 in Gdańsk, it has commemorated the 25. anniversary of the Catastrophe in Chernobyl [11].

On November 2011 three plausible localizations of the building have been officially confirmed: Choczewo (Voivodeship: Pomeranian), Gąski (Voivodeship: Kuyavian-Pomeranian) and Żarnowiec (Voivodeship: Pomeranian). This information caused new wave of discontent and protests, because the majority was not pleased to have a nuclear power plant near to the place of their own residences. In referendum, which took place in the local area, 90% citizens have voted against it. The most of them jointed the bigger organizations or organize constantly their own small protests on a regular basis. Every thirteen day of month the citizens of Gąski organize a mass meeting exactly at the place, where the nuclear power plant should be potentially build [12].

VI. DREADS AND ALTERNATIVE SOLUTIONS

The Ministry of Economy tries to convince the protesters that the construction of the Polish power plants will satisfy all requirements, even the most demanding. "The newest and safest technologies will be used." - promises Hanna Trojanowska, Government Commissioner for nuclear power [14]. The ecologists are not convinced. They accuse the government, that it does not give the real building cost, but the decreased one. In their opinion the security measures

accounted by Ministry of Economy are insufficient [13]. Many organizations claim that the only energy source which can assure the safety in Poland and bring tens of thousands new workplaces is the renewable energy like wind or sun [13]. Centrum Badań Opinii Społecznej (Center for Public Opinion Research) has made statistic in years 2009-2012 that shows, that the most Poles are standing for development of renewable energy. The second place still belongs to the nuclear power. The last place took the bituminous coal based energy policy. The latest questionnaire took place in 2014, almost everyone has voted for renewable energy [5]. However Poland doesn't have many possibilities to develop more water plants because already existing dams are disturbing natural environment. Because of the fact the government cannot make a decision to create many new water plants. The wind energy potential in the country is not satisfying as well because the wind flows are on relative low level and cannot cover the energy needs. Two alternative solutions that are technically possible are solar energy and geothermal energy. Unfortunately the technologies standing behind these two alternatives are very expensive making the atomic energy more attractive and reasonable solution for the future.

VII. SUMMARY

It's very hard to give a clear opinion about this topic. Nuclear power plant is a very efficient source of energy, but on the other hand, without any doubts the most dangerous one. In this situation the government stays on the opposite site to the citizens. The more government does in the way of nuclear power development, the more afraid the people are and the more demonstrations they prepare. Should the Ministry follow the will of the folk or take his own decision? It's definitely a tough decision. In addition, Poland is already in the third stage of the project and a lot of money had been already invested, so it's not so simple to change already taken direction.

- [1] A. Łakoma, "Atom już budzi kontrowersje", Rzeczpospolita, April 2008, in press.
- [2] Ministry of economy, "Ramowy harmonogram działań dla energetyki jądrowej", materiał informacyjny dla Rady Ministrów, Warsaw, 2009.
- [3] W. Pawlak, "Interpelacja w sprawie budowy na terenie Polski elektrowni atomowej", Warsaw, 8 July 2008.
- [4] Polskie Towarzystwo Nukleoniczne, "Energetyka Jądrowa-Perspektywy rozwoju w Polsce", Raport w MDI Strategic Solution, Warszawa, 2009, pp. 1-5,10-20.
- [5] Centrum Badań Opinii Społecznej, "Raport z badań ilościowych dla fundacji Greenpeace Polska", Warsaw, November 2014.
- [6] B. Moltmann, A. Sahn and M. Sapper, "Die Folgen von Tschernobyl", HAAG+HERCHEN Veral GmbH, Frankfurt am Main, 1994, pp. 45-54.
- [7] S. Boos, "Fukushima last sich grüßen: Die Folgen eines Super-GAU's", Rotpunktverlag, Zürich, 2012, pp. 32-34.
- [8] "Stufenweise AKW-Abschaltung: Scholz lobt Beschluss" Stufenweise AKW-Abschaltung: Scholz lobt Beschluss", Hamburger Abendblatt, 3 Juni 2011, in press.
- [9] Rafał Zasuń, "Czy tsunami zablokuje rozwój energetyki jądrowej na świecie, Gazeta Wyborcza", 14 March 2011, in press.
- [10] Janusz Waluszko, "Protesty przeciwko budowie elektrowni jądrowej Żarnowiec w latach 1985–1990", Gdańsk, 2013, pp.19,57-62.
- [11] K. Nietka, "W Gdańsku demonstrowali przeciwko budowie elektrowni jądrowej", 20 April 2011, in internet.
- [12] Internet site of the city of Mielno: <http://www.mielno.pl/zakladka/zawartosc/117/protesty-manifestacje/>
- [13] "Protesty przeciwko elektrowni atomowej", tvpinfo.pl, 10 March 2012.
- [14] "Protesty w całym kraju: nie dla atomu", polskieradio.pl, 10 March 2012.

German Grid Development Plan 2014

Authors: Robert Schneider, Thomas Meißner, Martin Heinrich, Mario Lange
BTU Cottbus, Chair of Power Distribution and High-Voltage Engineering
Cottbus, Germany

I. INTRODUCTION

In 2012 an elevation about the grid investments effected during the last years was published by the German federal agency and the German Federal Cartel Office by electricity providers and transmission grid operators. From it is arose that at last between 3.6 and 3.8 milliards € flowed into the removal of the German supply networks what is comparably with the investments in the beginning of the nineties. [1, p.60] Looked one the demands constantly rising in the today's time which are made to the German electricity grid becomes clear fast that comprehensive interior work is necessary to protect the electricity supply of Germany in the long term.

Above all the national energy policy which speeds up the removal of the renewable energy puts the grid before a great challenge, as well as the nuclear climbing out agreed in June, 2011 and the acceleration of the energy turnaround. [1, p. 25] As a result from it the removal of renewable energy was sped up with priority in North Germany, because there the best conditions for the use are given by wind energy and solar energy as well as biomass. At the same time the electricity production was reduced by conventional energy sources and nuclear energy. Now the care of the industrial locations in West and South Germany should be realized by the renewable energy of North Germany, what brings the momentary transmission grid to his load limits. [1, p. 57]

For the solution of this problem four transmission system operators Tennet, 50 Herz, Amprion and Transnet BW were instructed with the production of the Grid Development Plan (GDP). This shows the removal need of the German electricity grid within the next 10 years.

The conversion of the GDP should guarantee the security of supply by the grid taking into account the addition of other renewable energy sources and the other removal of the European home market. [2, p. 14]

II. GRID ANALYSIS

At the beginning of the grid analysis are the 3 different scenarios. The scenarios consist of various forecasts produced and consumed for the 2024 Energy. The Lead Scenario B is forecast beyond that even further to 2034. In order to assess to what extent grid expansion measures are necessary was carried out a comprehensive network analysis. The market

simulation program called BID3 has been developed only for the scenarios, it calculates the regional supply and consumption situation in Europe, for all 8760 hours of the year.

These calculations were based on existing input variables, such as the current energy demand and installed capacity and the definitions of restrictions and constraints hired. [2, p. 37-38]

The network must fulfill the (n-1) criterion in addition in each scenario. Here, the capacity of the electricity grid is being investigated in case of failure of a network element. The following figures show the one forecast for the utilization of the German Home network(Fig. 1) and the line load in the (n-1) case(Fig. 2) for the scenario B in 2024th(B24). Based on the network load data several measures have been derived in order to maintain the supply in the future.

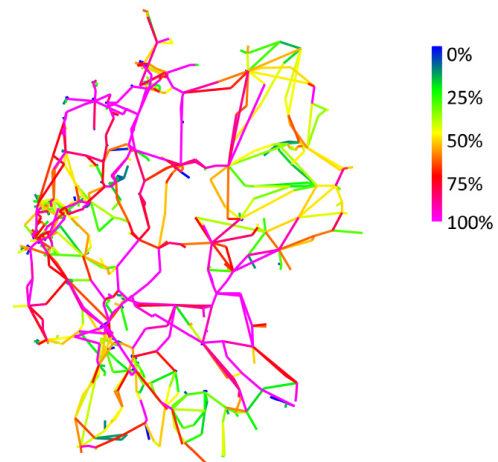

Quelle: ÜNB

Figure 1. German Home network[3, p.85]

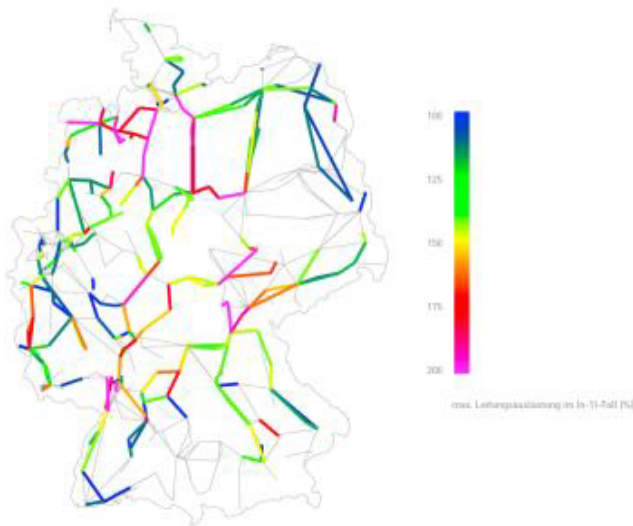

Figure 2. The line load in the (n-1) case

III. TAKEN STEPS OF THE GRID ANALYSIS

A. “Novaprinzip”

The existing grid is treated after the “Novaprinzip” with all the information’s of the scenarios, market simulation and grid analysis. The “Novaprinzip” means at first grid optimization, second grid gain and third grid expansion. One suggest the grid expansion, only after one has excluded the other options. These options are e.g. change of the wires or increase of the voltage from 220 KV to 380 KV. [2, p.18]

B. Overview of the grid expansion

In the 4 scenarios the expansion of the wind energy (onshore and offshore) has a big influence to the needed transmission capacity from the north to the south. This transmission capacity should provide by the 4 HVDC transmission lines. The scenarios vary slightly from each other in beginning, ending and transmission capacity.

C. The existing grid

The existing grid consist the following projects:

- the existing grid
- projects, which are necessary concerning the Energy Line Extension Act
- the construction projects
- project to fulfill other obligations

In the GDP are numerated 142 projects and 66 of them are line conversion or line construction. The Grid Expansion Acceleration Act of 2011 didn’t have the effect to focus the line constructions. If you compare the finalization, which are planned, of the GDP 2012 and the GDP 2014, you see e.g. 12

of the 27 project of the company Amprion are defaulting. [2, p.130]

D. Overview of construction projects (B24)

HVDC projects

- 7 projects
- Length of the lines are 3870 km
 - 2290 km are new construction
 - 158 0km are construction in existing lines
- Current status in GDP 2014
 - 4 projects are in process of planning
 - 3 project aren’t in process

Overhead power line

- 81 projects
- length of the lines are 4373.5 km
 - 689 km are new construction
 - 3684.5 km are construction in existing lines

IV. THE COSTS OF THE GRID DEVELOPMENT PLAN

The GDP has 4 different scenarios. The scenarios distinguish between the costs and the kind of constructions. It was considered on the one hand DC power lines and on the other AC power lines. Additionally there are grid expansions and there are new constructions of the grid.

According to some experts are the forecasted costs to high because the transmission system operators want pursue other objects than the specifications of the GDP.

The main part of this costs are depending of the topological area of the route of the power lines and of the voltage level. Only the power line cost between 30 and 50% of the whole construction costs. Additional there are the costs for substation with the transformers and other grip equipment. Normal high-voltage-wirings cost 1.4 mil €/km. There are further 20 million for each required substation. If there is a part undergrounding (till 46%) the cost rises to 2.9 mil €/km HVDC power lines are cheap but the additional equipment (e.g. DC/AC converter) are very expensive. This is the reason why this power lines are worthwhile at a long rage.

TABLE 1. Comparison of the scenarios

Scenario	Amount of investment	New Building of the DC grid	New building of the AC grid	Expansion of the existing grid
A 2024	22 Bil. €	2200 km	1300 km	5200 km
B 2024	23 Bil. €	2300 km	1300 km	5300 km
B 2034	no forecast	3700 km	1300 km	7100 km
C 2024	26 Bil. €	3400 km	1300 km	5700 km

- [1] Unterrichtung durch die Bundesregierung: Erster Monitoring-Bericht „Energie der Zukunft“
<http://dip21.bundestag.de/dip21/btd/17/119/1711958.pdf> [13.05.2015]
- [2] Zweiter Entwurf der Übertragungsnetzbetreiber Netzentwicklungsplan Strom 2014
- [3] Erster Entwurf der Übertragungsnetzbetreiber Netzentwicklungsplan Strom 2013
http://www.netzentwicklungsplan.de/_NEP_file_transfer/NEP_2014_2_Entwurf_Teil1.pdf [13.05.2015]
- [4] http://www.netzentwicklungsplan.de/_NEP_file_transfer/NEP_2013_Teil_1.pdf [13.05.2015]

Taxation of lignite power plants and its consequences for the Lausitz

Alexander Lehe

Industrial Engineering
BTU Cottbus Senftenberg
Cottbus, Germany
Alexander.Lehe@b-tu.de

Paul Goepfert

Industrial Engineering
BTU Cottbus Senftenberg
Cottbus, Germany
Paul.Goepfert@b-tu.de

Sascha Krauz

Industrial Engineering
BTU Cottbus Senftenberg
Cottbus, Germany
Sascha.Krauz@b-tu.de

Abstract—This paper looks at the region Lausitz, which is currently affected by the plans of the Ministry of Economy and Energy, to implement an additional fee for older fossil fuel fired power plants. It furthermore shows the effects of this so called climate contribution on the Lausitz.

Keywords—lignite; coal; Lusatia; energy; renewable; economy; climate; contribution; Lausitz

I. INTRODUCTION

The German energy industry performs a fundamental change for several years. With the creation of the Renewable Energy Act (REA) in 2000, the government laid foundations to convert the German energy system. Through the REA an economic framework was created to encourage investments in renewable energy. This break is called “Energiewende” (energy transition). The entire energy system of the Federal Republic of Germany will be transformed from a system which is based on nuclear energy and fossil fuels to a system which prioritizes renewable energies. In 2015 the Federal Minister of Economy and Energy Sigmar Gabriel came up with a new idea to impose a fee for old fossil power plants. This raised a nationwide uproar because it has a big impact on certain regions. One of these regions is the Lausitz, which is located in eastern part of Germany.

II. CHRONOLOGICAL DEVELOPMENT OF GERMAN ENERGY TURNAROUND

A. UNFCCC (1992) and Kyoto Protocol (1997)

In 1992 all UN countries met to determine the reduction of greenhouse gases. Since 1995 these countries meet annually to discuss the measures to control international emission of greenhouse gases. Especially the Kyoto Protocol in 1997 was a big milestone towards reaching the goals. On one hand the Protocol sets a reduction of the international emissions greenhouse gases by at least 5 % between the years 2008 and 2012 based on the amount of emissions in the year 1990. On the other hand a reduction of 18 % till 2020. Every single country is allowed to set its individual goals. So Germany decided to reduce their greenhouse gas emissions as shown more detailed in paragraph C [9].

B. European emission trading system (EUTS)

To reach the goals the European Union decided to implement a trading system for CO₂ emission certificates. This trading system doesn't seem to work very well, because all certificates can be traded to other European countries. That means that the total amount of emissions does not change. If one country reduces the emissions, the certificates it doesn't need are sold to other countries and the price of the certificates decreases. So it is an inefficient tool to reduce emissions.

C. German energy transition

TABLE I. GERMAN GHG REDUCTION PLANS [10]

Year	GHG reduction
2020	40 %
2030	55 %
2040	70 %
2050	80 – 95 %

To reach the national goals shown in Table 1, the German government decided to implement an energy system based on renewable energy sources (RES), energy efficiency and sustainability.

In order to achieve these objectives the German government passed a law (REA) to increase the share of renewable energy sources in the energy mix. The law is aiming towards the substitution of conventional energy sources by RES. There are fixed feed-in tariffs set to support the investments in RES. These tariffs are decreasing over time until a point is reached where the RES are profitable on market conditions.

D. Energy market 2.0 and climate contribution

Preparing the German energy market for future challenges is an important task. This can be accomplished by implementing the energy market 2.0. It comprises the following contents.

- Suppliers have to buy the amount of electric energy they have sold
- Encouragement of competition and innovation

- Fair pricing
- Privacy of smart technologies
- Capacity reserve

Only by using RES and increased energy efficiency the set goal of reduction by 2020 will probably not be reached. Because of that the ministry of economy and energy created the climate contribution. The way of working is explained in the following paragraph.

Every plant gets allowances to emit an amount of CO₂ per year. To be allowed to emit additional emissions they have to buy more certificates. All installations within the first 20 years of operation are exempted. This system especially affects older conventional power plants with high grade of emission [2].

III. IMPORTANCE OF LIGNITE FOR THE LAUSITZ

Lignite plays a particularly important role in the Lausitz, as there are five active lignite mines (Welzow-Süd, Jänschwalde, Cottbus-Nord, Nochten and Reichwalde), and three lignite-fired power plants (Table 2) in the region which generate more than 50 TWh of electricity annually, most of which is exported [4].

TABLE II. POWER PLANTS IN THE LAUSITZ [8]

Power Plant	Installed capacity	start up
Jänschwalde	3.000 MW	1989
Schwarze Pumpe	1.600 MW	1998
Boxberg	2.575 MW	1978 – 2012 ^a

a. units N/P 1978; unit Q 2000; unit R 2012

These three fossil fuel power plants (FFPP) cover 90% of the regional electricity production. The remaining 10% comes from renewable sources and cogeneration plants (CHP) (see figure 1).

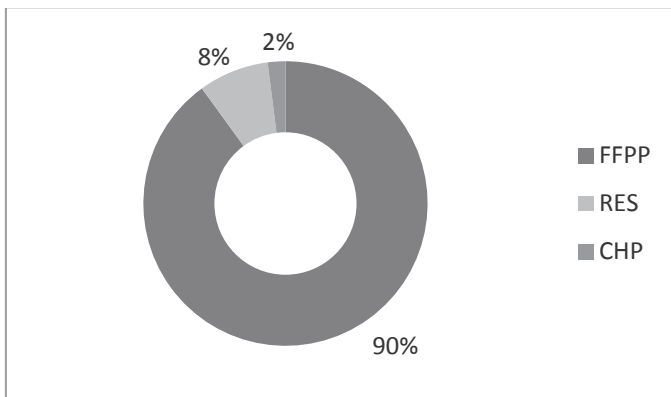

Figure 1. Regional electricity production [11]

The net product directly contributable to the lignite industry amounts to 812 million €. Additionally the industry induces more value-added effects. So a further 436 million € are generated by the purchase of goods and services in other

industries. The money spent on living and the consumption of employees has an additional value of 121 million €. All in all the lignite industry amounts to 1.369 billion € [1][4].

But not only the power generation and the net production accountable to lignite play a crucial role. The Lausitz as the former center of lignite mining in German Democratic Republic (GDR) is still dominated by the fossil energy, which thus constitutes the most important employers in the region. Despite the huge loss of jobs caused by the sharp decline in lignite industry after the unification of Germany, there are still 8.189 people in the Lausitz which are securing their livelihood by working in the lignite industry [1][5].

Therefore lignite is of great importance for the economy of the region Lausitz in the three areas of energy supply, value and wealth as well as job security.

IV. IMPACT OF CLIMATE CONTRIBUTION ON THE LAUSITZ

A. Direct impact on lignite industry

As to be seen in Table 2 all lignite power plants of the Lausitz are around 20 years old and thus they are directly affected by the climate contribution of the German government. Lignite power plants are used for base load supply only; hence they run many full load hours and emit a lot of CO₂. One MWh electricity generated by lignite emits roughly 1.000 kg CO₂. An additional CO₂-fee, analogical to the planned climate contribution, would suppress the lignite industry over time [6].

B. Impact on the Lausitz

1) *Impact on economy:* In case that the climate contribution is implemented a lot of sectors are affected. All upstream, midstream and downstream industries could lose their business basis. There would be no use for suppliers, maintenance tasks and other comparable businesses. All in all the future of many small and middle-class companies depends on the lignite industry. One third of the revenue of the lignite industry were contributed to those companies (based on 2010) [8].

2) *Impact on labor market:* As shown in paragraph 1 many companies depend on the lignite industry and therefore a lot of workplaces are impacted. In 1989/90 a similar event, the German unification, caused the loss of hundreds of thousands of professional jobs [5]. According to PROGNOSES (2011) the amount of jobs may decrease from 10.300 in 2010 to 5.890 in 2030 [1]. But another study by Greenpeace states, that many experts in the lignite industry could be retrained to work in the arising renewable sector [6].

3) *Impact on environment:* The primary objective of the German government is the climate protection. While burning fossil fuels (lignite) causes a lot of emissions, especially CO₂, RES cause almost zero emissions. So changing to a green energy system would support that objective. Also the substitution of lignite power plants will lead to higher average energy efficiency, which is another important goal of the government [3].

4) *Impact on the security of supply*: Lignite serves the base load demand. RES can't replace lignite as base load supplier as long as no efficient storage technologies are available. So if the share of RES is increasing, it may happen that the base load supply becomes unstable. This stands in conflict to the goal of the security of supply, which is guaranteed by the government [7].

V. CONCLUSION

The paper shows, that the planned climate contribution will probably have a huge impact on the Lausitz. It may affect the industry, economy, labor market, environment and security of supply. These effects are mainly negative but there are a few positive aspects e.g. saving CO₂ emissions. A particularly bad effect is the possible loss of many expert jobs. There is a study which shows, that these jobs aren't lost but instead these experts can be retrained to work in the renewable energy industry. However the training needs additional investments. Historically the Lausitz was connected to lignite mining and power generation and it should keep this connection. The energy transition cannot be done without lignite power generation, but on the other hand, the lignite industry has to make concessions to implement renewable energies.

REFERENCES

- [1] Prognos, Bedeutung der Braunkohle in Ostdeutschland, Berlin, 2011
- [2] Ministry of Economy and Energy Germany, Eckpunktepapier Strommarkt, Berlin, 2015
- [3] Lechtenböhrer S., Braunkohle ein subventionsfreier Energieträger?, Wuppertal, 2004
- [4] Regionale Planungsgemeinschaft Lausitz-Spreewald, Regionales Energiekonzept Lausitz-Spreewald, Cottbus, 2013.
- [5] D. Keppler, E. Töpfer, Die Akzeptanz und Nutzung erneuerbarer Energien in der "Energierregion" Lausitz, Berlin, 2006
- [6] K. Heinbach, M. Bost, S. Salecki, J. Weiß, "Vattenfalls Chance – Eine Zukunft für die Lausitz ohne Braunkohle, Berlin, 2015
- [7] I. Bachl/U. Goerke/A. Schmitz, Erneuerbare Energien – Chance für die Zukunft?http://www.planet-wissen.de/natur/technik/energie/alternative_energien/ [14.04.2015].
- [8] Vattenfall, "Braunkohle - Energie mit Zukunft", Berlin/Koeln, 2012
- [9] Ministry of Economy and Energy, "Kyoto-Protokoll," <http://www.bmub.bund.de/themen/klima-energie/klimaschutz/internationale-klimapolitik/kyoto-protokoll/>, [18.06.2015]
- [10] Ministry of Environment, *Das Energiekonzept der Bundesregierung 2010*. Berlin 2010
- [11] 50Hertz Transmission, "Regionale Energienetzbetreiber 2012", Berlin 2012

Biogas

Comparison of desulfurization methods

Aydin, Bilgin

Faculty 3 - Mechanical, Electrical and Industrial Engineering
Chair of Power Distribution and High-Voltage Engineering
Cottbus, Germany

Hamid, Hafiz

Faculty 3 - Mechanical, Electrical and Industrial Engineering
Chair of Power Distribution and High-Voltage Engineering
Cottbus, Germany

Mohammedani, Abdallah

Faculty 3 - Mechanical, Electrical and Industrial Engineering
Chair of Power Distribution and High-Voltage Engineering
Cottbus, Germany

Sena, Alam

Faculty 2 - Architecture, Civil Engineering and Urban Planning
Cottbus, Germany

Abstract Hydrogen sulfide is a highly toxic gas and could be a major threat to life if inhaled in large amounts, other than that it is a highly corrosive material, which deteriorates the function of engines. Therefore its removal is very essential in biogas development.

Keywords-component; biogas, sulfur removal, hydrogen sulfide

I. INTRODUCTION

It is known that the importance of renewable energy is in daily increase. One of the alternatives that are used as renewable energy source is the Biogas facility. This facility employs the fermentation of the biomass that is commonly known as Biogas. The Biogas is used to generate electricity and heat which could be used in the CHPs (Combined heat and power Unit) or processed as a biofuel in a gas processing plant .

As Biomass is following required:

- Energy plants: canola and corn.
- Agricultural waste: wood, litter, liquid manure and dung.

These are added in the fermenter, where it is kept away from light and oxygen. The biogas is then generated through the anaerobic fermentation of the biomass and forms gases like methane and carbon dioxide. The energy generated is proportional to the amount of methane gas resulting from the process. The residual materials could be used as a very good fertilizer [6]. This develops a cycle where the product and the residual are both used, and makes the Biogas a very good choice when addressing renewable energies.

Along the biogas another gases are generated like nitrogen, oxygen and H_2S which can be declared as the most critical side products on biogas development [7]. Therefore in this

paper we are going to target this issue and compare different technologies that are used in H_2S removal.

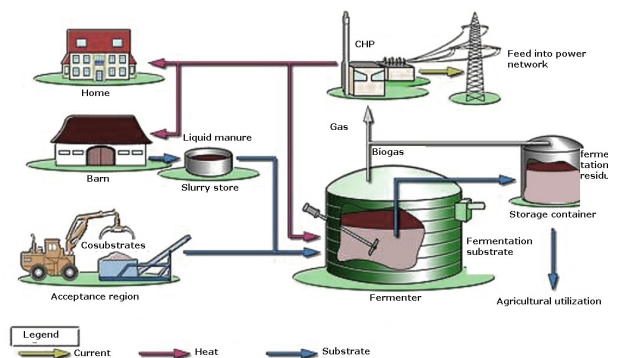

Figure 1: Principle of biogas facility [10]

II. THE FORMATION AND CHARACTERISTICS OF H_2S

Sulfur is found through the applied substrate and water in the fermenter. There it will be formed into H_2S through anaerobic microbial reactions. Its concentration will increase according to the decrease of the pH value of the substrate [3].

The H_2S is very toxic, low amounts of it could cause an irritation in the mucous membranes of the eyes and breathing airway. A concentration of 1000ppm and above when breathed could lead to death within seconds [2].

Other than that the H₂S is highly corrosive, the effectiveness of the microorganisms that create methane gas would be inhibited, which reduces the amount of biogas and accordingly the amount of energy. H₂S deteriorates the function of oxidizing catalysts of the motors, which is very important for emission control [3].

These problems affect the production and use of biogas, therefore desulfurization is a very important step in the process.

III. BIOLOGICAL DESULFURIZATION PROCESS

A. Desulfurization by addition of air:

This method is usually used for a rough cleaning of hydrogen sulfide. The air is fed into the gas space of the biogas fermenter, more exact at the interface between gaseous and liquid phase, where desulfurizing microorganisms so called sulfur bacteria have optimal living conditions. This bacteria affect the oxidation process of hydrogen sulfide produces by the fed air. Therefore elementary sulfur is formed which flows as yellow layer above the surface of the liquid phase. The chemical reaction shown in following formula:

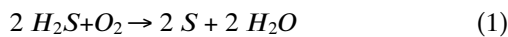

When the distribution of fed air is irregular, the oxidation of H₂S can generate sulfurous acid. This product is highly corrosive and causes problems in the interface between the phases [3] [4].

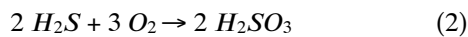

Better conditions for air desulfurization can be created in a secondary fermenter, so that the treatment area for sulfur bacteria can be increased. This increases the effectiveness of desulfurizing microorganisms [4].

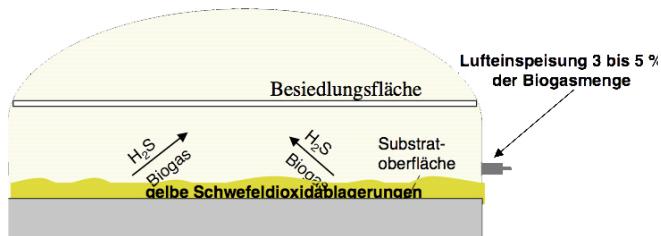

erfordert: Besiedlungsfläche, Temperatur, Zeit, gleichmäßiger Gasvolumenstrom

→ z.T. begrenzt Wirksamkeit

Figure 2: Process of desulfurization by air [9]

Advantages:

- Low cost.
- Flexibility in application.
- Easier to apply.

Disadvantages:

- Formation of sulfurous acid which leads to massive corrosion damage.
- Biogas is not suitable for natural gas network.
- Significant decrease in the concentration of methane.
- Gas quality can't be estimated. H₂S concentrations of 500ppm to 2000ppm are possible [5].

IV. PHYSIOCHEMICAL PROCESS

A. Ferric compounds

The Sulfur removal with Ferric compound happens before it starts turning into Gas. This procedure happens either in a preliminary tank or directly in the fermenter, where it is added to the substrate.

Accordingly it is possible for the ferric compound to bond with H₂S directly in the fermenter [3]. This process is only used in combination with the method of air desulfurization, because it is not possible for the H₂S to be removed in the gaseous phase with the use of ferric compounds [4]. In principle H₂S concentrations lower than 10ppm are possible [5].

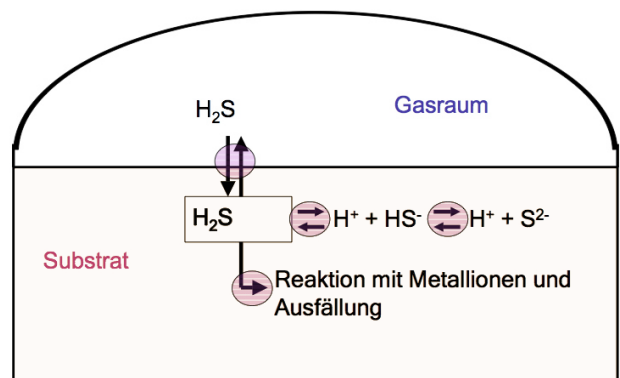

Figure 3: Process of desulfurization by ferric compounds [9]

1. Ferric (II) Chloride

The most common used ferric compound is the iron salt or ferric (II) chloride, its reaction happens in the substrate with the sulfide ions, which results that H₂S can't be generated, the chemical reaction is shown in the following formula [8]:



The iron sulfide is a not easily soluble compound which allows its removal from the system [2].

Advantages:

- The bonding of H₂S in the fermenter which leads to a better methane formation.
- A clear relationship between H₂S concentration and iron salt, which allows for a good estimation of the added value.

- This method is very effective in reducing high H₂S levels and doesn't require a complex process.

Disadvantages:

- Very strict rules regarding the storage of iron salts.
- This method can be regarded as a partial removal process and must be used in conjunction with another technology to achieve higher H₂S reduction.
- A possibility of change in the pH value in the substrate which inhibits the methane formation.
- Method is only economical when reducing high H₂S concentrations.

2. Ferric hydroxide:

The reaction of ferric hydroxide happens in two steps. The iron (III) will be reduced in anaerobic conditions to iron (II) in which the elementary sulfur is produced.

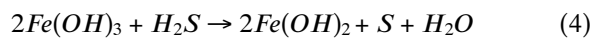

The iron (II) reacts with H₂S which results in iron sulfide that could be removed from the system [3].

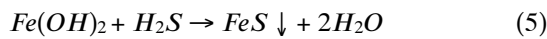

Advantages:

- Very effective
- Easy and harmless handling
- No change in the pH-value by adding big amounts of ferric hydroxide.

Disadvantages:

- Process is highly chemical intensive.
- More expensive
- Continuous dosing is required.

B. Activated carbon

This method is mostly used along with rough desulfurization methods like air or iron salt desulfurization.

If the biogas is going to be used in the natural gas grid, then the air desulfurization should be avoided, because the amount of oxygen needs to be reduced again [2].

The activated carbon is applied in a filter form. The biogas flows through this filter, where the oxygen and H₂S bond on the surface and split.

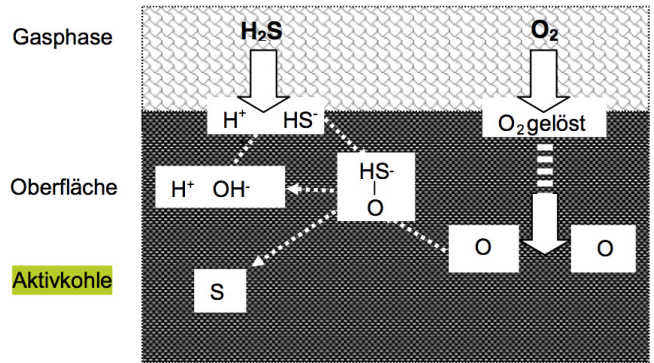
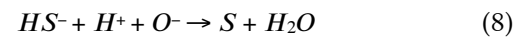

Figure 4: Process of desulfurization by activated carbon [9]

The dissociated hydrogen sulfide ($HS^- + H^+$) reacts when contacted with (O^-).



The resulting elementary sulfur will bind to the activated carbon. When the loading capacity of the activated carbon filter is reached, it should be replaced [7].

In this process H₂S concentration of lower than 1ppm can be reached [5].

Advantages:

- The desulfurization degree is very high.
- By changing the activated carbon filters, other gases are also removed like Halogen compounds and Siloxane.

Disadvantages:

- High consumption of activated carbon, when not well pre-cleaned, will lead to high running costs.
- It is not possible to set the H₂S concentrations with the amount of activated carbon filters.

V. CONCLUSION

Biogas is a promising source of energy. Because of its environmental friendliness and the use of biomass it is a good way to satisfy people demands for energy and to reduce the greenhouse effect. It is clear that we will reach a point, where all the fossil fuels will be depleted, so it is better to find an alternative, which could replace energy sources such as coal, gas or oil.

A sufficient desulfurization of biogas is an essential requirement in the development process. Therefore we have introduced different methods. The comparison of them provides the following results: The information about the used substrates and its H₂S concentration is the first step before deciding which method to use. The air desulfurization is the cheapest way. However its effectiveness is the lowest. Iron compounds are better alternative solutions with higher efficiency, but they are quite expensive, because of their running costs. Activated carbon provides the best option for desulfurization. But because of its high costs it should only be used for

low H₂S concentration. More research work for these desulfurizing methods is still need to be done to make the use of biogas more attractive.

REFERENCES

1. Herbert Zölsmann, Andreas Mielke, Stefan Fischer, Christian Marx, Mathias Effenberger; Technical document: "Entschwefelung von Biogas in landwirtschaftlichen Biogasanlagen", Freising, Nr. IV – 10/2013
2. KRONOS INTERNATIONAL, Inc., Technical information 5.01: "Schwefelwasserstoffelimination aus Biogas", 2010
3. HeGo Biotec GmbH, Dr. Andreas Otto, Dipl.-Ing. Detlef Gübhaber, Dipl.-Ing. agr. Jenny Conrad: "Möglichkeiten des Einsatzes von Eisenhydroxid für die Bindung von Schwefelwasserstoff in Anaerob-Prozessen"
4. Technical document: "Der Schwefel muss raus", 2/2007 <http://biogas-infoboard.de/pdf/Seiten%20aus%20LZ702090.pdf>
5. Ralf L. Schneider, Dissertation: "Biologische Entschwefelung von Biogas", München 2007
6. Kai Henning: "Biofilter und Biowäscher", Economica-Verl., pp. 230-251, Bonn 1998
7. Andreas Polster, Joachim Brummack: „Verbesserung von Entschwefelungsverfahren in landwirtschaftlichen Biogasanlagen“, TU-Dresden 2005
8. L. B. Allegue and J. Hinge, "Biogas upgrading Evaluation of methods for H₂S removal," Danish Technol. Inst., no. December, pp. 1–31, 2014.
9. G. Reinhold, Vortrag auf der Beratung Arbeitsgruppe Biogas des TBV: "Entschwefelung - eine Herausforderung an die Betreiber von Biogasanlagen", Bösleben 2005
10. Fachagentur Nachwachsende Rohstoffe e.V. - www.bio-energie.de/biogas/anlagentechnik.html, 23.06.2015

Nuclear Fusion

... safe energy source of the future?

Sven Wählisch

Faculty 3 – Mechanical Engineering
Chair of Power Distribution and
High-Voltage Engineering
Cottbus, Germany

Michael Messerschmidt

Faculty 3 – Electrical Engineering
Chair of Power Distribution and
High-Voltage Engineering
Cottbus, Germany

Oliver Niefer

Faculty 3 – Mechanical Engineering
Chair of Power Distribution and
High-Voltage Engineering
Rehfelde, Germany

I. INTRODUCTION

Nuclear fusion is an important natural process: Many chemical elements originate from hydrogen through fusion; fusion is the energy source of the sun and stars.

The goal of fusion research is to derive energy from fusion of atomic nuclei. Under terrestrial conditions it is the two hydrogen isotopes, deuterium and tritium, that fuse most readily. In the process a helium nucleus is produced, this being accompanied by release of a neutron and large quantities of useful energy: One gram of fuel could generate 90,000 kilowatt-hours of energy in a power plant – the combustion heat of 11 tonnes of coal. [1]

II. HISTORY

The first time a fusion reaction was observed in year 1919 when Ernest Rutherford created an oxygen isotope by bombarding nitrogen with alpha particles. [2] Ten years later in 1929 the first conjectures about the fusion of small atomic nuclei being the energy source of the sun and other stars were made. These theories were based on Robert Atkinson's and Fritz Houterman's researches which were proved by Hans Bethe in year 1938. Rutherford's next success was when he could accomplish the first deuterium-deuterium- and deuterium-tritium-fusion reaction in 1934. Especially these experiments became very important for further fusion experiments and future nuclear fusion projects. Only one year after Bethe proved the theories of Atkinson and Houterman, he and Carl Friedrich Weizsäcker were able to give a quantitative description about the entire fusion process inside the sun. Theories were proved, experiments were made but no one was actually sure whether nuclear fusion is possible to be used on our planet until the year 1950. The development of the hydrogen bomb (H-bomb) - two years later the USA fired the H-bomb (with the code-name Ivy Mike) the first time- made people believe and even witnessed that nuclear fusion could be really used on earth. But additionally, the H-bomb, an uncontrolled nuclear fusion reaction, made nuclear fusion get more and more criticized and even almost socially rejected. Until year 1958 most projects and labors have been kept a secret but after the second Geneva Conference everything changed and a peaceful utilization of nuclear energy was found. The most interest in nuclear fusion were offered by the USA and the Soviet Union and even some European countries, especially the United Kingdom. [3] & [4]

A lot of time passed and some experiments were made mostly in vain until the breakthrough in 1991. The first power generation by controlled nuclear fusion was achieved and an actually at that time appreciable amount of energy has been released. Plus, 6 years later scientists were able to win an even higher fusion power than years before. [5] These days scientists from the United States even overcame the breakthrough of 1991. They succeeded a nuclear fusion where the energy balance was different than before. It was possible to gain a higher amount of energy than the amount that was put into the reaction. This progress made people believe in nuclear fusion for the future. [6]

III. PLASMA

With increasing temperature, all materials are successively transformed from the solid to the liquid and then to the gaseous state. If the temperature is further increased, one gets plasma, the "fourth aggregate state of matter".

In a plasma the atoms of the gas decompose into their constituents, electrons and nuclei. Everyday examples are the plasma column in a neon tube, an electric spark or the plasma streak of lightning.

A. Ignition Conditions

In a burning plasma a sufficient number of particles must collide with one another with sufficient frequency and intensity. The magnetic field cage must thus confine a sufficient number of particles whose thermal energy must not be transferred too quickly to the surroundings. This imposes requirements on the density, temperature, and thermal insulation of the plasma. These are:

- a plasma temperature of at least 100 million degrees
- an energy confinement time of about two seconds
- a plasma density of about 10^{14} particles per cubic centimetre – 250,000 times thinner than the earth's air mantle. This extremely low density means that, despite its high temperature, a burning fusion plasma affords a power density scarcely larger than an ordinary light bulb.

B. Magnetic Confinement

Owing to its high temperature a fusion plasma cannot be confined direct in material vessels. Any wall contact would immediately re-cool the thin gas. The problem is obviated by using magnetic fields, which confine and thermally insulate the fuel, keeping it away from the vessel walls.

Charged particles – ions and electrons – are forced in a magnetic field into circular and helical orbits around the magnetic field lines. The particles are thus tied to the field lines. In a suitably shaped magnetic field cage it is therefore possible to confine a plasma and keep it away from material walls.

C. Plasma Heating

Till ignition the plasma has to be externally heated. Several methods are available for this purpose.

- Current Heating
- High-frequency heating – "microwave oven" principle
- Neutral particle heating

IV. TYPES OF FUSION DEVICES

On its way to a power plant fusion research is concentrating on two different types of experiment, the tokamak and the stellarator.

Most of the devices in the world today are of the tokamak type. It is best investigated and comes closest to the ignition conditions.

Both types feature ring-shaped magnetic fields. Tokamaks produce part of these fields by means of an electric current flowing in the plasma. Stellarators, on the other hand, form the magnetic field cage solely by means of external coils. Stellarators are thus suitable for continuous operation, whereas tokamaks without auxiliary facilities can only work in pulsed mode.

A. Tokamak

To construct the magnetic field cage a tokamak requires three superposed magnetic fields: Firstly, a ring-shaped field produced by plane external coils; secondly, the field of a current flowing in the plasma. The field lines of the combined field are then helical. This is what produces twisting of the field lines and formation of magnetic surfaces, which are necessary for confining the plasma. A third, vertical field fixes the position of the current in the plasma.

The plasma current is normally induced by a transformer coil. This is why a tokamak does not work in continuous, but in pulsed mode: In a transformer it is only for a limited time that an increasing current can be generated in the primary winding so that a current can be driven in the plasma. The transformer must, then be "discharged" and the current started up afresh.

In order to achieve steady state operation in a future tokamak power plant, investigations are being conducted on methods of generating current in continuous mode, e.g. by means of high-frequency waves.

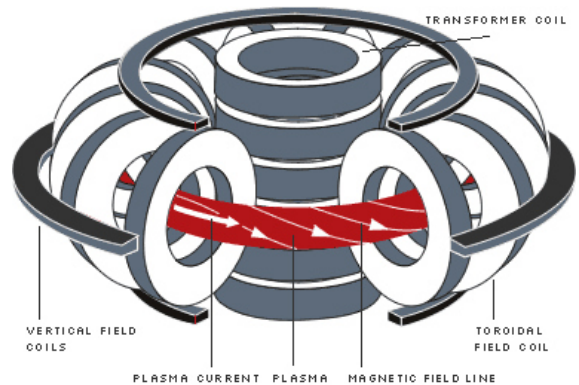

Fig.1: Basic schema of a toroidal confinement fusion reactor

B. Stellarator

In a stellarator the magnetic cage is produced with a single coil system – without a longitudinal net-current in the plasma and hence without a transformer. This makes stellarators suitable for continuous operation, whereas tokamaks without auxiliary facilities operate in pulsed mode.

Dispensing with the ring-shaped plasma current means, however, abandoning the axial symmetry present in tokamaks. As the helical twisting of field lines is achieved solely with external coils, the latter have to be twisted accordingly: the magnet coils and plasma have a complicated shape. This, however, affords additional freedoms in shaping the magnetic field and making its properties accessible to optimisation.

In order to overcome the deficiencies of previous stellarators, IPP conducted a systematic search for the optimum magnetic field. For more than ten years the Stellarator Theory Group investigated the wide area of possible stellarator configurations. The outcome is the optimised magnetic field of Wendelstein 7-X: The quality of plasma equilibrium and confinement will be on a par with that of a tokamak.

For a fusion power plant stellarators could provide a technically simpler solution than what tokamaks might achieve. This question cannot be answered by theoretical means; clarifying it experimentally is the objective of the Wendelstein experiments at IPP.



Fig.2: Magnets and plasma of Wendelstein 7-AS stellarator

V. FUSION POWER PLANT

Over ninety per cent of the world's energy requirements are covered today by fossil energy sources. The reliability of present supplies readily obscures the fact that the climate problem, limited fuel resources, and political instability call in the long run for a new energy system – away from coal, oil, and gas. Apart from renewable sources and nuclear fission, the only other alternative is fusion.

The raw materials for fusion are available everywhere in almost unlimited quantities. A fusion power plant will not produce any climate-impairing gases and promises favourable safety properties. Fusion could therefore make a lasting contribution to energy supply of the future.

- **Layout and Function**

The hot deuterium-tritium plasma in a ring-shaped combustion chamber is kept away from the "first wall" by magnetic fields. Till ignition a start-up heating system supplies the plasma for a few seconds with a power of 50 to 100 megawatts. The fast helium nuclei resulting from the ensuing fusion reactions are trapped in the magnetic field as charged particles and transfer their energy to the plasma through particle collisions. Ultimately, external heating can be almost totally switched off; the plasma maintains the fusion temperatures through self-heating.

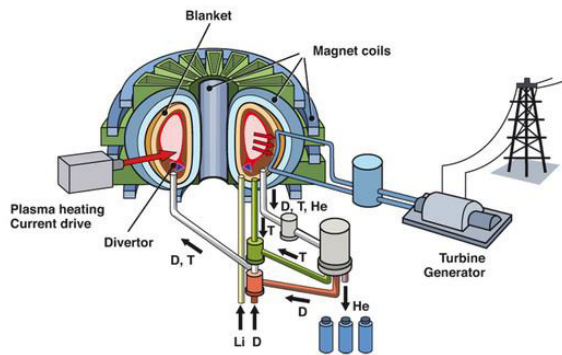

Fig.3: Layout of a future tokamak fusion power plant

- **Safety and Environment**

Climatically harmful emission does not occur in a fusion power plant. Safety precautions are necessary because of the radioactive tritium and high-energy neutrons, which activate the walls of the plasma vessel.

A fusion power plant has an important property ordained by nature: It can be designed in such a way that it does not contain any energy sources that – should they get out of control – could destroy a safety shield from the inside.

- **What is the status of fusion research? What physical and technological problems have still to be solved?**

With the international ITER experimental reactor fusion research is to proceed to demonstration of an energy-yielding plasma. If successful, ITER will open

the door to a fusion power plant. Present planning supposes that ITER will be followed up with a demonstration power plant supplying the grid with power. It is to prove that fusion energy can be reliably produced. This device, called DEMO, would no longer be an experimental device, but a power plant optimised to a single point of operation. This calls for a fundamental physical understanding of the system so that its properties can be calculated beforehand in detail.

Clarifying the physical principles of a fusion power plant will therefore continue to be an important objective and will occupy theoretical and experimental plasma physicists for some time yet. This will be paralleled by further development of the special technologies needed for a power plant, e.g. for plasma heating and for the blanket.

VI. CONCLUSION

Nuclear fusion is a promising source of energy, which could someday solve the world's energy problems. Through its environmental friendliness and its theoretical high energy balances, fusion power plants could replace other large power plants. It is clear that we will reach a point, where all the fossil fuels will be depleted, so we have to them. Renewable energy sources like solar panels or wind turbines could be an option, but there is a huge amount of disadvantages in comparison to nuclear fusion. The infrastructure and the capacity of saving energy have to be expanded to guarantee a stable energy supply [7]. To replace a power plant with 2000 MW you would need 12,5 km² (1750 soccer-fields) of solar panels or 1000 wind turbines provided that the sun is shining or wind is blowing [8] & [9]. Nuclear fusion would be the best solution for energy problems that are facing us. Especially the ITER project is one of the important ones, because it's targeted to be a prototype of a nuclear fusion reactor. When the construction of the reactor is completed, several methods will be tested to fix the remaining problems. This will take a lot of time, but it will be worth waiting for it.

REFERENCES

- [1] Max-Planck-Institut für Plasmaphysik: www.ipp.mpg.de
- [2] www.wikipedia.org/wiki/Ernest_Rutherford (Rutherford and the gold foil experiment)
- [3] www.schreiben10.com/referate/Physik/7/Physik-Spezialgebiet---Die-Kernfusion-reon.php
- [4] www.private.freepage.de/cgi-bin/feets/freepage_ext/41030x030A/rewrite/fusion/history.html
- [5] www.wikipedia.org/wiki/Kernfusionsreaktor#Erfolge_in_der_EU_und_den_USA
- [6] www.zeit.de/wissen/2014-02/kernfusion-energie-erfolg-usa
- [7] www.stern.de/politik/deutschland/studie-des-umweltbundesamtes-erneuerbare-energien-koennen-strombedarf-der-zukunft-decken-1580849.html
- [8] www.vestas.com/en/products_and_services/turbines/v110-2_0_mw#!at-a-glance
- [9] www.yinglisolar.com/de/products/multicrystalline/yge-72-cell-series/

Cottbus on its way of becoming a Smart City

The opportunities of Smart Grids in combination with variable tariffs for electricity supply

Maria-Liisa Bruckert
Gabriel Schoeneich

Faculty of Mechanical, Electrical and Industrial Engineering
of the Brandenburg University of Technology Cottbus - Senftenberg
Cottbus, Germany

Abstract—Urban areas developing to Smart Cities can be an important tool to cope with the challenges of our time like global warming and the efforts that are made towards an energy transition. Therefore, the question of the meaning of a Smart City is an important one. One of the central components is the Smart Grid, a system of managing and distributing energy, which deals with the challenge of decentralized renewable units. In addition to the Smart Meters in this grid, incentives to use the power intelligent, means efficient, can be implemented via variable tariffs for electricity supply. Caused by it's special energy production situation the so called "Energy Region" and the city of Cottbus are worth to have a closer view on. A lot of challenges need to be addressed, but Cottbus and the whole region are in a good starting position to take the lead in this development.

I. INTRODUCTION

The knowledge of global warming and the related need of emissions reduction, especially carbon dioxide, is not new, neither is the discussion about it. However, in the venture of protecting our climate, 2015 could mark a milestone in the international cooperation.

At the G7 summit 2015 in Germany the leaders of the world's major industries agreed to limit global warming to 2°C compared with pre-industrial levels and pledged to develop long-term strategies to achieve decarbonisation by the end of this century [1]. Furthermore in his encyclical letter *Laudato Si'* from May 2015 pope Francis focussed on the earth as our common home and reminds us, that we are all united in the same concerns and need to stand together to fight global warming [2].

To achieve an ambitious goal like the reduction of greenhouse gas emissions of 40 to 70% in 2050 compared to 2010, great achievements are needed on the global level as well as in each country, region and down to the private household.

In June 2015 the association of German Cities (Deutscher Städtetag) discussed the increasing difference between

financially weak and strong cities. Besides demands for specific support of the weakest cities and more help from federal and regional authorities in general, there was a consensus, that the cities should invest in their sustainable development and focus on concrete activities and parameters to cope with the future challenges [3].

Cottbus could be seen as a great example of the changes that have to be made. With turning away from fossil fuels, especially lignite, which is a major employment factor of the region, Cottbus and the Lausitz region have to find ways to shape their future in times of the German energy transition. This might be a chance to not only manage the inevitable, but to create new opportunities for the city and the whole region.

The former lignite mining areas are more and more transforming into beautiful touristic venues, called the Ostsee-Region. Looking into the future a little further, Cottbus should also think about the opportunities of becoming a Smart City. And maybe a small city like Cottbus is even more likely to achieve such an ambitious goal than a metropolis.

II. DEFINITION OF A SMART CITY

There is no general definition of a Smart City yet, but since the late 1990s, when the term was first established, it developed to an idea of the city of the future. Cities play a vital role in coping with the challenges of climate change. They are the center of life and work of the majority of people and they provide the infrastructure necessary to make the changes to approach a carbon free society.

The Smart City idea contains solutions for the infrastructure of energy and transportation, for environmental sustainability, the integration of the municipal economy, guided by forward-looking Governance to focus on people and their quality of life. These fields of activity are connected by an integrated information and communication system. Figure 1 visualises the main components of a Smart City [4].

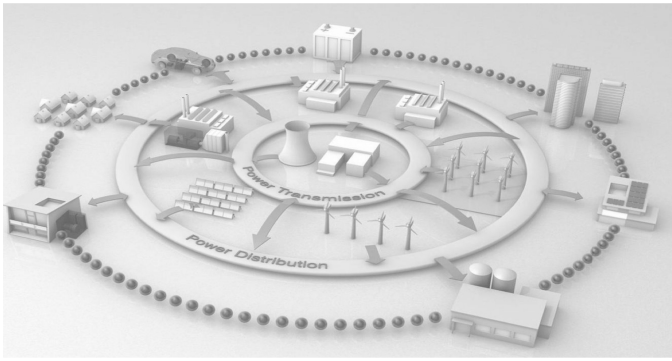

Figure 1: Components of a Smart City [5]

Superior and key point is the management system of the Smart City concept. The coalescence of information and technical data is the base for the operation and control of this kind of system. In combination with good Governance, clear rules and transparency are responsible for filling the idea with life and ensure a frictionless implementation. To ensure the realisation of all the components, city development concepts or strategies are pointing out the acting corridor.

Cottbus presented that kind of strategy within their concept “Cottbus 2020 - mit Energie in die Zukunft”. The Lausitz is and has been an energy region. Therefore it is not surprising that Cottbus mentions the goal of becoming a competence center of the energy sector and related industries.

III. SMART GRID AS A CENTRAL COMPONENT OF A SMART CITY

Energy is one of the fundamental factors in the city of the future as well as for fighting against the climate change. The implementation of increasing shares of renewable energies leads to a shift from centralized electricity systems towards a more decentralized power supply. This goes along with an intensified use of the lower voltage levels for the feed-in as well as an enhanced fluctuation in the energy supply. At the same time, the energy demand is growing.

To cope with the challenges of this transformation, the way of managing and using the electricity has to be developed. In the past, power was mainly made available by central fossil power plants that were able to accommodate the consumer's demand. Moreover caused by the increasing share of hardly predictable renewable energy sources, mainly wind and solar energy, the energy consumption and distribution has to be rethought.

A promising way to deal with these new challenges is the implementation of a Smart Grid. This intelligent energy networks interconnects and controls the energy suppliers with the consumers as well as with power supply utilities, storage facilities and the different voltage levels of the electricity network itself. This Smart Grid, equipped with highly complex information and communication systems, is able to monitor and optimize all components of the network.

One main benefit of renewables is, that once installed, they have very small variable production costs. This leads to a situation, where the price range on the electricity market increases, even making negative electricity prices possible in times of high energy supply by renewables accompanied by a low energy consumption. To let consumers take advantage of this cheap electricity and to increase the use of energy especially in times of high production, Smart Grids support them using software to integrate needs and wants in an efficient way.

A big problem with a higher share of renewable energies, especially in areas with unstable wind and solar irradiance, is to deal with the oversupply in times of high production. It is still very expensive to install a necessary amount of storage solutions. Another way to manage the surplus, especially in times where the electricity demand is typically low is to shift more consumption to these periods. Therefore the rigid tariff system in power supply should be extended by new schemes.

One example of such an innovative approach to sell energy is the Austria based electricity provider aWattar. It offers special contracts in combination with Smart Meters to let the consumer take advantage of low prices in times of high energy production. The prices are calculated in hourly time frames and handed down to the client. The Smart Meter performs two tasks at the same time. It measures the energy consumption of the household to make accounting possible despite constantly changing prices and it automates some of the tools in the house. Therefore prices can be pre-set so that for example a washing machine will start automatically when electricity is cheap. Furthermore aWattar provides his clients with information about regularities to plan the use of energy intensive tools or charge energy accumulators. It even combines all this services with a solution called SYNCER to run a thermal pump automatically and thus very efficient. To make sure, that the investment in the Smart Meter pays off, no hourly price will be more than 10% higher than the price of the monthly tariff.

Another concept is currently developed in Cottbus by IBAR, a company for system technologies. The idea deals with the implementation of gas and water supply as well as district heating to an automated system with variable tariffs. Main goal is to build a regional market that supports the idea of a decentralized island solution. Besides all this benefits, that could lead to power-to-heat solutions for the storage of surplus energy in times of high production.

Smart Grids in combination with variable storages and electricity tariffs can lead to a better alignment of energy supply and demand, making reductions in the conventional power park possible while making a better use of the energy provided by renewables like wind and sun. Furthermore, concepts and solutions like the ones of IBAR and aWattar bring a spot market-like tool to the consumer, giving them the opportunity to participate from the benefits of renewable energies.

IV. CAN COTTBUS BE A SMART CITY?

Besides the turn-away from fossil energy sources, that hits Cottbus and its economy hard, this city has to cope with the challenges of an aging population and young people leaving the region. So aspiring to be a Smart City could mean so even more for Cottbus than just taking the next step in the German energy transition. Cottbus could take the lead in an endeavour to face the challenges of the future, and in doing so creating economic income and providing new job opportunities for its people.

The potential to go this way is there. Situated in Brandenburg, the self-proclaimed energy state and being the heart of the energy county Lusatia (Lausitz), Cottbus combines experience in the energy sector with the determination to reinvent itself and develop in a sustainable direction. Furthermore, aspects of the Smart City are already part of the City Development Concept.

With the Brandenburg University of Technology Cottbus - Senftenberg there is a scientific institution that is focused on energy and the related fields of interest. With partners such as the Vattenfall AG and German e-Cars, new concepts of storage and bidirectional energy flow are researched, an area essential for the integration of e-mobility to Smart Grids. In a follow-up project called Smart Capital Region, the focus is now on the development of a solution for the island operation capability. The self-contained grid will first contain the university campus and its electrical relevant facilities and is scalable to serve for regional concepts as well as for big cities.

Besides e-mobility, also the conventional traffic sector plays its part to achieve sustainable solutions for the city. The existing traffic management system was renewed to cope with noise protection as well as reducing the environmental impact of the cars in the city center. To achieve this, traffic flow as well as emissions and driving behaviour were analysed by a company in Dresden and the results implemented in the concept. To top off the efforts in the mobility sector, the

public transportation is being optimized to cover the needs of the demographically changing population. In addition, electric busses are tested and the increased use of bicycles is supported through a network of appropriate bicycle paths. Most of these efforts not only target the reduction of greenhouse gas emissions, but also serve to decrease the noise level and with that increasing the quality of life in the city.

In a medium-sized city like Cottbus, trade and industry as well as resident enterprises are working hand in hand with politics and public administration. This enables short official channels and helps developing sustainable solutions with all partners relatively fast. That way different aspects of the Smart City are covered already with more to be implemented. In the near future, the various aspects are to be combined to an overall solution to secure the long-term success of the energy region with Cottbus in its center.

- [1] G7 Germany (2015): Leaders' Declaration G7 Summit, 7-8 June 2015, in http://www.bundesregierung.de/Content/DE/_Anlagen/G8_G20/2015-06-08-g7-abschluss-eng.pdf?__blob=publicationFile&v=5 (2015/06/20).
- [2] Libreria Editrice Vaticana (2015): Encyclical Letter LAUDATO SI' of the Holy Father Francis on care for our common home, in http://w2.vatican.va/content/francesco/en/encyclicals/documents/papa-francesco_20150524_enciclica-laudato-si.html (2015/06/20).
- [3] Deutscher Städtetag (2015): Wachsendes Gefälle zwischen den Städten – Entwicklungschancen für alle sichern, in http://www.staedtetag.de/imperia/md/content/dst/presse/2015/hv_dresdner_erklaerung_20150611.pdf (2015/06/20).
- [4] Wiener Stadtwerke (2011): Smart City: Begriff, Charakteristika und Beispiele, in http://www.nachhaltigkeit.wienerstadtwerke.at/fileadmin/user_upload/Downloadbereich/WSTW2011_Smart_City-Begriff_Charakteristika_und_Beispiele.pdf (2015/06/20)
- [5] Siemens (2010): Components of a Smart City, in http://siemens.cz-smartgrid.mass-php-1.mit.edu/cz-smartgrid/distribution/automation_and_protection.php?lang=en (2015/06/20).

Wind turbine machines onshore

Is it worth an investment of an investor?

Danny Mettke

BTU Cottbus-Senftenberg

Potsdamer Straße 1

03046 Cottbus, Germany

Danny.mettke@b-tu.de

Thomas Groß

BTU Cottbus-Senftenberg

Wolschinkastr. 2a

01968 Senftenberg, Germany

Thomas.groß@b-tu.de

Abstract— Nowadays the discussion is about regenerative energies very high. Germany wants to assume the position of a pioneer of electricity with renewable energies sources. This paper provides an overview of the situation in Germany and explains the technological background of wind turbine machines, the promotion and its costs. Furthermore, the paper gives a conclusion about the economy from wind turbine technology.

Keywords – wind turbine machine, economy wind turbine, onshore

I. INTRODUCTION

The climate change based on forecasted parameters leads to increased efforts of climate protection. The carbon dioxide emissions and use of fossil burning must be reduced in the future years. To reach this aim it is necessary to develop renewable energy sources. By substituting fossil fuels into renewable energy the greenhouse gas emission could be reduced. And also the power supply would be ensured. The foundation for these efforts has been created with inure of the renewable energy law. This law is based on political efforts of the government and it has also the intention of creating a new way of sustainable energy supply.

II. TECHNICAL BASES FOR WIND GENERATION

The renewable energy sources are important for the security of ecologically friendly energy supply. The global energy reserves are nearly unlimited, cost-effective comparing to fossil burning. Also the technical developments over the last decades are important indicators to promote renewable energies. Due to decisions on climate conferences and the need of reducing constant dioxide emissions the research and studies of environmentally friendly energy is urgent and essential [1]. Because of the almost unlimited availability, wind is a suitable and useful energy source [2].

The kinetic energy of wind will be withdrawn. Due to the rotor the wind energy will be converted into mechanical energy. With the use of a generator the mechanical energy will be converted into electrical power [3]. According to the physicist Betz, you can reach 59.3 % of the maximum effective

output or useable power [4]. In summary, following formula is given for using effective power:

$$P = 0.5 * \rho * A * (v^3) * \eta \quad (1)$$

Due to this formula, other facts will be clearly. On one hand, the power is depending on the wind speed. On the other hand, wind power station will be influenced by the circular area (A) of the rotor. Therefore, with an increased rotor diameter, the amount of available wind flow will also be raised, which will be transformed into electrical energy [6]. Nowadays are the height of a wind turbine by average 115 meters above sea level and an average diameter of 93 meters in Germany [7].

The height is important for the power of the wind turbine, because with an increasing height the wind speed will be higher too [8]. The reason is the roughness of the ground, which will be observed by the surrounding objects. If more objects are on the same level, then they will more slow down the wind. Therefore you won't get much power. Over the last years, the development of wind power station has been continued. Portfolio of German wind power stations has an average power of 2.3 MW. The highest power of a wind turbine is 7.5 MW [9] (see figure 1).

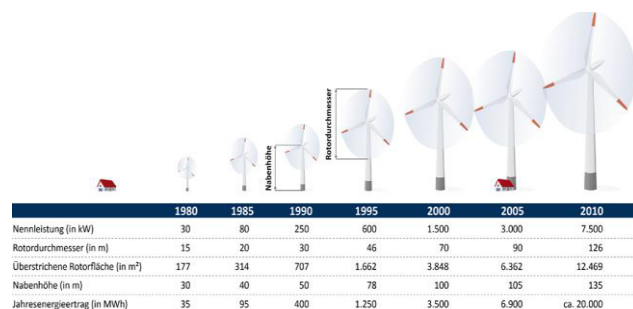

Fig. 1 Development of wind power station in Germany

III. PROMOTION TO PROVIDE RENEWABLE ENERGY ACT OF WIND POWER

After the technical circumstances of this kind of renewable energy have been discussed, the following phase will give you an overview of the financial promotion. The purpose of this

law is to promote the development of renewable energy sources and to create a competition against conventional powerhouses [11].

Plant operator have been a priority feeding of bulk current injection. Plant operator obliged to direct marketing. The difference between the stock exchange rate of electricity and the individual remuneration rate can be defined as the assured market premium. Precondition of the assured market premium is the remote control capability of the system (§ 35 EEG). Regarding to the promotion you need to make difference between the increased initial rate (8,90 cent/kWh) and the basic rate (4,95 cent/kWh). The claim of increased initial rate is valid at least 5 years to a maximum of 20 years (§ 49 EEG). This corresponds with the useful life of the plant. Because of different wind speeds and wind frequencies, you need to define parameters that create and guarantees equal opportunities for each location [6]. These are defined as (§49 Appendix 2 EEG):

- Average wind speed 5.5 m/s
- Reference height 30 m
- Roughness length 0.1 m

With these parameters you are able to determine the energy yield after 5 years. The energy yield has to be compared with the actual values. Then you'll get the result of the term for the increased rate. This determination is essential for the creation of incentives and also for limiting the construction of wind turbines. Based on the difference of wind speed at the location you'll get percentages. These terms determines the quality of location. For the calculation of the duration you need to use the stage model. The first stage is limited by a yield value between 100 – 150 % (see formula 1). The second stage applies by 60 – 100 % (see formula 2, § 49 Abs. 2 EEG).

$$T = 60t + \frac{(1.3R - E) * t}{0.36} \quad (2)$$

$$T = 60t + \frac{(1.3R - E)*t}{0.36} + \frac{(R - E)*t}{0.48} \quad (3)$$

- T ... time of promotion
- t ... month
- R ... reference value
- E ... earning value

Due to this stage model you are able to adjust the imbalance of strong- and los wind locations [13].

IV. COST OF A WIND TURBINE

To be able to make a statement about the economic efficiency and profitability of an onshore wind turbine, information about the investment volume must be available, including all costs incurred from planning to implement a project to the operationally finished installation of a wind turbine [14]. Those can be divided into major and minor investment costs. In addition, costs are incurred in operating the plant, which will be named as operating costs [15]. The main investment includes the purchase of a wind turbine: Amongst those are the main components of the tower, nacelle and rotor blades, whilst in some literature also installation costs

are taken into account [16]. A precise statement of these main costs is not possible, because each plant is individual in terms of performance, hub height and the rotor diameter. In range of 2 to 3 MW the costs range between 1183 €/kW and 1609 €/kW [12].

It is not enough to consider only the purchase of a wind power station. Indeed, there are further costs such as the site development, grid connection, the foundation laying and approval procedures. This is only an extract of possible side investments of a wind turbine [12]. The costs can differ substantially. The foundation laying may have different costs, because it depends on the soil conditions and size of the plant. Further, the grid connection is a critical issue, especially the distance to technically favorable tie points (§8Abs.1 EEG). In addition, the costs could increase if a wind farm is built and an internal wiring is needed. Adding these factors and the investment costs, the overall price can range between 159 €/kW to 529 €/kW [12].

Now all the costs from planning till commissioning of a wind turbine on land have been described. The total investment amounts from 1,342 €/kW to 2,138 €/kW. Still, the operating costs of the plant have to be considered. According to a report of experiences of the EEG the operating costs account for an average between 1.17 and 4.3 cents/kWh. There should be paid attention that are divided into two decades. It is assumed that there is a greater need for reparations within the second decade, caused by the operation and the resulting wearing off. These amount from 1.69 to 4.5 cents/kWh [12]. The variation in operating costs are derived from the differentiation regarding the maintenance. When buying a plant some equipment manufacturers also offer a service for maintenance. In contrast, others repair damages on their own [13].

Finally, the financing has to be explained. This is made up of equity and debt capital. The debt capital will be provided by the KfW- Bank available under a reduced rate in order to promote the expansion of renewable energy sources. It amounts between 1.46 % to 8.08 % [18]. The deviation can be explained by the financial standing of the company or investor. Finally, the Bank is keen on securing repayment of the loan. According to the EEG Progress Report, the average rate of a loan 4.01 %, which was considered in the subsequent calculation [12].

After all the facts and data regarding the costs and revenues were gathered, this part is for the assessment of the lucrativeness of the investment project. To obtain the resulting inflows and outflows a plant type and plant system rating has to be defined. This example deals with the plant N90 from Nordex Energy GmbH with an output of 2300 kW, which corresponds to the average wind turbine capacity in Germany since EEG Introduction [7].

V. PROFITABILITY OF A WIND TURBINE

At the reference site the N90 can produce a reference yield of 29,213,984 kWh within 5 years [19]. With this assumption, the individual full-load hours could be considered for the quality of the site. Now, when all factors are considered of

minimal to maximal costs and quality of the location, the following results emerge (see figure 2).

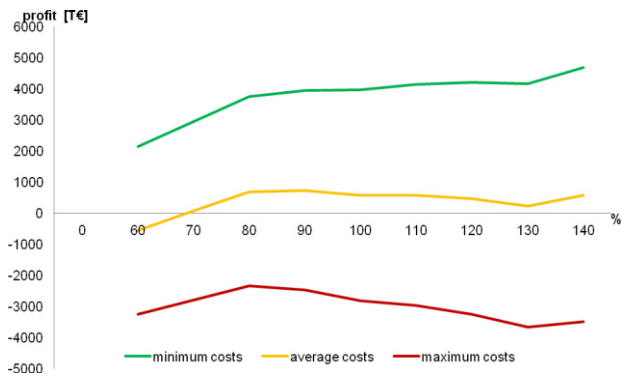

Fig. 2 economics of wind turbines depending on the quality of location

From the figure a statement about the profitability of the investment can be taken. The presence of minimum and average costs can all be seen as positive results (except in the presence of a 60 % Location Quality). Maximum costs display no gains after the offsetting with the new EEG. It should be noted that survey results were used for this analysis and no differentiation was made as to whether these are older plants, which are subject to an older EEG reform and underlie a different rate of remuneration. Therefore, the result of the maximum cost should receive a low priority. Furthermore the graphic shows that there are no strong differences between the profits of the various location qualities. For this reason, with the current law situation it is still attractive for investors to build a wind turbine on a site of inferior quality.

VI. CONCLUSION

The results listed in Chapter 5 are showing that the construction of an on shore wind turbine may be lucrative under certain conditions. If the costs are reduced to a minimum, the capital invested by the company or investors can be almost doubled. Furthermore, other factors could affect the results in a positive and negative way. There is no optimal usage of equity and debt capital, but rather limited to a period of 10 years. Furthermore a statement in literature cannot be found, whether a wind turbine could be operated for more than 20 years or not. Alternatively, an investor could sell the wind turbine after the increased initial tariff. The value of a wind power plant could not be determined. In addition, the operators of an installation are committed to direct marketing. In case of the market price is higher than the EEG remuneration, the operator does not have to repay, which would have a positive impact on the result. For this reason, investment projects are indeed risky, however, the chance to win after 20 years is quite high.

REFERENCES

- [1] Bundesministerium für Umwelt, Naturschutz, Bau und Reaktorsicherheit, „Nationale Klimapolitik“, on the internet <http://www.bmub.bund.de/themen/klima-energie/klimaschutz/nationale-klimapolitik/>, 2014 [19.06.2015].
- [2] Bundesverband Erneuerbare Energien e.V., „Windenergie“, on the internet <http://www.bee-ev.de/erneuerbare-energien/windkraft/> [19.06.2015].
- [3] Bundesverband WindEnergie, „Funktionsweise“, on the internet <https://www.wind-energie.de/themen/technik/funktionsweise>, [19.06.2015].
- [4] Gasch, R.; Twele J., „Windkraftanlagen, Grundlagen, Entwurf, Planung und Betrieb“, Springer Verlag, Wiesbaden, 2013, p.32.
- [5] Unger, J.; Hurtado, A., „Alternative Energietechnik“, Springer Verlag Wiesbaden, 2014, pp. 27-33.
- [6] Fraunhofer Institut, „Entwicklung der Windenergie in Deutschland“, on the internet http://www.agora-energiewende.de/fileadmin/downloads/publikationen/Agora_Kurzstudie_Entwicklung_der_Windenergie_in_Deutschland_web.pdf, 2013, S.6-21 [12.05.15].
- [7] Fraunhofer Institut, „Durchschnittliche Leistung neu errichteter Windenergieanlagen“, on the internet http://www.windmonitor.de/windmonitor_de/bilder_javascript.html?db_communicate=%27Windenergieeinspeisung.daten%27&p_lang=ger&img_id=405, o.J., pp.6-7 [19.06.15].
- [8] Internationales Wirtschaftsforum Regenerative Energien, „Wind: Windverhältnisse, Windgeschwindigkeit, Windgutachten, Windindex“, on the internet <http://www.iwr.de/wind/klima/> [19.06.15].
- [9] Landanstalt für Umwelt, Messungen und Naturschutz Baden-Württemberg, „Einführung“, on the internet http://www.lubw.baden-wuerttemberg.de/servlet/is/223148/BWE_Leistungssteigerung_910px.png [19.06.15].
- [10] Deutscher Bundestag, „Umweltbericht 2002, Bericht über die Umweltpolitik der 14. Legislaturperiode“, on the internet <http://dipbt.bundestag.de/doc/btd/14/087/1408755.pdf>, 2002 [19.06.2015].
- [11] Bundesministerium für Wirtschaft und Energie, „Erneuerbare-Energien-Gesetz 2014 (EEG 2014)“, on the internet http://www.erneuerbare-energien.de/EE/Redaktion/DE/Dossier/eeg.html?cms_docId=73930, 2014 [19.06.15].
- [12] Leipziger Institut für Energie, „Vorbereitung und Begleitung der Erstellung des Erfahrungsberichts 2014 gemäß § 65 EEG“, on the internet <https://www.bmwi.de/BMWi/Redaktion/PDF/XYZ/zwischenbericht-vorhaben-2e,property=pdf,bereich=bmwi2012,sprache=de,rwb=true.pdf>, 2014, pp. 46-163 [19.06.15] (46-163).
- [13] Dağaşan, P.; Schulz, S.; Trockel, S., „Das neue EEG 2014 - Was ändert sich?“, on the internet http://www.energieialog.nrw.de/das-neue-ee-2014-was-aendert-sich/#nderungen_fr_die_Windenergie_an_Land, 2014 [19.06.15].
- [14] Prognos, Fichtner, „Kostensenkungspotentiale der Offshore-Windenergie in Deutschland“, on the internet http://www.prognos.com/uploads/tx_atwpubdb/130822_Prognos_Fichtner_Studie_Offshore-Wind_Lang_de.pdf, 2013, p.38, [19.06.15].
- [15] Fraunhofer Institut, „Windenergie Report Deutschland 2013“, on the internet <http://publica.fraunhofer.de/eprints/urn:nbn:de:0011-n-283735-27.pdf>, 2013, p.40 [19.06.15].
- [16] Deutsche Windguard, „Kostensituation der Windenergie an Land, Internationaler Vergleich“, on the internet http://www.windguard.de/_Resources/Persistent/80d4d53fe8cdeff21edc7b0d4de1bfcf2e5e18cf/2014-04-03-Kostensituation-der-Windenergie-an-Land-intlA3-FinalReport.pdf, 2014, p.9 [19.06.15].
- [17] Hau, E., „Windkraftanlagen, Grundlagen, Technik, Einsatz, Wirtschaftlichkeit“, 5. Auflage, Springer, Berlin Heidelberg, 2014, p. 896.
- [18] Kreditanstalt für Wiederaufbau, „Merkblatt, Risikogerechtes Zinssystem“, on the internet https://www.ifbh.de/fileadmin/pdf/IFB_Download/IFB_Wirtschaft/17_Risikogerechtes_Zinssystem.pdf, [19.06.15].
- [19] Fördergesellschaft Windenergie und andere Erneuerbare Energien, „Veröffentlichung der Referenzerträge Nordex“, on the internet http://www.wind-fgw.de/pdf/Ref_Nordex.pdf, p. 2-4 [19.06.15].

The Solar Flight Around the World

The history and construction of Solar-Impulse

Michal Jackowski, Matthias Scheffel, Michael Rohloff

Masterstudium

Studiengang: Maschinenbau

Fachrichtung: Triebwerkstechnik

BTU Cottbus

Abstract — History and build of solar powered aircraft. In year 2015 after about twelve years of preparation two founders of company decided to take a round world flight only thanks to solar energy. As the pilots are in the middle of travel there is assumed to introduce the origin of the project. The main aim of both entrepreneurs is to show the people how far can take us the present engineering technology and development of renewable energy.

Keywords—solar energy; solar impulse; renewable energy; solar cells; aircraft engineering

I. INTRODUCTION

Taking a long distances in short period of time is no problem anymore. Already known is, that every action creates reaction so with big travels we used to pay for that with energy released from combustion of the fossil fuels. This process causes for example oxidation of hydrocarbon and nitrogen what in result harm the natural environment and people. Humanity is capable to obtain the energy from renewable sources like wind or sun. We used to see wind turbines and solar cells on fields but until now no one saw the possibility of taking this kind of energy to propel the aircraft and fly around the world.

Solar cells have definitely influenced the organization of electrical energy but they were not obviously built for getting machines flying. For about twelve years two men with a team of engineers design, build and test the Solar Impulse – first aircraft, that flies propelled by solar energy. There have been made tests already that took this machine into sky for about twenty four hours. Success continues and in this year is possible to see travel around the world.

II. HISTORY OF SOLAR IMPULSE

The idea of built such a plane which is driven only by electrical energy from solar cells was born in Switzerland. Bertrand Piccard and André Borschberg are founders of company and whole event. In result they had assumed to fly by themselves around the world without drop a fuel.

In 2003 there was an official beginning of Solar Impulse Project in cooperation with Technical University in Lausanne. This university have taken the main task of development the structure and materials needed to build the airplane. As the project grown there was more companies and institutes

interested in taking part in design process. The European Space Agency took part in evolving solar cells needed as main source of energy for electrical motors.

As the project was gaining in popularity and publicity in media and internet of using renewable energy for propelling aircraft, there have been found new sponsors to get the idea real.

The first fly of Solar Impulse took place in December 2009. That was short fly with distance of four hundred meters and one meter above the ground. The next test was in year 2010, where the machine flew at the high of thousand meters and whole flight last for about eighty seven minutes. A few months later there was another attempt but this time the Solar Impulse team decided to test the machine at the night. The control of aircraft took one of the entrepreneurs André Borschberg, which has succeeded with constant flight for twenty six hours at the altitude of about nine thousand meters above the ground. An average flight was forty kilometers per hour. Success has continued and the aircraft has flown its first international flight to Brussels. The first flight over the continent was in USA in year 2013. Over a month took to cover a distance from California at the west coast to New York at the west coast

In the year 2015 the team decided to organize a round the world trip without a drop of fuel. It is already started in March from Abu Dhabi, where the aircraft is supposed to back after flight around the world. The pilots are both of entrepreneurs, they decided to divide this trip with intervals of five days. So besides the technical ability of aircraft, the biggest boundary is human. In order to save the weight, Solar Impulse has a non-pressurized cabin, so the pilot should always fly in masks with oxygen. Also there would be a big gradient of ambient temperature from minus forty to plus forty degrees Celsius. The most important thing is rest of the pilots. They decided to sleep only for about twenty minutes in intervals for whole five days in order to give the brain appropriate rest.

At this moment the Solar Impulse is going to achieve city of Nagoya in Japan.

III. CONSTRUCTION

Solar Impulse has two version. The first one was designed as a demonstration aircraft. It has a non-pressurized cockpit and whole aerodynamic lift is produced by a single wingspan that reaches length for about sixty four meters. The main power

source comes from photovoltaic cells mounted on wing and upper surface of the horizontal stabilizer. The whole number of them is eleven thousand and six hundred twenty eight. They produce two hundred and fifty Watts of energy on every squared meter. The total weight of solar cells themselves is four hundred kilo grams. Such big wingspan in case of turbulences is susceptible to various of stresses such as torsion and bending. In design process engineers had to trouble with this task in order to keep the photovoltaic source of energy in one piece because they are direct attached to wing. There was designed special construction in order to separate transfer of stresses from the structure to solar cells.

Solar Impulse has to possess the possible small weight. It is mainly built from composites materials such as carbon fibre with honeycomb sandwich structure. In case of aircraft construction there are faked loads such as landing gear, which is important only by start and landing procedure but it's weight has to be carried throughout whole flight. The landing gear of Solar Impulse is maximal reduced in weight and complexity in order to avoid redundant forces during flight. The total mass is equal to twenty five kilo grams. Although the whole construction by takeoff maximal weight is about two tons.

Fig. 1. Construcion of wing



In the Fig. 1. there shown a method of connecting the photovoltaic cells to the wing.

The thrust force for the aircraft is produced by four electrical engines. Each of them provides seven and half kilo Wats of energy what corresponds to ten horse power. Every engine is supported by lithium-ion-battery, which deliver twenty one kilowatt-hour of electrical energy. The total weight of batteries is four hundred and fifty kilo grams, what is about one fourth of loaded weight of the aircraft. The Solar Impulse is capable to reach the cruise speed of seventy kilometers per hour.

After reaching the satisfying results in first version of solar powered aircraft, the team have improved performance and called the new airplane with name Solar Impulse 2. The wingspan is comparable to one of the biggest civil aircraft Boeing 747, what allows increase the number of solar cells. Cruise speed has grown thanks to new powerplant, which enables to deliver more power.

REFERENCES

- [1] www.solarimpulse.com

Passive houses

building of the future really efficient?

Joanna Paradowska
BTU Cottbus-Senftenberg
Cottbus, Germany
asiaparadowska@interia.pl

Mateusz Czasnoję
BTU Cottbus- Senftenberg
Cottbus, Germany
matekczas@gmail.com

I. What is passive house?

A term passive house refers to a building that does not use normal heating. The thermal comfort must be guaranteed without an active heating system in winter and no air conditioning in summer. Such a house is the further development of low-energy house, which is mainly heated by solar radiation and internal heat gain. A passive house has extremely increased thermal insulation and an absolute air tightness. A house can be called a passive house, if it meets the following criteria:

- ✓ the annual heating demand (Q_h) cannot exceed 15 kWh/m²
- ✓ the annual primary energy use (Q_p) must be less than 120 kWh/ m²
- ✓ the thermal transmittance coefficient (U-values) of the building components must comply with an increased thermal insulation
- ✓ the air changes per hour (n₅₀) at a differential pressure of 50 Pascal must be less than 0,6h⁻¹
- ✓ the triple-glazed, noble gas-filled thermal-insulation-windows with insulated frames must be provided

II. Principles of construction

By designing of passive house planner must follow many principles of construction. The most important are:

- ✓ orientation of the building: the main façade should be oriented to the south, so that large solar heat gain can be obtained. Moreover, the building must be protected from the wind and have a natural shading of windows of the south facades.
- ✓ compactness: the possibly smallest ratio of surface to volume reduces the heat loss in the building and it should be between 0,4 – 0,7. The best shapes are: square, circle, octagon or ellipse.
- ✓ highly insulated building envelope: the thermal insulation of all building components must be placed without gaps and the thickness of the insulation should be between 25 and 40 cm. The existing thermal bridges (areas through which the heat is transported to the outside faster) are to be minimized thereby.

- ✓ air tightness: the building must have a total heated volume of the comprehensive, continuous and airtight envelope.
- ✓ appropriate ventilation: in a passive house it would be the best to install a mechanical ventilation system with a high-efficient waste heat recovery.

III. Building technology in the passive house

In a passive house various systems for heating and ventilation can be installed. First option is to separate ventilation system and water heating. In this case hot water preparation must be necessarily carried out with the solar system.

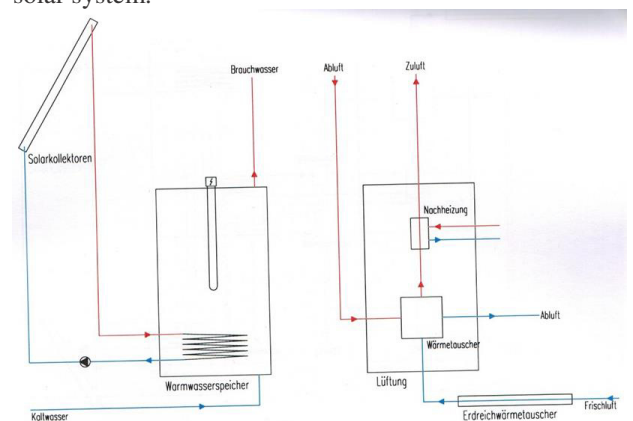

Diagram 1: separate ventilation and water heating system
Source: D.Siegele, Passivhaus: Das Bauen der Zukunft, Books of Demand GmbH, Norderstedt, 2006

Another option is to build up a system with the heat pump. The heat pump is used to heat the air and at the same time to hot water preparation, although during the sunny days water is heated with a solar energy system.

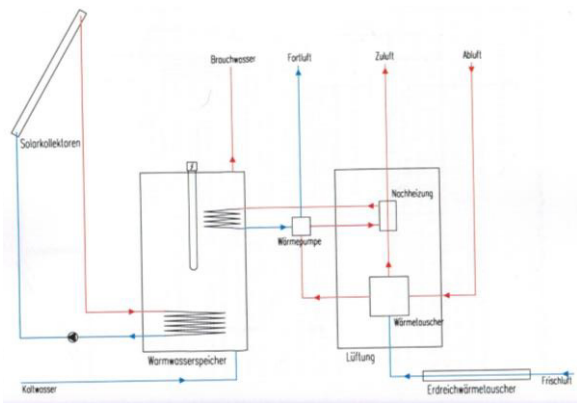

Diagram 2: system with the heat pump
 Source: D.Siegele, Passivhaus: Das Bauen der Zukunft, Books of Demand GmbH, Norderstedt, 2006

The next solution is to build up a system with the heat accumulator in this way that air and process water from this accumulator are being heated. The heat accumulator can be carried out either by means of solar energy system, heat pump, heating register or by means of and oil or gas heating. This system is very efficient, but also costly.

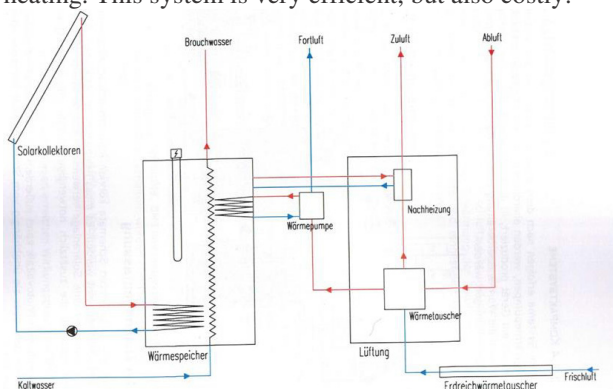

Diagram 3: system with the heat accumulator
 Source: D.Siegele, Passivhaus: Das Bauen der Zukunft, Books of Demand GmbH, Norderstedt, 2006

But most frequently installed is compact system that works with the same principle as the system with heat pumps. There is one device for ventilation and hot water preparation.

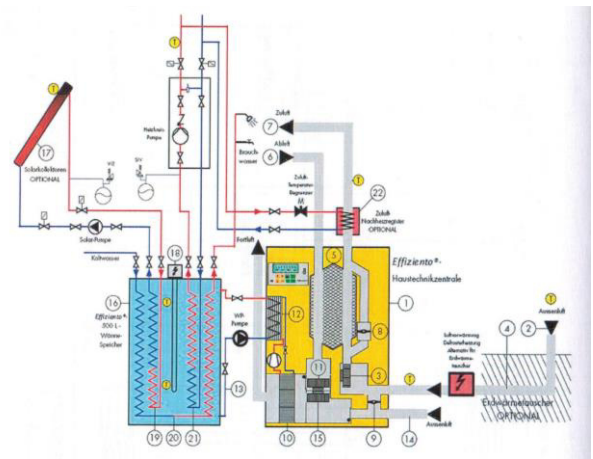

Diagram 4: compact system
 Source: D.Siegele, Passivhaus: Das Bauen der Zukunft, Books of Demand GmbH, Norderstedt, 2006

IV. Ventilation systems in passive houses

The ventilation allows continuous supply of fresh air and suction of odorous substances, CO₂ and used air. A person needs 30 m³ of fresh air per hour. High airtightness of a passive house limits the entry of fresh air (e.g. through the gaps), so the intake and exhaust air systems are required. Two of the most common ways are:

- ✓ ground-coupled heat exchanger – it consists mostly of plastic and concrete pipes or a brine pipeline (PVC cable) which are placed in the ground. In winter they are used to preheat the fresh air, so that the frost line of 4°C can be exceeded before the heat exchanger. In summer they are used as a cooling tunnel for the fresh air. At the end of the exchanger, a condensation drain should be provided (for easy cleaning). The total cable can be from 35 to 50 meters long and has to be laid at a depth of 1,2-1,5 meters.
- ✓ ventilation device – it is a central control for the fresh air and heating supply. Fresh outdoor air is heated in ventilation lines and the used room air is pumped into exhaust air ducts past the heat exchanger as exhaust air to the outside. Such a device must fulfill the following criteria: a supply air temperature above 16,5°C, a filter of class F7, specific electricity demand below 0,45 Wh/m³, efficient waste heat recovery above 75% and a sound pressure level below 35 dB.

V. Heating systems in passive houses

For heating in a passive house different ovens can be applied. Such a system is fully independent of the ventilation system and can be used as emergency heating. It can also be installed an electric post heating register, in which the electrical energy is converted directly into heat. Another option is to build up different floor-, wall- or ceiling-heating systems. The heat pumps are very well suited for this, because the supply temperatures are below 30°C and in this case the heat pumps generate the optimal performance number.

VI. (Economic) efficiency

Always when it comes to the energy efficient news, everyone wonders first of all about economic efficiency of investment. For each passive house different additional costs need to be expected. The design and planning phase are very expensive in this case: a particularly high-quality thermal insulation can cost about 5000 €, a necessary ventilation technology with waste heat recovery (centralized or decentralized) over 5000 €, very high insulating windows with triple thermal glazing nearly 6000 € and moreover costly detailed solutions for waterproof membrane and avoidance of thermal bridges need to be taken into consideration. On the other side there are reduced cost, like for example no gas connection, no oil tanks, no necessary technology for heating, no chimney flues in heat pumps, low maintenance costs of hot water and heating, no costs of gas meter und full independence from rising electricity prices (what altogether is approximately -1500 €). Investments are significantly higher, but the usage is cheaper and a passive house can be profitable even from the first day. Now there is still one question, namely how someone wants to finance the building of a passive house. In order to build an energy-saving passive house it is possible to take a cheaper loan. Considered over all this results in compensated and sometimes positive balance.

VII. Advantages of a passive house

- ✓ low heating costs
- ✓ independence of energy operating company, availability and price of fuels
- ✓ higher living comfort: nearly constant temperatures during the whole year and no draughts
- ✓ small differences between room and surface temperatures
- ✓ no noise pollution thanks to high quality of windows
- ✓ high air quality thanks to controlled living space ventilation
- ✓ high resale value
- ✓ active environment protection and less carbon dioxide emission
- ✓ longer durability of building components thanks to good air and moisture protection

VIII. Disadvantages of a passive house

- ✓ higher effort connected with the planning and execution
- ✓ high investment costs
- ✓ no variable temperatures in the house
- ✓ low relative air humidity in winter
- ✓ high costs of additional heating in case of incorrect execution of the air tight envelope
- ✓ for large thermal bridges increased heat use is possible

IX. Summary

When a passive house is being built the design phase is particularly important, all the details must be thoroughly considered and the aspects of thermal bridges and air tightness must be well planned. Planning and execution take a lot of money, but a passive house requires 90% less energy than conventional buildings that comply with relevant standards. In spite of a very high acquisition costs of a passive house, the reduced costs can be expected due to lower both energy and additional costs. The passive houses are developing all the time and there are being built also so called innovative passive houses, such as solar passive houses, zero-energy houses or solar plus energy houses.

- [1] D.Siegele, Passivhaus: Das Bauen der Zukunft, Books of Demand GmbH, Norderstedt, 2006, pp. 1-11,51-72.
- [2] A.Sommer, Passivhäuser: Planung-Konstruktion-Details-Beispiele, Rudolf Müller Verlag, Köln, 2008, pp. 19-28,109-150,279-286.
- [3] D.Pregizer, Grundlagen und Bau eines Passivhauses, 2nd ed., C.F.Müller Verlag, Heidelberg, 2007, pp. 1-3, 26-29, 31-34, 99-114.
- [4] W.Feist, Gestaltungsgrundlagen Passivhäuser, Das Beispiel Verlag, Darmstadt, 2001, pp. 5-14.
- [5] Ragonesi, Menti, Tschui and Humm, Minergie-P: Das Passivhaus nach Schweizer Art, 1st ed., Faktor Verlag, Zürich, 2008, pp. 8-9, 35-39.
- [6] C.Grobe, Passivhäuser planen und bauen, Verlag Georg W.Callwey, München, 2002, pp. 13-20, 52-77, 113-131.

Wind powered cars

Are these new perspectives a good solution to solve the energy problem?

Patrick Artur Hoidem
BTU Cottbus-Senftenberg
Cottbus, Germany
phoidem@b-tu.de

Krzysztof Konrad Janisiak
BTU Cottbus-Senftenberg
Cottbus, Germany
krzysztofkonrad.janisiak@b-tu.de

Abstract—Wind energy is quickly growing. The demand on conventional energy like oil, gas and petroleum is growing too. These extremely situation has forced to think about another options to counteract the fuel disappearance. One possibility to solve the problem is to find another energy sources, because not only the industrial sector depends on energy but also the vehicle. This paper concentrates on the discussing about new energy sources like wind-power for vehicles.

Keywords—shale wind; transport; energy; emission; external energy sources; generator; turbine;

I. INTRODUCTION

Motorization is a major consumer of energy and now almost entirely dependent on oil. Means of transport are currently the recipient of 25% of total world energy with the global value and it is doubled every 30 years. Sciences predict that road transport will increase by 2050 in the ratio of 1990 by 181%. The increase of the number of car users in the near future clearly shows the further development of the automotive industry and further increase in the consumption of energy from oil. It creates another problem of environmental pollution and forces new requirements for its protection. The combustion engine is the primary source of vehicles drive. During operation emits into the atmosphere different toxic compounds. The car company have started to modernize cars to reduce carbon dioxide emission in it. In 2050 increase in emission of 3x higher carbon dioxide, 30% nitrogen oxide and 70% sulfur dioxide. One way to solve the problem of petroleum depletion is to find alternative fuels that have no additional negative effects of burning would be new energy carriers for the motorization [1].

II. WIND-POWERED CARS

If we talk about the factors which influence on this issue, we can divide it into two groups. The first is connecting with people and the second not concerning human. The reason why we can't see any wind-powered cars on public roads is, that the process of harnessing with energy, converting it into electricity and distributing it to charging stations is too complicated and expensive at the moment. A lot of wind farms have to be build across the world, much more than there are now, because the amount of energy that is needed to power the millions of cars can't be generated at this moment. Building of a wind farm is very expensive. In addition wind is quite unpredictable and it's not always available or just not in the way we want it to be.

Sometimes it's strong, sometimes it's weak. It is depending on the season, weather conditions and regional patterns, what makes the thing complicated and we can't rely on it so much. Even if there were enough wind farms, distribution of wind power would still be a serious problem. Wind can drive an vehicle, but cannot be used as the only car "fuel", cannot be the primary source [2].

III. WIND TURBINES ON CARS ROOFS

We can find some information about car companies which invent new solutions in powered a car. On the Fig. 1 and Fig. 2 we can see that the car has a wind turbine on the roof. This scheme is a patent from Edward Deet (U.S. Patent No. 7,135,786).

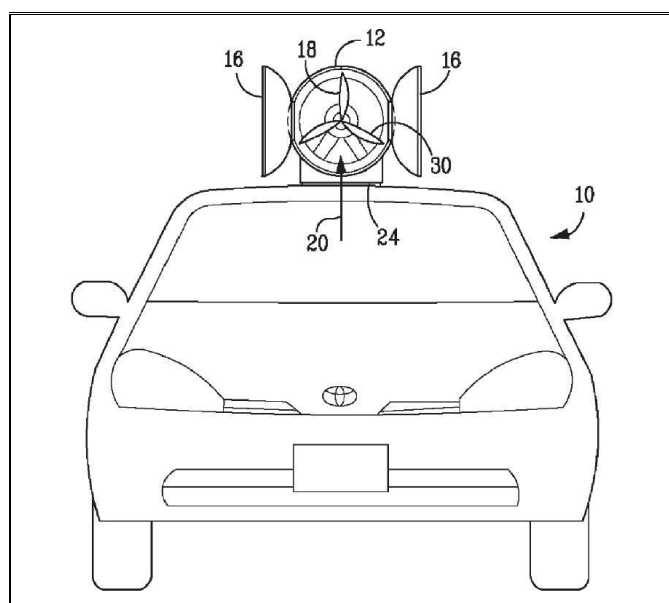

Figure 1. The car with wind turbines on the roof [3]

The generator is driven by wind and can use the power to charge the battery which runs the electric motor. The enclosure with controllable shrouds can open and close to channel air to the turbine. The rotational energy of the turbine causes an alternator or generator to generate electricity, which charges the storage battery. A regulator prevents overcharging of the battery [3].

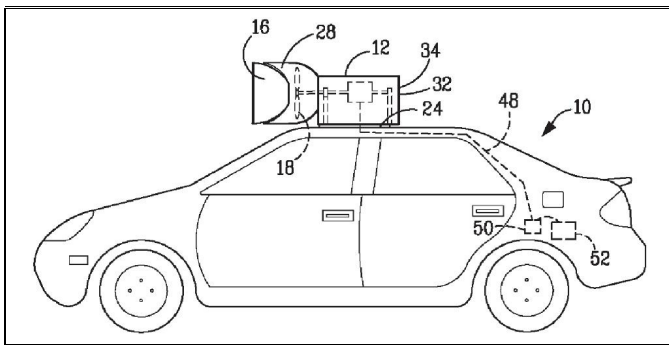

Figure 2. The car with wind turbines on the roof [3]

IV. TRAVEL UPWIND FASTER

Rick Cavallaro has developed in 2010 a wind-powered car called the Blackbird. The car is capable of traveling upwind at speeds faster than the wind. We can see this car on the Fig. 3. The team of Cavallaro set a world record by traveling downwind at 2.8 times the speed of the wind. Furthermore, they recently tweaked the vehicle to travel upwind as well. This car is made of foam, which makes it significant lightweight. Additionally the vehicle has an incredibly aerodynamic shape. It features modified bicycle wheels and a transmission that conveys power from the wheels to the large prop. The huge propeller turned by the car's wheels, that start moving once the wind starts pushing the car, propeller pushes the wind backwards, creating thrust, and car can moves forwards too. This achievement of driving upwind faster than the wind can be done by the synergy effect. The interaction of two factors that work together have a greater efficiency than if they acted alone [4].



Figure 3. The Blackbird [4]

V. WIND EXPLORER

Two brothers have constructed the Wind Explorer and have drove 5000km without using any external energy sources. We can see the wind explorer on the Fig. 4. It was done for the first time. The Car has been driven by wind energy and direct wind

as well. This small, lightweight car has four wheels and was able to traverse Australia. It was possible by using wind power to recharge its 8kWh lithium-ion battery pack by using a portable wind turbine. It's actually quite ingenious really, in the evening the turbine would be set up using a 20-ft telescopic bamboo mast and rotating fan blades to recharge the batteries. When the batteries were depleted the team has returned to using a kite. This was able to harness the wind and allowed them to speed up to 80km/h. The energy of 4kWh was enough to drive 200km [5].



Figure 4. Wind explorer [5]

VI. CONCLUSION

The technological progress will support us by inventing several solutions for driving the cars. In this report we tried to show that it is possible to use energy from the wind to power the vehicles and not only from the conventional resources. Actually people spend millions of dollars to solve the problem of obtaining the best fuel for cars, which will be out of toxic compounds, environmental friendly, commonly available and cheap. We will see in nearest future if this application, which we presented will be commonly use on our roads or maybe scientists with cooperation with the car companies will create something completely different. One fact is certain that we have to find solution to reduce CO2 emission in our cars and reduce our dependence of fossil fuels. Maybe one of this solutions could be the cars without any external energy sources.

REFERENCES

- [1] G. Jastrzebska, "Odnawialne zrodla energii I pojazdy proekologiczne," pp. 150-154, WNT 2007.
- [2] <http://auto.howstuffworks.com/power-all-cars-from-wind-power.htm/printable> Retrieved: 2015-06-18.
- [3] <http://www.greenpatentblog.com/2008/09/17/ford-to-explore-wind-turbines-on-car-roofs/> Retrieved: 2015-06-18.
- [4] <http://www.wired.com/2012/07/wind-powered-car-upwind/> Retrieved: 2015-06-18
- [5] <http://www.ridelust.com/wind-explorer-kite-car-crosses-australia/> Retrieved 2015-06-18

Renewable Energies

Biomass as an Energy Source

Alina Schiffer

BTU Cottbus-Senftenberg
Platz der Deutschen Einheit 1
03046 Cottbus, Germany
AlinaMaria.Schiffer@b-tu.de

Christina Jacob

BTU Cottbus-Senftenberg
Platz der Deutschen Einheit 1
03046 Cottbus, Germany
ChristinaSophie.Jacob@b-tu.de

Maximilian Kajkowski

BTU Cottbus-Senftenberg
Platz der Deutschen Einheit 1
03046 Cottbus, Germany
Maximilian.Kajkowski@b-tu.de

Abstract — Politics of today focus more and more on renewable energies. This trend can especially be observed in Germany and their reaction to the nuclear accident of Fukushima in 2011. Energy sources that allow the interaction between covering human needs and saving planet earth do exist. As an introduction to renewable energies this paper provides information on biomass as an energy source - biomass as a renewable and efficient energy source?

Keywords-biomass; renewable energy; biomass; energy source; biomass power plant, CO₂-cycle

I. INTRODUCTION

The electricity produced from renewable energy sources has grown in 2014. According to the German Association of Energy and Water Industries, it accounts for 25.8 percent of gross electricity generation in Germany. For the first time energies produced by renewables (sun, wind, biomass et cetera) surpassed the amount of energy produced from lignite. In past years lignite was the energy source with the highest share in the German power mix. The share of renewables in gross electricity consumption accounts in fact for 27.3 percent as Germany had exported electricity in 2014. The most important renewable energy source is wind energy with 8.4 percent share. Significant growth is expected in the next years. Photovoltaics were able to increase to a 5.8 percent share over the previous year, compared to 2013 with 4.7 percent. The share of biomass, 8.0 percent and hydropower, 3.4 percent remained stable. [1]

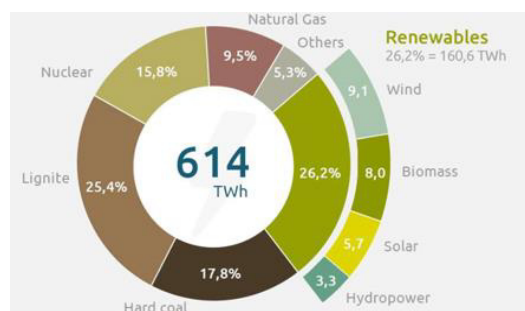

Figure 1 Germany's Energy Mix 2014 (Source [2])

In 2000 the growth of renewable energies in the electricity sector got greatly supported by the introduction of the EEG. Although the share of renewables in the German electricity mix has increased significantly in recent years, the major part of the electricity is generated by conventional power plants. The growth of renewables in 2014, has contributed to the decline in natural gas and coal. However the CO₂-intensive power generation with lignite is constant at a high level in long-term comparison. [3]

This paper focuses on biomass as an energy sources. In Germany, the production electricity with biomass is encouraged by the Renewable Energies Act (EEG).

II. FACTS ABOUT BIOMASS

Biomass is solar energy stored in plants. It is an energy source in the form of wood, straw, grasses, cereal crops and sugar or oil-bearing plants. But manure slurry and manure are also defined as bio waste, in the same way as sewage sludge and landfill gases. Biomass is inexhaustible, never ending energy source. Its annual formation on the planet exceeds the human needs for energy by five to six times. Unfortunately, only a part of the growing biomass can be actually utilized due to ecological, technical and economic reasons. However, it still has a huge potential. [4]

In Germany biomass as an energy source is going to contribute significantly to energy supply. It can potentially cover up to 23% of the demand for heat, electricity and fuel by 2050. So wood, energy crops, straw and biogas have the potential to generate some of our energy sustainably. In the future there is the possibility to import more biomass or sources derived from biomass. Compared to fossil fuels, there is a lower dependency on the supplier as there is a greater choice of supplier countries and no biomass scarcity. [5]

The application includes heat generation, cogeneration and fuel. The power range is from 1kW to 30MW. [6]

III. PROVIDING BIOMASS ENERGY

Biomass can be converted in very different supply chains of energy: in the form of heat, electricity, light. Beginning with

the land-intensive production of energy crops and providing of organic waste. The process continues with the production of fuel which is distinguished in 3 different paths: thermochemical, physical- chemical or biochemical conversion. The result is the production of solid, gaseous or liquid fuel. These three kinds of fuel are used to produce the final energy form of power, light and, or heat. The chain ends with the provision of the final energy. [7]

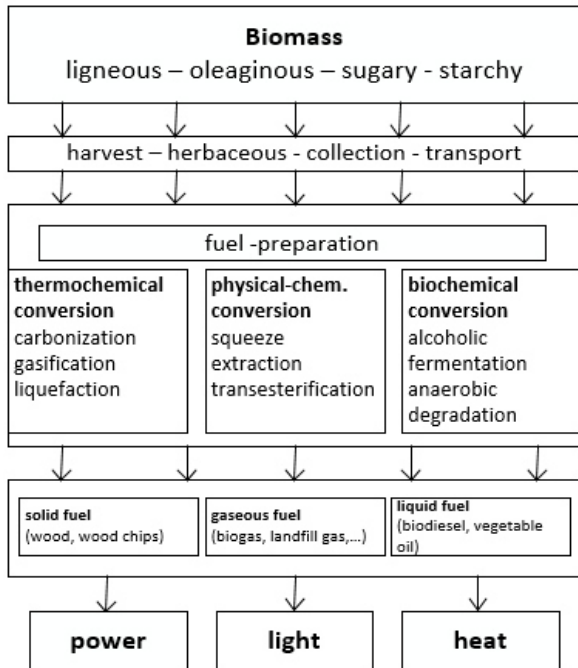

Figure 2 Providing Biomass Energy (Source adapted from [8])

IV. ELECTRICITY GENERATION FROM BIOMASS 2014

Like you can see in table 1, the development of electricity generated from biomass in Germany got more and more important in recent years.

	Market Share in Mrd. kWh	Market Share in %
2012	44,6	7,45
2013	47,9	8,0
2014	49,1	8,2

Table 1 Market Share of Biomass in Germany 2012 to 2014 (Source [9])

In 2014 around 49.1 TWh of bioenergy were generated, whereby biogas and solid biomass contributed 59.1% and 24.2% respectively, to the total amount of electricity generation. The most important kind of biomass is wood, a local raw material. For example, up to 6-8 million cubic meters of new wood are growing in Bavaria each year. If we use biomass in a sustainable and efficient way, it has the potential to replace fossil resources. [10]

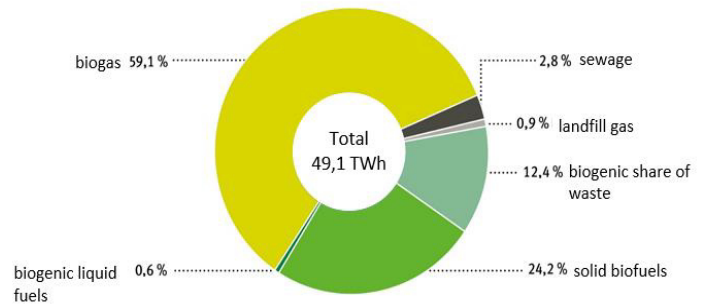

Figure 3 Electricity generation from biomass 2014 (Source [11])

V. BIOMASS POWER PLANTS IN GERMANY

There are 95 biomass power plants located in Germany which are divided in three different groups regarding its output. The first category is power plants of less than 5 MW. The second group has an output between 5-19 MW and the third group an output of more than 19 MW. In the neighbourhood of Cottbus, there are two biomass power plants. One biomass power plant is located in Spremberg (Sellessen). It is operated by Vattenfall Europe AG (Society of mining and construction machinery) and has the capacity to produce 2.8 MW of electricity per year. The second biomass power plant and one of the biggest biomass power plants in Germany is located in Berlin-Rudow. It is operated by WE Innogy Cogen GmbH and has the capacity to produce more than 20 MW of electricity and 65 MW of thermal power per year. [12]

VI. BIOMASS COMBINED HEAD AND POWER STATION

A biomass power plant is a power plant that generates electricity and/or heat by burning of solid, liquid and gaseous biomass. The process starts with the transport of biomass close to the combustion chamber of the power plant.

A. Methods to burn the Biomass

There are two different methods to burn biomass. First the grate boiler process and second the fluidized bed boiler process.

a. GRATE BOILER PROCESS

The first method is the grate boiler process, in which the biomass is dried, ignited and burned on a grate in number of different zones.

b. FLUIDIZED BED BOILER PROCESS

The second method is the fluidized bed boiler process, in which the fuel goes directly into the combustion chamber. While light fuels burn easily and heavy fuel drops down into a sand layer, the incineration is homogenized and the fuel is held in suspension. Then air gets blown into the boiler floor in order to mix sand and fuel and to fluidize it. [13]

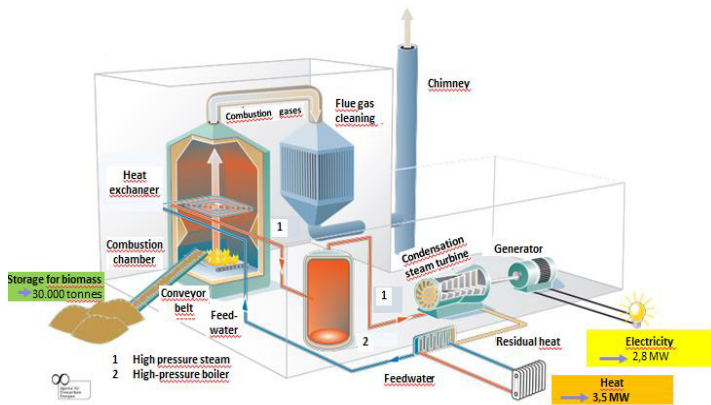

Figure 4 Expiration of a Biomass Power Plant (Source [14])

In both methods the flue gas passes through a flue tube. The tubes consist of tube coils, which act like evaporator and superheater surfaces. Afterwards the steam passes to turbines which are linked to a generator that generates electricity. If some of the remaining heat of the steam is used for local or district heating supply, the plant is called a biomass cogeneration plant. The flue gas gets cleaned carefully and emitted back to the environment.

But what makes biomass energy renewable? The answer lies within the CO₂ cycle. A huge amount of the CO₂ is released during the combustion of biomass. The burned biomass had previously bound CO₂ into their organic material through photosynthesis and new plants will absorb and bind CO₂ as well. According to that, the combustion of plants or fuels is largely balanced and is more sustainable than fossil fuels. [15]

VII. ADVANTAGES AND DISADVANTAGES OF BIOENERGY

The use of biomass as an energy source does not only provide advantages but also disadvantages.

Like it was mentioned in the previous chapter, biomass as an energy source is much easier to store than other renewable energy sources like wind or sun. Biomass has a positive CO₂ emission compared to conventional energy sources, mainly because biomass binds carbon dioxide during the growth through photosynthesis and it relieves our atmosphere. Additionally, the use of biomass as an energy source increases the regional value. This means it enables an additional source of income for forestry and agricultural business, because of the production of biomass. Thereby, it results in, both, the independence of imports due to its regional availability and the creation of regional jobs. Thanks to the technological advances, it is nowadays possible to burn biomass with extremely low emissions increasing the positive aspects of using the biomass as a new or additional energy source. [16]

Where there are advantages there are also mostly disadvantages.

A main disadvantage of biomass is the land needed in order to grow organic material. Therefore it leads to a conflict between planting biomass for energy and planting it for food, which is

a massive problem especially in developing countries. Furthermore, the ash of burned biomass leads to emissions, which would fall under special regulations and need to be cleaned in any case.

In order to keep the high efficiency of the modern power plants, there has to be a high maintenance. This includes high costs to keep the high efficiency. Biomass power plants spur local protests and citizens' initiatives because of their emissions and unpleasant odors (biogas) so that biomass power plants are considered to be a rather unattractive neighbor. [17]

VIII. CONCLUSION

Through the use of biomass as an energy source, every form of energy that is relevant to cover human needs can be produced. These contain electricity, heat, light and fuel.

According to experts in the field of biomass, up to the year 2050, nearly 23% of heat, fuel as well as electricity will be produced from biomass to cover human needs. [18] In order to achieve this, the usage of wood, energy crops, straw and biogas has to be highly sustainable. As it was mentioned in the previous chapter, biomass as an energy source has advantages as well as disadvantages which should not be forgotten.

REFERENCES

- [1] Agentur für Erneuerbare Energien, [http://stromreport.de/stromvergleich/#stromerzeugung](http://www.google.de/imgres?imgurl=http%3A%2F%2Fwww.unendlich-viel-energie.de%2Fmedia%2Fimage%2F5228.AEE_Strommix_Deutschland_2014_Dez14_Web_72dpi.jpg&imgrefurl=http%3A%2F%2Fwww.unendlich-viel-energie.de%2Fstrommix-deutschland-2014&h=494&w=600&tbid=rHm-BEaz7L65cM%3A&zoom=1&docid=n2hW0zsDEeziVM&ei=mUqdVb-fNEYPygYO_ioDwCw&tbm=isch&iact=rc&uact=3&dur=259&page=1&start=0&ndsp=24&ved=0CC0QrQMwBA, 2014
[2] Strom-Report, <a href=)
- [3] Agentur für Erneuerbare Energien, [http://www.wege-zum-bioenergie-dorf.de/wege-zum-bioenergie-dorf/biomasse-als-energetraeger/](http://www.google.de/imgres?imgurl=http%3A%2F%2Fwww.unendlich-viel-energie.de%2Fmedia%2Fimage%2F5228.AEE_Strommix_Deutschland_2014_Dez14_Web_72dpi.jpg&imgrefurl=http%3A%2F%2Fwww.unendlich-viel-energie.de%2Fstrommix-deutschland-2014&h=494&w=600&tbid=rHm-BEaz7L65cM%3A&zoom=1&docid=n2hW0zsDEeziVM&ei=mUqdVb-fNEYPygYO_ioDwCw&tbm=isch&iact=rc&uact=3&dur=259&page=1&start=0&ndsp=24&ved=0CC0QrQMwBA, 2014, [20.06.2015]
[4] Bundesministerium für Ernährung und Landwirtschaft, <a href=), 2014, [21.06.2015]
- [5] Fachagentur Nachwachsende Rohstoffe e.V.: [- 32 -](http://www.fnr.de/presse/pressemitteilungen/aktuelle-mitteilungen/aktuelle-nachricht/?tx_ttnews%5Byear%5D=2011&tx_ttnews%5Bmonth%5D=04&tx_ttnews%5Bday%5D=28&tx_ttnews%5Btt_news%5D=483&cHash=72fb9f40485c7d2cc1927cfc2aea67ab, 2011, [22.06.2015]
[6] M. Fishedick, O. Langniß, J. Nitsch, Nach dem Ausstieg, Zukunftskurs Erneuerbare Energien, Hirzel Verlag: Stuttgart, 2000
[7] H. Hartmann, K. Reisinger, K. Thüneke, A. Höldrich, P. Roßmann, Handbuch Bioenergie-Kleinanlagen, 2. Auflage, Stadtdruckerei Weidner: Rostock, 2007

</div>
<div data-bbox=)

- [8] Energielandschaft,
http://www.google.de/imgres?imgurl=http://www.energielandschaft.de/uploads/pics/biomasse1.jpg&imgrefurl=http://www.energielandschaft.de/energie/biomasse/grundlagen-biomasse/&h=331&w=505&tbnid=oC4qk7ux5hvWFM:&zoom=1&tbnh=90&tbnw=137&usq=__3rxCOehlZPltwOcbCE3VJ08II3M=&docid=hgyE9tHcuIxxqM
- [9] Agentur für Erneuerbare Energien,
<http://www.unendlich-viel-energie.de/erneuerbare-energie/bioenergie/kraftstoffe-aus-biomasse-marktentwicklung-2012>
- [10] Centrales Agrar-Rohstoffe Marketing- und Energie-Netzwerk e.V.,
<http://www.carmen-ev.de/biogene-festbrennstoffe/brennstoffe/holzpotential>
- [11] Fachagentur Nachwachsender Rohstoffe e.V.,
<https://mediathek.fnr.de/grafiken/daten-und-fakten/bioenergie/stromerzeugung-aus-biomasse.html>
- [12] Stepmap – Biomassekraftwerke in Deutschland,
<http://www.stepmap.de/karte/a-biomassekraftwerke-in-deutschland-136281>
- [13] VDE Verband der Elektrotechnik Elektronik Informatiktechnik e.V.,
<https://www.vde.com/de/fg/ETG/Arbeitsgebiete/V1/Aktuelles/Oeffentlich/Seiten/Biomassekraftwerke.aspx>
- [14] Agentur für erneuerbare Energie,
<http://www.unendlich-viel-energie.de/mediathek/grafiken/wie-funktioniert-ein-biomasse-heizkraftwerk>
- [15] VDE Verband der Elektrotechnik Elektronik Informatiktechnik e.V.,
<https://www.vde.com/de/fg/ETG/Arbeitsgebiete/V1/Aktuelles/Oeffentlich/Seiten/Biomassekraftwerke.aspx>
- [16] EnergieAgentur.NRW,
<http://www.energieagentur.nrw.de/biomasse/themen/vorteile-der-biomasse-9530.asp>
- [17] EnergieAgentur.NRW,
<http://www.energieagentur.nrw.de/biomasse/themen/nachteile-der-biomassenutzung-9532.asp>
- [18] Rocky Mountain Institute,
http://www.rmi.org/RFGGraph-US_biomass_consumption