

3. INGENIEURTAG 2016

DER FAKULTÄT MASCHINENBAU, ELEKTRO- UND ENERGIESYSTEME

GUS- UND OSTEUROPATAG

NESEFF-NETZWERKTREFFEN 2016

TAGUNGSBAND

Herausgeber: Prof. Dr.-Ing. habil. Sylvio Simon



Brandenburgische Technische Universität Cottbus-Senftenberg
IKMZ, Universitätsbibliothek
Platz der Deutschen Einheit 2
03044 Cottbus

ISBN 978-3-940471-28-4



IURS e.V.
Institut für Umwelttechnik und
Recycling Senftenberg e.V.

www.b-tu.de

Vorwort

Die GUS- und Osteuropatage der Fakultät Maschinenbau, Elektro- und Energiesysteme sind eingebunden in eine gesamte Veranstaltungswoche, deren zentrales Element der Triebwerkstag (10 Jahre UTC) ist. Mit dem Internationalen Tag in Senftenberg bestehend aus internationalem Brückenbauwettbewerb mit Liveschaltung zur SSOU nach Shanghai und den weiteren internationalen Vorträgen sowie dem Ingenieurtag mit Informationen über Forschungsprofessuren, Automatisierungstechnik und Fabrikplanung. Ein Treffen von Absolventen rundet diese Programmwoche ab.

Die Fakultät Maschinenbau, Elektro- und Energiesysteme entstand 2016 im Zuge der Neustrukturierung der Fakultäten der BTU CS nach ihrer Neugründung im Jahre 2013. Sie ging aus den Vorgängerfakultäten Maschinenbau, Elektrotechnik und Wirtschaftsingenieurwesen am Campus Cottbus und der Fakultät für Ingenieurwissenschaften am Campus Senftenberg hervor. Hier sind jetzt die Kompetenzen des Maschinenbau und der Elektro- und Energietechnik vereint.

Der Austausch mit Wissenschaftler aus anderen Ländern wird als Tradition an beiden Standorten gelebt. Neben dem Empfang von Wissenschaftlern und Studierenden gehört auch der Besuch in den jeweiligen Ländern dazu. Mit der Gründung des internationalen Netzwerkes neseff im Jahr 2015 in Baku entstand ein Netzwerk, das sich mit seinen Schwerpunkten Energieerzeugung und Energieeffizienz mit bedeutenden und zentralen Fragen der modernen Volkswirtschaften auf breitem Gebiet beschäftigt. Es hat seine Heimstatt im IURS e.V., einem An-Institut der BTU CS. Die Tatsache, dass weitere osteuropäische Universitäten dem Netzwerk beitreten werden, stärkt das Netzwerk und seine Akteure.

Zwischen den GUS- und Osteuropatagen der Fakultät 3, die erstmalig stattfinden und dem bereits zum 3. Mal stattfindenden Ingenieurtag in Senftenberg, er folgt der Tradition der Wissenschaftstage der Hochschule Lausitz, ist ein vielseitiges Vortrags- und Besuchsprogramm vorbereitet, das jedoch genügend Zeit für Gespräche und Diskussionen bietet. Ich wünsche uns Allen erfolgreichen Tage an der BTU CS.

Sylvio Simon,
wissenschaftlicher Leiter des Netzwerkes neseff

✉: neseff@iurs-ev.de

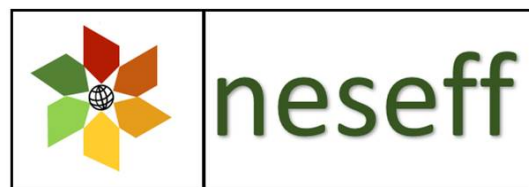

network for energy supply and energy efficiency

Inhaltsverzeichnis

1. NUMERICAL INVESTIGATIONS OF THE UNSTEADY FLOW IN MELTED ALLUMINIUM ALLOYS	1
2. EXERGY METHOD FOR EFFICIENCY ESTIMATION OF ENERGY INSTALLATIONS, PROCESSES AND SYSTEMS.....	5
3. OPTIMIZATION OF THE ENERGY EFFICIENT ACTIVE HOUSE I.A.....	8
4. REFRIGERATION GENERATION FOR THE CENTRALIZED REFRIGERATION SUPPLY SYSTEMS	13
5. TPP GAS SUPPLY SYSTEM BASED ON LNG USAGE AS A RESERVE FUEL.....	17
6. DEVELOPMENT AND IMPLEMENTATION OF ENERGY SAVING TECHNOLOGIES BY SCIENCE CENTER "WEAR RESISTANCE"	21
7. ПРОБЛЕМЫ ИСПОЛЬЗОВАНИЯ ДЕТАНДЕРНОЙ ТЕХНОЛОГИИ В РОССИЙСКОЙ ЭНЕРГЕТИКЕ.	25
8. OPTIMIZATION AND EFFICIENCY OF THE FINS	32
9. ОПТИМИЗАЦИЯ И ЭФФЕКТИВНОСТЬ РЕБЕР	37
10. ASH OF THERMAL POWER PLANTS: ENVIRONMENTAL AND ECONOMIC ASPECTS OF APPLICATION IN CONSTRUCTION	42
11. IMPROVING EFFICIENCY OF EXTERNAL WALLING DESIGN SOLUTIONS (ESPECIALLY FOR SEVERE CLIMATIC CONDITIONS)	48
12. DIE VORLÄUFIGE BEWERTUNG DES KOHLENSÄURENAUSBRUCHES VON DEN IN DER RUSSISCHEN FÖDERATION TYPISCH GEBAUTEN BAUPROJEKTEN.....	53
13. POWER SUPPLY IN THE KRASNOYARSK TERRITORY	60
14. INTRODUCTION TO THE ECO-CAMPUS ELEARNING PLATFORM	64
15. MECHANISMS OF ENHANCED INTERACTION OF REGIONAL RESOURCE AND PRODUCTION SYSTEMS	69
16. NEW IDEAS FOR FENESTRATION.....	72
17. THE INFLUENCE OF JUNCTION CONSTRUCTION OF BALCONY AND EXTERNAL WALL ON DISTRIBUTION OF HEAT EXCHANGE COEFFICIENT ON THE SURFACE OF MONOLITIC CONCRETE BALCONY SLABS.....	78
18. STROMERZEUGUNG DURCH ERDGAS- ENTSPANNUNG AM BEISPIEL EINES GRÖßEREN ERDGAS- VERBRAUCHERS	81

19. ВЫРАБОТКА ЭЛЕКТРОЭНЕРГИИ ТУРБОДЕТАНДЕРНОЙ УСТАНОВКОЙ В КРУПНОМ ПОТОКЕ ПРИРОДНОГО ГАЗА	86
20. IDENTIFICATION OF SEISMIC STABILITY OF HIGH-RISE BUILDINGS AND CONSTRUCTION OBJECTS BY CORRELATION MATRICES	87
21. UNIVERSITIES IN FACILITATING TRANSFER OF SCIENCE AND TECHNOLOGY IN ENERGY EFFICIENCY	98
22. MANAGING THE SUSTAINABLE DEVELOPMENT OF URBAN SYSTEM IN THE CONTEXT OF EUROPEAN INTEGRATION.....	104
23. EXPERIENCE OF USING VOLUNTARY SUSTAINABLE DEVELOPMENT STANDARDS IN ENERGY SPHERE	109
24. TEACHING ABOUT SUSTAINABILITY AT HIGHER EDUCATION INSTITUTIONS.....	114
25. UNTERSUCHUNGEN AN WÄRMETAUSCHERN FÜR FUSSBODENHEIZUNGEN.....	115
26. MATERIALS UND MINING 4.0 – DIGITALER TAGEBAU	120
27. ASSESSMENT METHOD OF WASTE PROCESSING SYSTEM.....	124
28. DIE DEUTSCHE "ENERGIEWENDE" UND DIE FOLGEN FÜR DIE BETRIEBS- UND INSTANDHALTUNGSSTRATEGIEN VON BRAUNKOHLEKRAFTWERKEN.....	125
29. THEORETICAL ANALYSIS OF THE INCREASE IN PRODUCTIVITY OF AUTOMATIC TRANSFER LINES.....	126
30. REMOTE-CONTROLLED TOOLS FOR DECONSTRUCTION TASKS ..	132
31. UNTERSUCHUNGEN ZUR FERTIGUNG STRUKTURIERTER KUNSTSTOFFTEILE MITTELS 3D DRUCK AUS BIOBASIERTEN MATERIALIEN.....	137
32. ENTWICKLUNG EINES METALL – KUNSTSTOFF – VERBUNDZAHNRADES	142
33. UNTERSUCHUNGEN ZUR TRAGFÄHIGKEIT STRUKTURIERTER BLECHE.....	147
34. ENERGIEEFFIZIENZ BEI ANTRIEBS- UND LOGISTIKLÖSUNGEN	152
35. AKTUELLE UNTERSUCHUNGEN AN TRAGROLLEN	157
36. UNTERSUCHUNGEN ZUR ENERGIEEFFIZIENZ BEI DER SPANENDEN BEARBEITUNG	162
37. ENERGY SAVING REGULATIONS IN GERMANY, HISTORY - STATUS – FUTURE.....	167

38. OPTIMIERUNG EINER VERSUCHSANLAGE ZUR ELEKTRISCHEN AUTARKIE.....	174
39. PRINCIPLES OF CREATION THE ENERGY-EFFICIENT RURAL AREA COMMUNITIES WITH BALANCED MATERIAL AND ENERGETIC FLOWS.....	175
40. ENTWICKLUNG UND OPTIMIERUNG VON ENERGIEEFFIZIENTEN LEICHTLAUFMOBILEN AN DER BTU COTTBUS – SENFTENBERG.....	179
41. THE MODEL OF ECONOMIC EVALUATION USE OF THE CAPACITY INTANGIBLE RESOURCES ON THE EXAMPLE OF RUSSIAN REGIONS.....	182

1. NUMERICAL INVESTIGATIONS OF THE UNSTEADY FLOW IN MELTED ALLUMINIUM ALLOYS

Karel Fraňa

¹Technical University of Liberec, Department of Energy Equipment, Liberec, Czech Republic

Abstract: Metallurgical processes require a huge amount of the energy needed for heating and transport of the melted materials. In order to control heat losses and temperature levels of the melted metal or alloys, a total heat balance in the furnace should be studied in order to improve operating conditions of furnace equipment. Significant temperature differences exist because of different heating fluxes. The numerical simulation of the heat and mass transfer can be applied in order to obtain the temperature and velocity fields of the melted metals. These results can be used to design operating conditions of the furnace as well.

Keywords: *numerical simulations, melting processes, temperature fields*

Introduction

The metal or generally fluid is melted and stirred in the main chamber of the furnace. During the metallurgical processes the temperature and chemical homogeneity are required [1]. The size of the main furnace chamber and the intensity of the fluid stirring can influence this heat process significantly. For instance, if the size of the chamber is too big or fluid stirring too weak, the flow is mixed only in some particular region of the chamber. The rest of the chamber region is not affected and the fluid has a tendency to be overheated or cooled. Furthermore, the quality of the doping of alloys is given by the effectiveness of the mixing process as well. To find appropriate conditions of furnace services, a numerical simulation of the melted fluid flows has been carried out. Results such as velocity or temperature distributions can predict a combination of operating conditions, under which the non-sufficient mixing process in the main chamber can be observed. The numerical study was carried out on the furnace designed by Stinchcombe Technology GmbH.

Problem formulation

The computational domain is defined by a box with one inflow and one outflow condition (see Figure 1). The liquid metal or generally fluid is melted and stirred in the main chamber of the furnace. The fluid flow behavior is governed by Navier-Stokes, continuity and energy equations. The mathematical model includes the turbulence model k-epsilon RNG [3]. Two phase flows were calculated by the Volume of Fluid (VOF) approach [2]. The parameter α denotes a fluid volume fraction and it takes a value as follows.

$$\alpha(x, t) = \begin{cases} 0 \\ 0 < \alpha < 1 \\ 1 \end{cases} \quad (1)$$

If the parameter α is 0, the cell is empty, in case of value 1, the cell is full of original fluid and values between 0 and 1 represent cells, where there is an interface between original fluid and another phase. The Volume Fraction equation is express in Eq. 2.

$$\frac{\partial \alpha}{\partial t} + \nabla \cdot (\alpha \vec{u}) = 0 \quad (2)$$

The computational mesh, depicts on Figure 1, was composed by tetrahedral type elements and defined by a number of 1.1 Mil. cells. The size of the main chamber was approx. 7x4x1.2 m. Boundary conditions were defined as adiabatic walls except inflow, outflow and atmospheric free surface conditions.

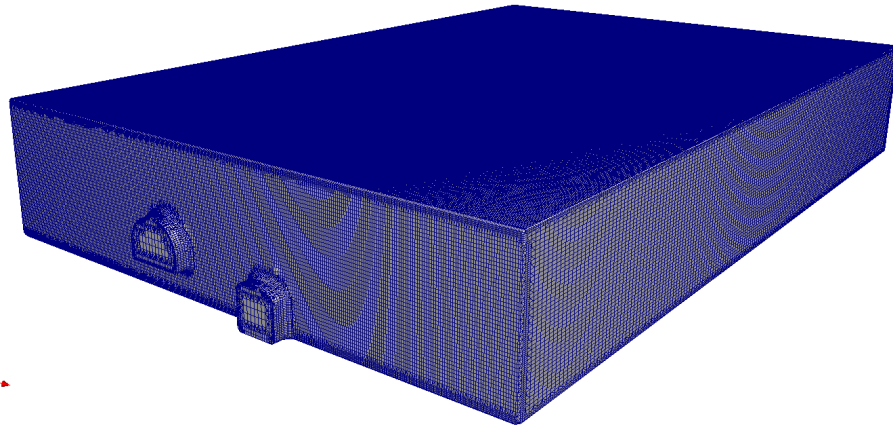

Fig.1.: The computational domain of the main furnace chamber with the meshing on surfaces

At the inflow, the input velocity was calculated based on the computational domain located in the front of the main chamber (not visible in the model depicted in Fig. 1). Calculations were performed using the OpenFOAM computational code. For the meshing, the SnappyHexMesh Tool was successfully adopted.

Results

Figure 2 illustrates isolines of the instantaneous velocity in the main furnace chamber. In this chamber, a metal is melted and mixed with other material components. Therefore, the intensified velocity field in the entire chamber is a basic condition for suitable mixing and homogenous temperature distribution. Figure 2 depicts that the fluid flow was too weak (or the main chamber was too long) to create fluid movement in the whole region of the main chamber.

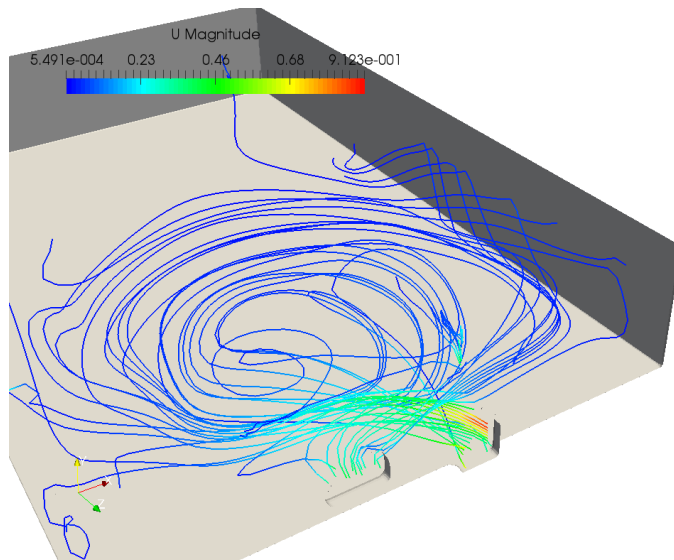

Fig. 2.: Isolines and velocity depictions in the main furnace chamber of the furnace designed by Stinchcombe Technology GmbH

In Figure 3, the instantaneous velocity field colored by the velocity intensity is depicted on the free surface. In the surface region close to the inlet and outlet, a strong flow exists. However, the velocity intensity doesn't exceed value of 1 m/s. For comparison, the fluid flow is stirred by the velocity of 3 m/s (not visible in the computational domain). The remotely region of the main chamber are not enough influence by the fluid flow entering and leaving via inflow and outflow boundaries. Figure 4 shows vertical flows depicted using vector fields. The red region represents the liquid metal and blue color is air above melted metal free surface.

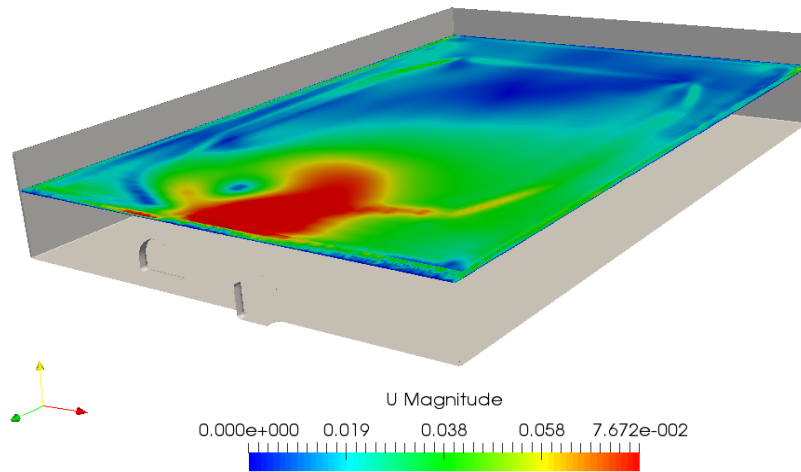

Fig.3: Instantaneous velocity field in a vertical slice

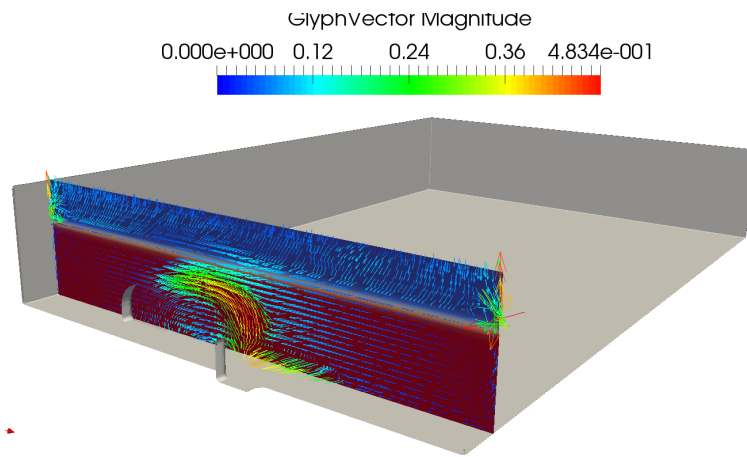

Fig. 4.: Instantaneous vector velocity on vertical slice in the main furnace chamber

Two different flows are created. The metal flow is generated by the force stirring and partially by a free convection. The air flow was driven only by a free convection. The numerical simulation of the flow inside of the main chamber revealed that the melted metal flow is sucked into the outflow condition immediately after entering into the main chamber.

Conclusion

Numerical simulations of the melted metal were carried out using OpenFOAM. The mathematical model with Volume of Fluids approach was applied. Results of CFD revealed that the flow inside of the main furnace chamber is too weak. Therefore no sufficient mixing of the melted metal alloys can be guaranteed in the entire domain. Moreover, the performed CFD flow study confirmed simultaneously the feasibility of CFD approach to solve numerically metallurgical problems.

Acknowledge

The work has been financially supported by the Moravian-Silesian Region in the frame of the industrial voucher.

References

- [1] *J. Campbell, "Complete casting Handbook: Metal Casting Processes, metallurgy, , Techniques of design", London, 2011, ISBN: 978-1-85617-809-9*
- [2] *C.W. Hirt, B.D.Nichols, "Volume of fluid (VOF) method for the dynamics of free boundaries", Journal of Computational Physics. 39 (1): 201–225, 1981*
C.G. Speziale, S. Thangam, "Analysis of an RNG based turbulence model for separated flows", Technical report NASA-CR-189600, 1992

Contacts:

Karel Fraňa
 Technical University of Liberec, Faculty of Mechanical Engineering,
 Department of Power Energy Equipment, Liberec, Czech Republic
 Tel: +420 724 746 020
 E-Mail: karel.frana@seznam.cz

2. EXERGY METHOD FOR EFFICIENCY ESTIMATION OF ENERGY INSTALLATIONS, PROCESSES AND SYSTEMS

Ekaterina V. Zhigulina¹, Nicolay V. Kalinin

Dept. of Industrial Heat Power Engineering Systems
National Research University "Moscow Power Engineering Institute"

Abstract: The article considers advantages of exergy method for effectiveness evaluation of blower and expansion appliances in comparison with other efficiency indicators. It is shown that in some cases the effect obtained from power installation can be determined only by means of the exergy efficiency. The unified approach for expansion power machines and expanders effectiveness evaluation based on the exergy method is presented. Examples are given of the definition of exergy efficiency as the most correct assessment for dual purpose and multi-purpose installations and systems.

Keywords: *adiabatic efficiency factor, exergy method, blower and expansion appliances, turbine, compressor.*

The determination of the effect generated by the blower and expansion machines and the effectiveness assessment of machines, plants and systems to which they belong – are the most difficult questions in engineering. This is explained by several factors. First, the efficiency of the processes occurring in the blower and expansion machines are often assessed in relative terms by comparing the ideal processes with valid ones. These indicators illustrate the perfection degree of processes and devices, but do not always characterize the effect created by this device. However, it is the correct definition of the process, or device, or installation effect that allows to estimate the produced result from technical and economic point of view.

In our opinion, the most correct way of the blower and expansion machines efficiency η determination is to use the ratio of the obtained effect E to the cost C , expressed in comparable units of energy:

$$\eta = \frac{E}{C} \quad (1)$$

It is logical that such efficiency η must satisfy the inequality $0 < \eta < 1$. However, in a number of widely known technical examples of formal use of this ratio is $\eta > 1$, that is just puzzled and criticism.

For example, the heat pump efficiency is usually measured by:

$$\varphi = \frac{Q_t}{N}, \quad (2)$$

called the transformation ratio. Here Q_t - the generated heat, N – the compressor consumption power. This ratio is always greater than one, and in the initial period of heat pumps application this caused the just baffled in the technique.

Even greater difficulties arise in the performance assessing of the combined plant for the heat and cold joint production. It is a widely spread situation when the combined plant total effect determination is obtained via summation of non-additive value of heat production - Q_t and cold production- Q_o . At the same time large values of this indicator do not characterize the quality of the produced heat and cold.

The solution of this problem was found when the exergy method was developed [1].

The exergy concept lies in the basis of this approach as a measure of entire converting in other forms of energy. This implies that energy is divided into two categories: one that can be completely converted in any other form of energy and the other that cannot.

The most common and simple example of expansion machinery performance assessment is to use the relative efficiency factor often called an adiabatic or isentropic efficiency factor η_s :

$$\eta_s = \frac{\Delta h}{\Delta h_s}, \quad (3)$$

where Δh and Δh_s are the enthalpy differences in the real and ideal isentropic processes of expansion, respectively. This indicator characterizes the perfection of the expansion process and takes into account the only single effect: in case of power machines – this effect is the received work, and in case of expanders- it is cooling down of the working fluid.

In fact, in any expansion process there is always a second effect, that can be used. In the case of power machines (steam or gas turbines) it is the temperature (enthalpy) at the outlet and it differs from environmental parameters.

The most vivid examples: counter-pressure steam turbines and combustion turbines with sufficiently high temperature of flue gas (e.g. 450÷500 ° C)

In General case exergy efficiency for any turbine can be evaluated via the following formula:

$$\eta_e = \frac{N_t + E_2}{E_{wm} + E_q}, \quad (4)$$

where N_t - available turbine capacity, that is given to a generator or a compressor or a pump, E_2 - exergy of working medium at the turbine output if the generated heat or cold is beneficial used, E_{wm} - working medium exergy at the turbine inlet, E_q - exergy of heat or cold supplied at the turbine inlet.

In the case of cogeneration exergy efficiency will be:

$$\eta_{e\ co} = \frac{N_t + E_{Qt}}{E_{wm} + E_q}, \quad (5)$$

where E_{Qt} is the exergy of consumed heat at temperature level of t .

There are many other examples in engineering when the effect obtained from the power installation can be determined only by means of the exergy efficiency.

The comparison of calculating formulas for some spread target ratios and for exergy efficiency when dealing with the most typical technical issues is described in table 1.

Table 1. Target ratios and exergy efficiency formulas for the most typical technical issues

Target ratios K	Exergy efficiency η_e
1. Boiler	
boiler efficiency $K = Q_r / Q_f$ Q_r – the received heat, Q_f - calorific value Usually $K \approx 0,80-0,90$	$\eta_e = (Q_r \times T_q) / (Q_f \times T_t) = K(T_q / T_t)$ T_q and T_t - coefficients of heat performance $\eta_e = 0,4-0,5$. depending on the allotted heat temperature level
2. Condensing power plant. Gas turbine plant without exhaust gas heat recovery	
$K = L / Q_f = (T - T_a) / T$ L - usable work T_a - ambient temperature	$\eta_e = L / Q_f \times T_t$
3. Combined heat and power plant with joint production electricity (L) and heat (QP), as well as gas turbine or gas installation using exhaust gas heat	
$K = (L + Q_u) / Q_f$ Q_u - usable heat Usually $K \approx 0,85-0,90$	$\eta_e = (L + E_{Qu}) / E_{Qf}$ E_{Qu} and E_{Qf} - exergy of usable heat and chemically bonded with fuel $\eta_e = 0,4-0,6$. depending on the allotted heat temperature level
4. Heat pump	
$K = \varphi = Q_u / L > 1$, ($\varphi = 2,5-5$) φ - transformation ratio	$\eta_e = Q_u \times T_q / L = \varphi \times T_q < 1$
5. Refrigeration unit	
$K = \varepsilon = Q_o / L = 1$ ε - coefficient of performance Q_o - cooling capacity	$\eta_e = Q_o \times T_o / L = \varepsilon \times T_o < 1$ T_o - performance quotient

References

[1] Brodyansky, V. M., *Exergy method of thermodynamic analysis.-M., Energy.1973-296 S.*

Contacts:

Ekaterina V. Zhigulina
 NRU "Moscow Power Engineering Institute", Russia
 Tel: 0079262865833
 E-Mail: ZhigulinaYV@mpei.ru

3. OPTIMIZATION OF THE ENERGY EFFICIENT ACTIVE HOUSE

*I.A. Sultanguzin¹, I.D. Kalyakin¹, A.V. Govorin¹,
B.A. Khristenko¹, Yu.V. Yavorovsky¹*

¹ National Research University «MPEI», Moscow, Russia

ABSTRACT

Now creation of the energy efficient house is an urgent problem which solution demands the system approach.

There are several modern concepts and technologies of energy efficient houses: passive house, active house, zero energy building, the eco-friendly "green" house, etc. Each of these concepts has the unique features, but they are united by the general orientation on creation of houses with the minimum energy consumption.

Power supply system of buildings on the basis of renewable energy resources becomes more and more attractive in comparison with usage of fossil fuels. In fact, it allows transferring the house to the category of active, reducing consumption of external energy resources practically to zero, and even to release an excess of the generated energy in the house to outside.

Development and operation of such systems represent big difficulties for many reasons. Therefore, it is necessary to have the tool which allows defining the best structure of the equipment and an optimal ratio of energy sources.

Formulation of energy efficient building optimization is the purpose of this work.

The minimum of construction and equipment costs, the consumed energy resources cost and damage from environmental impact of harmful emissions during life cycle of the building could be chosen as criterion of optimization.

Various energy resources; different construction materials; energy saving technologies; volume of energy storage could be used as the optimized parameters.

The solution of an optimizing task on mathematical model will allow determining the optimum parameters of energy supply system at which power independence of the considered object would be reached. It will allow preserving fossil fuels that is urgent at exhaustion of their reserves.

Keywords: *active house, passive house, renewable energy, fossil fuel, optimization, mathematical model, energy efficient building*

Introduction

In Russia construction of energy-efficient buildings with minimum energy consumption – is one of the basic tasks in solving energy saving problems. Here optimum solutions are to be estimated for north, moderate and south climate zones taking into account their specific characteristics.

In the same time energy system of this type of buildings should be analyzed in environmental aspect. Minimization emissions of harmful emissions and greenhouse gases (GHG), efficient utilization of life activity waste – one of the ways of increasing environmental safety. Taking into account the fact, that life-

cycle of building is much longer than operational lifetime of engineering systems, energy consumption and environmental impact should be estimated for all life-cycle of the building according to economic criteria with a glance to capital, operating and dismantling costs.

It is necessary to have an efficient tool to design, because taking in account characteristics of all climate zones is very important. In reconstructing of buildings it is important to predict the results of introduced changes.

Formulation of energy efficient building optimization is the purpose of this work. It will help to find optimum parameters of energy system [2], which includes sources, consumers of energy and connections between them, and reach minimum of energy consumption and environmental impact.

Formulation of optimization task

The problem of optimization of creation of energy efficient buildings by analogy with a problem of optimization of integrated steelworks and heat power installations [7] could be formulated as follows (1) – (6).

A problem concerning optimization of the energy supply system of building could be formulated as a mathematical problem in the following manner.

It is necessary to determine such parameters X and a type of the thermal scheme S that

$$C_{\Sigma} = F(X, Y(X), Z_K, S, A) \rightarrow \min \quad (1)$$

with constraints

- in the form of equations

$$E(X, Y(X)) = 0 \quad (2)$$

- in the form of inequalities

$$Y^* < Y(X) < Y^{**} \quad (3)$$

optimized parameters

of energy sources

$$X_{SOUR}^* < X_{SOUR} < X_{SOUR}^{**} \quad (4)$$

of energy saving technologies

$$X_{TECH}^* < X_{TECH} < X_{TECH}^{**} \quad (5)$$

of energy storages

$$X_{STOR}^* < X_{STOR} < X_{STOR}^{**} \quad (6)$$

for $A = A_0$,

where X – is a set of independent parameters, Y – is a set of the dependent parameters determined through system of the equations (2).

In order that energy efficiency optimization was spent by the form the thermal scheme of power technologies at building, it is necessary that the indicator S includes all possible variety of a type of the thermal scheme defined as a result of the analysis of functioning of energy supply system. Indicators of external factors at the solution of this task are considered to be set, i.e. $A = A_0$. Mainly the climatic conditions, technical and economic values necessary for determination of cost of separate elements of the power equipment, costs of fuel, depreciation, repair, etc. enter set of indicators A .

As criterion of optimization C_{Σ} the minimum of the total expenses including capital and operational expenditure for construction and the equipment, cost of

the consumed energy resources and damage from impact of harmful emissions on the environment during life cycle of the building could be chosen.

As the optimized parameters X could be used:

- various energy resources (natural gas, biomass, electric power, solar energy, wind power, warmth of soil, etc.);
- modern construction materials (gas-concrete blocks, mineral basalt wool, expanded polystyrene, polyurethane foam, etc.);
- energy saving technologies (heat pumps, recuperation of air and water waste heat, solar collector, solar photovoltaic (PV) panels, wind power installations);
- covering of basic and pick loads for energy supply of building (heating, hot water supply, ventilation, conditioning, power supply);
- volume of energy storages (the accumulators of hot water, rechargeable batteries, compressed air energy storage, etc.).

The solution of an optimizing task on mathematical model will allow determining the optimum parameters of energy supply system at which power independence of the considered object would be reached. It will allow preserving fossil fuels that is urgent at exhaustion of their reserves.

Realization of energy efficient buildings concepts

There are several modern concepts and technologies of energy efficient houses: passive house [3], active house [6], zero energy building [5], the eco-friendly "green" house, etc. Each of these concepts has the unique features, but they are united by the general orientation on creation of houses with the minimum energy consumption.

Power supply system of buildings on the basis of renewable energy resources becomes more and more attractive in comparison with usage of fossil fuels [1,5]. In fact, it allows to transfer the house to the category of active, reducing consumption of external energy resources practically to zero, and even to release an excess of the generated energy in the house to outside.

The results of residential house energy system modeling based on realization of passive and active house conceptions in Moscow Region climate zone allows us to make a conclusion, that it is possible to reach zero energy balance in inclement Russian climate conditions. Maximum decrease of energy consumption in buildings is reached by implementation of combination of these conceptions. In the same time energy independence increases and consumption of non-renewable energy sources decreases.

An important role in increasing of building energy independence plays energy storages. In particular, seasonal accumulation of heat energy overload, generated in solar collectors in summer period, is able to decrease energy consumption for space heating during autumn and winter periods essentially.

Nowadays a problem of energy efficient houses design is of current importance and requires a systemic approach. The highest standard for such kind of buildings – a passive house, which basic criteria are: specific space heating demand up to 15 kWh/(m²a), total primary energy rate up to 120 kWh/(m²a) [3]. There is still no passive house in Russia, but principles, components and design methods are already in use in some new buildings.

The mathematical model helps us to connect all components of building energy system: source, consumer and connections between them. A modeling of

energy efficient houses in Passive House Planning Package (PHPP) and designPH software (Fig. 1) allows not only estimating an energy balance of the building, but taking into account geometrical characteristics, eliminating thermal bridges, which is quite actual for the considered construction industry, where we have a large variety of architectural solutions. PHPP is a multipurpose tool, which can be used both in residential and public buildings [4].

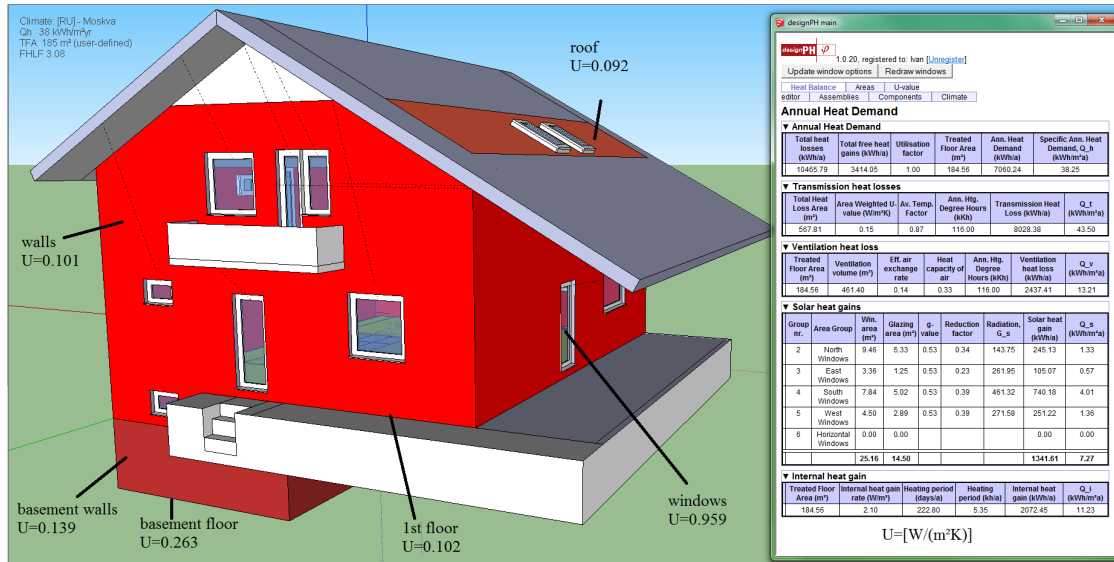

Fig. 1. Result of design of building in designPH and PHPP software

Requirements to thermal protection and energy consumption are getting more severe year by year. At the same time technological progress doesn't stand still. A new, more efficient materials and equipment are being developed and that is why energy parameters values (thermal conductivity, specific space heating demand, etc.) don't coincide with standard values, while traditional calculating methods for heating demand don't give us correct results of low energy consuming buildings analysis [4]. And it is necessary to make an optimization of selection of energy equipment (heat pumps, combined extract and input ventilation with heat recovery, solar collectors and PV panels, etc.) and heat - insulating materials.

According to passive house concept and PHPP software we could find decision which allows decreasing of energy consumption to 38 kWh/(m²a).

Next step is using of active house concept for decision of problem to achieve near zero energy building on the basis of renewable energy resources (solar energy, wind energy). Total primary energy consumption is 106 kWh/(m²a). It could be cover by renewable energy according to realization of thermal scheme (Fig.2). Just time this project in construction.

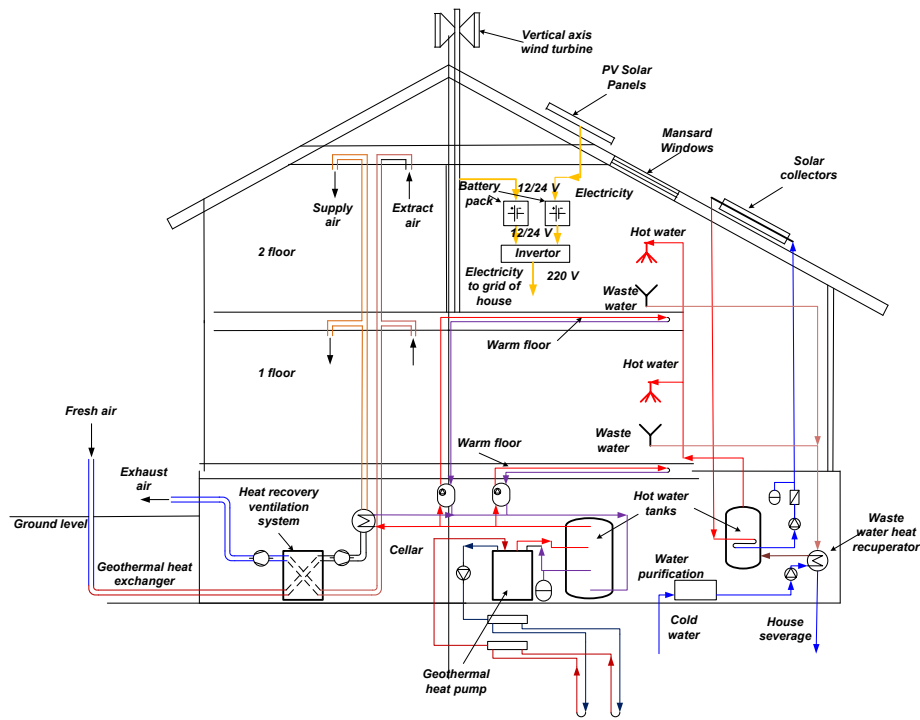

Fig. 2. Thermal scheme of energy supply system of building.

References

- [1] Carnevale E., Lombardi L., Zanchi L. Life Cycle Analysis of solar energy systems: Comparison of photovoltaic and water thermal heater at domestic scale // *Energy*, vol. 77, 2014, pp. 434 – 446.
- [2] Fabrizio E., Corrado V., Filippi M. A model to design and optimize multi-energy systems in buildings at the design concept stage // *Renewable Energy*, vol.35, 2010, pp. 644–655.
- [3] Feist W., Schnieder J. Energy efficiency – a key to sustainable housing // *European Physical Journal. Special Topics*, vol. 176, 2009, pp. 141 – 153.
- [4] Kalyakin I., Ashikhmina A., Sultanguzin I., et.al.. Application of Passive House Modeling Software to Design Residential and Public Buildings // *Proceedings of the International Academic Forum AMO–SPITSE–NESEFF*. Smolensk: Publishing “Universum”, 2016, p. 143.
- [5] Lu Y., Wang Sh., Zhao Y., Yan Ch. Renewable energy system optimization of low/zero energy buildings using single-objective and multi-objective optimization methods // *Energy and Buildings*, vol. 89, 2015, pp. 61 – 75.
- [6] Oliva A., Stryi-Hipp G., Kobelt S., et.al. Solar-Active-Houses – dynamic system simulations to analyze building concept with high fractions of solar thermal energy // *Energy Procedia*, vol. 70, 2015, pp. 652 – 660.
- Sultanguzin I.A., Isaev M.V., Kurzanov S.Yu. Optimizing the production of coke, coal chemicals, and steel on the basis of environmental and energy criteria // *Metallurgist*, vol. 54, 2011, pp. 600–607.

Contacts:

Sultanguzin I.

Affiliation: National Research University «MPEI», Moscow, Russia

Tel: +7-905-582-4333

E-Mail: SultanguzinIA@mpei.ru

4. REFRIGERATION GENERATION FOR THE CENTRALIZED REFRIGERATION SUPPLY SYSTEMS

Master, Borisova Polina¹

¹ National Research University "Moscow Power Engineering Institute"

Abstract: One of the possible ways to increase the efficiency of power generation is the creation different types of fuelless plants, which operation doesn't require gas burning. The scheme of fuelless plant based on the expander-generator unit (EGU) and steam compressive thermotransformer (SCTT) to generate electricity and refrigeration was proposed. The plant can be applied on technological decompression gas stations in the gas supply system to organize centralized power and refrigeration supply. The results of exergy analysis show, that efficiency of the proposed scheme of the centralized refrigeration supply is higher than efficiency of the scheme of the traditional decentralized refrigeration supply.

Key words: *centralized refrigeration supply, expander-generator unit, steam compressive thermotransformer, exergy analysis, power efficiency*

Main text:

The fuelless plants which operation don't require gas burning consist all plants using renewable source energy and some plants using particularity of the existing technologies. For example, the expander-generator units (EGU) are used in the gas supply system to generate electricity. It is important for Russia due to developed gas supply system.[1] The particularity of the gas supply technology permits using expander-generator units (EGU). Gas pressure in the gas mine usually is about from 4 MPa to 11 MPa.

Before the municipality or a major consumer, gas pressure is reduced at gas distribution stations (GDS) to 1.5 MPa, after which there is another pressure reduction step at the consumer of gas - gas control points (GCP) - where the gas pressure is reduced to the required value appropriate to consumption technology (0.5 - 0.2 MPa). The throttles are commonly used to reduce the pressure. However, the expander-generator units using gas pressure drop to generate electricity can be used instead of throttling devices. As is known, the gas temperature at the expander outlet without preheating the gas before it ranges from -80°C to -90°, which is unacceptable according to the operating conditions of the pipeline. To Preheat gas before the expander is usually used plants, in that organic fuel is burning (example, the transported gas).

The technical solution for preheating the gas before the expander is offered to allows operating EGU without fuel burning. For this target the thermotransformer is provided operating in the heat pump mode. The part of electricity generated at EGU (from 20% to 50% in dependence on the environmental condition) is used for operating the thermotransformer. The thermotransformer converts low grade heat, example the environment heat, into high temperature grade heat that is necessary for preheating the gas before the expander to required temperature. Further energy efficiency increase of the

plant is possible at the thermotransformer operating in the mixed mode, i.e. the simultaneous production of warm and cold. In such case generated heat at the thermotransformer is used to preheat the gas before the expander and generated refrigeration – for organizing centralized refrigeration supply of consumers. The schematic diagram of the offered plant is shown in Fig. 1 [2]

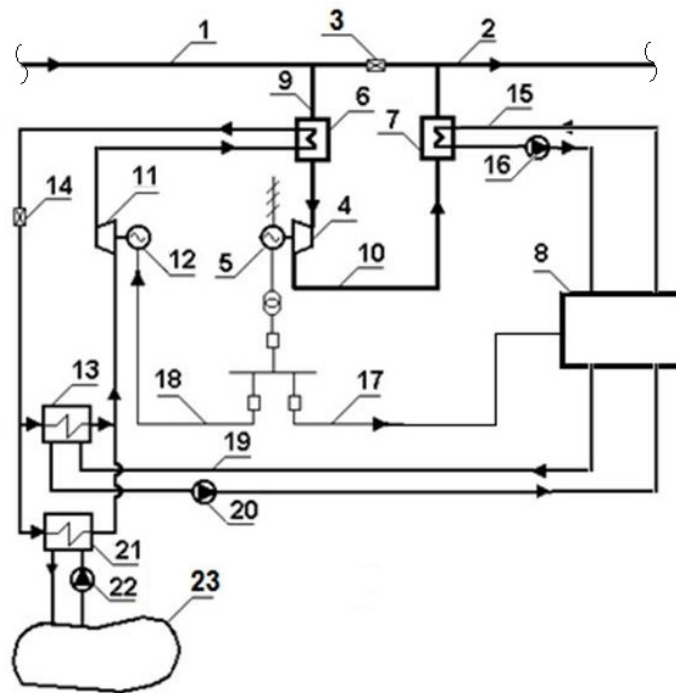

Fig. 1. Circuit diagram of the fuelless plant for the simultaneous production of electricity and cold

The plant operates as follows.

The incoming gas on GDS and GCP by the high pressure gas pipeline 1 is partially feed to the throttle 3 and by line 9 is partially feed to the heat exchanger 6, in which it is heated by working fluid of the steam compressive thermotransformer to the required temperature according to the operating conditions. After the gas comes to the expander 4, in which the part of the gas flow energy is converted into mechanical energy and then into electrical energy in a generator 5.

The gas pressure at the expander outlet is determined by pressure at low pressure gas pipeline 2. The gas temperature behind the expander can be adjusted at the expense of the preheating temperature change at the heat exchanger 6.

After the expander 4 the gas flow comes to the heat exchanger 7, in which the first refrigeration-carrier is feed to by the line 15 from consumer 8 for cooling. After the heat exchanger 7 the gas flow is feed to low pressure gas pipeline 2. The pump 16 is provided to feed the first refrigeration-carrier to consumer 8.

One part of the generated electricity at the generator 5 is transmitted by line 17 to consumer 8, other part is feed by line 18 to converter 12 for operating of the compressor 11 of SCTT.

The cooling agent of SCTT comes out from the evaporator 13 in gaseousness and is feed to compressor 11 of SCTT. After compression the cooling agent is feed to the heat exchanger 6, in which giving heat to the gas flow at the

expander 4 inlet is condensed. The cooling agent pressure of SCTT reduces to required value at the throttle 14, then it comes to the evaporator 13, in which the second refrigeration-carrier is also feed by the line 19 from consumer 8. The cooling agent transforms from liquid phase to gaseous phase at the evaporator 13 and is feed to the compressor 11 of SCTT. The cycle closed.

The compression pressure of the cooling agent at the compressor 11 is determined by the required level of the temperatures at the heat exchanger 6. The second refrigeration-carrier is feed to consumer 8 from the evaporator 13 by the pump 20.

As is known, for operating the steam compressive thermotransformer in mode of the simultaneous production of warm and cold the energy balance equation must be satisfied:

$$Q_{h.ex} = Q_{r.TT} + N_{c.TT} \quad (1)$$

where $Q_{h.ex}$ – heat is transmitted from the cooling agent to the gas flow at the heat exchanger 6, W; $Q_{r.TT}$ – refrigeration is transmitted from the cooling agent to the second refrigeration-carrier at the evaporator 13, W; $N_{c.TT}$ – electricity is supplied to the convertor 12 of the compressor 11, W.

In case, when equation (1) can't be satisfied because of shortage of the refrigeration flow $Q_{r.TT}$, the additional heat exchanger 21 is provided for plant operation. The cooling agent vapors at the heat exchanger 21 due low temperature grade heat flow fed to it with the pump 22 from the low temperature grade heat source 23.

The total refrigerating capacity of the considered plant is provided with refrigerating capacities of the heat exchanger behind the expander and the evaporator of SCTT.

Two refrigeration generators allow simultaneously providing consumer with refrigeration with different parameters, if it will be necessary, example, for foodstuffs freezing system and air conditioning system.

Other possible mode of the plant operation - refrigeration generation with same parameters. In his case, the total refrigerating capacity of the plant equals to the sum of the refrigerating capacities of the heat exchanger behind the expander and the evaporator of SCTT.

The offered plant can be considered such one of the ways of efficiency increase at existing objects of generation due plant operation without additional fuel burning.

The comparative analysis of the thermodynamic efficiency of two refrigeration supply methods was carried out. The first method is the centralized refrigeration supply using offered plant that is included in the steam power plant scheme. The second method is the decentralized refrigeration supply using steam compressive thermotransformers with an electrical drive that are established on the consumer area to generate refrigeration. The exergy efficiency was accepted as a criterion for comparison, since in the first method two types of energy (electricity and refrigeration) are produced at the object of generation.

The exergy efficiencies for two methods are below [3]:

$$\eta_{ex1} = \frac{E_{eSTU}}{E_{gin}} \quad (2)$$

$$\eta_{ex2} = \frac{E_{eSTU} + E_{eEGU} + E_{rout}}{E_{gin} + E_{rin}} \quad (3)$$

where $E_{g.in}$ – the gas flow exergy at the object of the generation inlet, W; E_{eSTU} – the electricity exergy is transmitted from the steam turbine unit to consumer, W; E_{eEGU} – the electricity exergy is transmitted from the expander-generator unit to consumer, W; $E_{r.out}$ – the the refrigeration flow exergy is transmitted from the object of the generation to consumer refrigeration supply, W; $E_{r.in}$ - the refrigeration flow exergy is transmitted from consumer to the object of the generation, W.

To solve the problem some limitations were adopted:

1. The enthalpy of gas flow at the inlet of the boiler of STU behind EGU equals the enthalpy of gas flow at the inlet of the plant as at the high pressure gas pipeline (i.e. generated electrical powers of STU in both methods are equal).
2. The temperatures of refrigeration-carriers fed to consumer and received from it to the heat exchanger behind the expander and to the evaporator of SCTT are equal respectively.

The analysis results show that thermodynamic efficiency of power supply using the offered plant is higher in the entire range of the considered parameters.

The theoretical researches results show that the total refrigerating capacity of the plant used in the gas supply system of 1000 kW power unit can be equal to 8 kW, which is sufficient to meet ventilation and air-conditioning systems demands for industrial and living area (about 70 m²) of a small energy generation object. In this case the total increase of the electric power that can be transferred to the consumer for technological needs is about 10 kW.

Thus, the plant using for the simultaneous production of electricity and refrigeration based on the expander-generator unit (EGU) and steam compressive thermotransformer in additional to the steam turbine unit allows refrigeration generation to organize centralized refrigeration supply of consumers and additional electricity generation without fuel burning. It allows increasing total electric power from STU and EGU supplied to the consumer about 1% while providing set load of the refrigeration supply system of consumer.

References

- [1] V.S. Agababov, "Using expander generator units in the gas industry" / STC OJSC "Gazprom", *Materials col., Energy saving and energy saving technologies in the energy sector of the gas industry.* –M., 2001. T.2. – p.50-53.
- [2] V.S. Agababov, N.O. Baidakova, A.V. Klimenko , RF Patent 158931, (*Otkrytiya. Izobreteniya, Moscow, 2015*)
- [3] V.M. Brodyansky, *Exergic method of thermodynamic analysis.* –M.: Energy. 1973. p. 296.

5. TPP gas supply system based on ING usage as a reserve fuel

Ekaterina V. Zhigulina¹, Valery G. Khromchenkov²

^{1,2}Dept. of Industrial Heat Power Engineering Systems

National Research University "Moscow Power Engineering Institute"

Abstract: The current research relates to the analysis of fuel economy efficiency increase possibility at thermal power plants (TPP) due to the transition from the use of black oil as a reserve fuel to liquefied natural gas (LNG) produced at the very station. Some original schemes of receiving and storing the liquefied natural gas as alternative reserve fuel generated by means of application of expansion turbines are proposed. The simulation results of the expansion process of two compositions natural gas with different contents of high-boiling fractions in the software package ASPEN PLUS, which confirmed the proposed circuit efficiency. It was shown that the choice of a particular circuit design depends primarily on the specific natural gas composition.

Keywords: *thermal power plant, natural gas, turboexpanders, methane, black oil*

Natural gas is the main fuel for the majority of district-heating plants and thermal power plants at the European part of Russia. Black oil is usually used there as the reserve fuel. It causes the expensive maintenance of black oil economy. Even at periods when black oil is not used at TPP it should be kept in a fluid condition and because of that there is necessity of its constant heating and circulation all year round. Besides oil-fired boilers have lower efficiency than gas-fired ones due to sediments of combustion products at heat exchange surface areas, higher temperature of the exhaust fumes and etc.

The research represents the technical solution that allows to generate, to store and to use the liquefied natural gas as the reserve fuel at heat supply sources and TPP instead of black oil.

At organic Ranking cycle TPP natural gas is consumed with low pressure (0.1 – 0.15 MPa). At the same time the pressure of natural gas arriving at TPP is about 0.5 - 1.2 MPa. Usage of turbo expanders for capturing the energy that is otherwise lost in the gas pressure letdown process, makes it possible to produce power and to cool the gas deeply.

Natural gas delivered to consumers, is a mixture of hydrocarbons, with a predominant share of methane (50 - 99%), as well as nitrogen, carbon dioxide and others. Cooling the gas by reducing its pressure via the turbo expander will condense some high-boiling fractions of hydrocarbons.

Fig.1 and 2 contains the obtained diagrams of two compositions of real gas (from Ishimbay-Magnitogorsk pipeline and Moscow region gas networks) with different contents of high-boiling components (temperature - entropy and enthalpy - entropy).

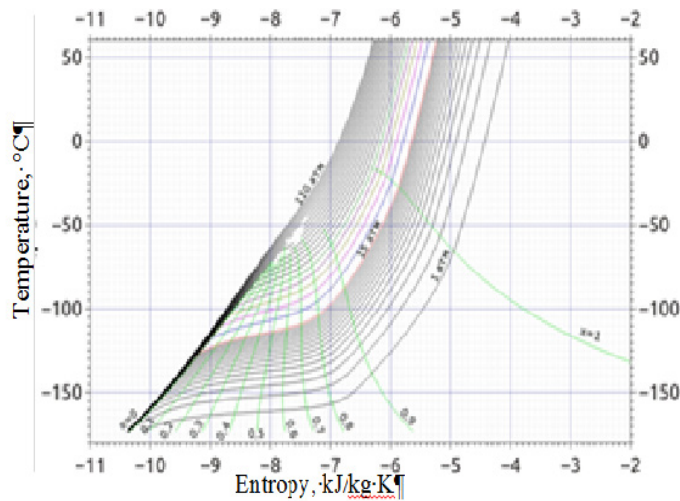

Fig.1 Thermodynamic diagrams of real natural gas (Ishimbay-Magnitogorsk pipeline)

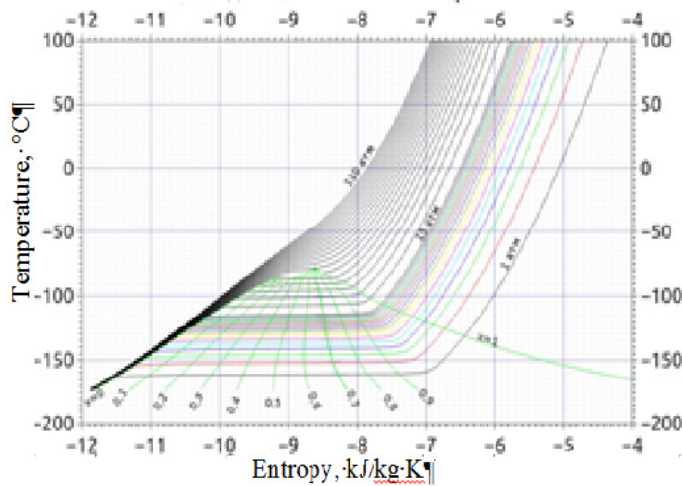

Fig.2 Thermodynamic diagrams of real natural gas (Moscow region gas networks)

It is shown that gas composition influences much to the isobars course in the two-phase field. In this area where the isobars have knees in two-phase field (under the saturation curve) methane begins to condense. So if working on gas with a lot of high-boiling fractions, it is possible to condense them even at atmospheric pressure at the temperature level of about -65°C, whereas in the case of low-boiling gas only at -130°C. This means that, additional cooling of the gas should be done in order to obtain the necessary amount of liquefied gas. It will complicate the technological scheme.

The calculation of the developed schemes (fig. 3a,b) was performed using the following data of Moscow TPP-23: the annual natural gas and black oil consumption, the composition and the technical characteristics of the main equipment.

The calculations were done using the comprehensive process modeling via Aspen Hysys. The calculations shows that it will take a little less than 9 months to accumulate the necessary amount of the reserve fuel.

This scheme cannot be used if work on natural gas with composition no. 2 consisting from 98% of methane. The problem is that the temperature level is not low enough for the methane condensation. So it was decided to use cold recovery, providing the preliminary cooling of the gas before the expander. The condensation outlet is almost 3 times bigger, then it was in the first scheme, so in this case the accumulation period of the reserve fuel is 3 months.

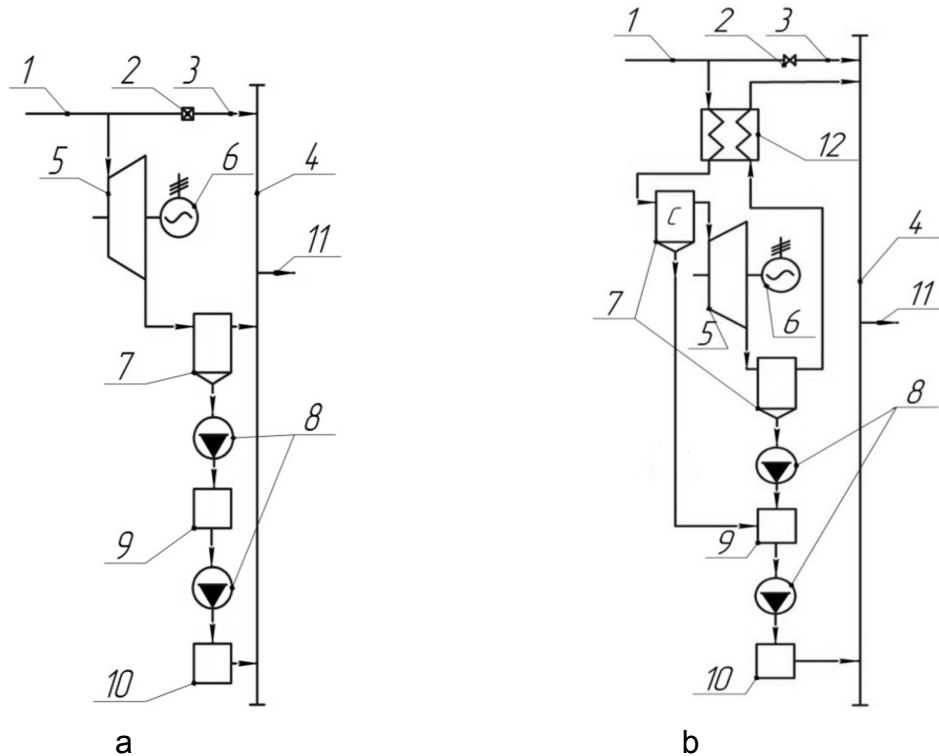

Fig 3. Schematic diagrams of scheme 1 (a) and scheme 2 (b)

1 — high pressure gas pipeline, 2 — throttle valve, 3 — bypass, 4 — low pressure pipeline, 5 — expansion machine, 6 — electric generator, 7 — separator, 8 — pump, 9 — storage tank, 10 — gasifier, 11 — to the consumer of natural gas, 12 — heat exchanger

The calculations for nine different compositions of natural gas were done for estimation of the feasibility of the first scheme usage.

CONCLUSIONS

- The possibility of liquefied natural gas usage as a reserve fuel at gas oil-fired thermal power plants (TPP) and boiler plants in Russia is considered.

- The estimation of the annual amounts of black oil and natural gas that are needed to ensure the reliable operation of several power plants in Russia has been done.
- Fundamental technical solutions for reserving at TPP the necessary amounts of liquefied gas are presented. The calculations have proved the effectiveness and the technical ability to use liquefied natural gas as a backup fuel at reconstructed and newly designed gas power station.
- The calculations showed that the first scheme can be applied only when work on natural gas with a high content of high-boiling fractions (more than 4-6 %).
- The increase of pressure of natural gas in the high-pressure pipeline from 9 up to 12 atm leads to the condensate mass fraction growth in the circuit 1 up to 1.6%, and in the circuit 2 to 0,43%.
- The increase of the total hydrocarbons mass fraction except methane involves a higher output of condensate (for example, when the total share of these components is increased for a 1%, the output of the condensate increases at 0.2%).

Contacts:

Ekaterina V. Zhigulina
NRU "Moscow Power Engineering Institute", Russia
Tel: 0079262865833
E-Mail: ZhigulinaYV@mpei.ru

6. DEVELOPMENT AND IMPLEMENTATION OF ENERGY SAVING TECHNOLOGIES BY SCIENCE CENTER "WEAR RESISTANCE"

A.V. Ryzhenkov¹, N.V. Ryzhenkova²

^{1,2}National Research University, Moscow Power Engineering Institute, Russia



ABSTRACT: The National Research University "Moscow Power Engineering Institute" scientific center "Improving wear resistance and reliability of the power equipment of thermal and electrical power stations" (short SC "Wear resistance") has been existing at since 1995.

The main activity of the Research Center is to create conditions for effective development and implementation of innovative technologies to improve reliability and life-

time of heat engineering and other equipment for the fuel and energy complex and its units such as turbines, compressors, stop-regulating valves, pumps, heat exchangers, piping tubes, etc.

In 2005, for the successful results in researching, developing and implementation of high technologies improving life-time and reliability of equipment into the Russian energy sector our colleagues were awarded with the Russian Federation Government Prize in Science and Technology field.

KEY WORDS: Scientific Center, MPEI, effective, thermal power plant, heat supply system, wear resistance, erosion, corrosion.

MAIN TEXT:

At present the staff of The Scientific Centre "Wear resistance" consists of more than 100 employees including professors (2), PhD (sci) (2) and candidates (14), scientific researcher (12), engineers (67), postgraduates (7) and masters.

The Scientific Center has a modern, unique scientific research and testing platform. The installed equipment permit to solve the following tasks:

- to study properties of structural material surfaces;
- to develop effective methods and techniques of hardening;
- to perform micro- and nano-composite saving coatings which as a whole essentially change properties traditional structural materials; with that both life-time of units is increased and their effectiveness is grown as well.

The Scientific Centre "Wear resistance" actively cooperates with young scientists (students, postgraduate from other universities), which are involved in the scientific and technical seminars, conferences, exhibitions and R & Ds.

SCIENTIFIC CENTER ACHIEVEMENTS

On the base of new developed techniques and instrumentation and equipment the following achievements were reached:

- increase of the erosion, abrasive, cavitation resistance of turbin main elements , boilers, pumps, stop-regulating valves etc., not less than 3 times.;

- almost complete stopping of corrosion processes in the paths of heating equipment and also heating and water supply systems;
- removing accumulated deposits and preventing the accumulation of new ones over the paths of TPP and NPP equipment and heat supply systems as well;
- reduction of hydraulic resistance of equipment and pipelines in the water transport systems and carbohydrates by 30 ÷ 40%;
- reduction of adhesion level of ice and frost on the metal surfaces, which improves heat transfer equipment effectiveness up to 40%, and also to decreases ice mass accumulation by 90%;
- removal of heat losses to the normative values, grow of energy efficiency and life-time (not less than 1.5 times) for heat transfers and TPP equipment and also heat supply systems on the bases of application of the developed thin-film thermal insulation coatings.

PROVEN TECHNOLOGIES

Under performing different tasks and R&Ds the following technologies were tested and proven:

- Technology of protecting the steam turbines blades from erosion, based on using micro- and nanoscale modifications of functional surfaces.
- Technology of improving energy efficiency and reliability of heat and water supply system in operating (SAW technology) (figure 1, 2).



Figure 1. Drops of water on the metal surface after SAW technology.



Figure 2. Mobile unit using to treat pipeline systems.

- The technology of reducing the heat power equipment losses on the basis of using the structured thin film the thermal insulation coatings.
- Technology of increasing the power unit efficiency, based on reforming film condensation into drop type one.
- Technology of increasing stop valves operation ability, based on the use of wear-resistant coatings.
- Technology of improving the tribological characteristics of the the heat power equipment functional surfaces on the basis of "slippery" coatings (figure 3).



Figure 3. Industrial issue turbine blades with "slippery" coating.

- Technology of the effective protection of the heat power equipment from atmospheric corrosion during repairs and long downtimes.
- Combat technology to the phenomena of icing on the elements of electric and thermal power equipment.

- Technology of energy consumption reducing for operating pumps in pipeline systems.
- Technology of electric power producing on the basis of the pipelines system overpressure recovery.
- Technology of preventing the icing phenomena of electric and thermal power equipment elements.

CONCLUSION

In conclusion it necessary to underline that SC is a modern institution of innovative technologies platform for research and development in the Russian energy sector. Besides this SC gives opportunities to students to reach progress and success in their scientific carrier.

Contacts:

Main Author Nadezhda Ryzhenkova
Affiliation: National Research University, Moscow Power Engineering
Institute
Tel: +74953627578 add 229
E-Mail: nadya.ryzhenkova@gmail.com

7. ПРОБЛЕМЫ ИСПОЛЬЗОВАНИЯ ДЕТАНДЕРНОЙ ТЕХНОЛОГИИ В РОССИЙСКОЙ ЭНЕРГЕТИКЕ

1Куличихин В.В., 2Тюняев М.В.

^{1,2} Национальный исследовательский Университет «МЭИ»

АННОТАЦИЯ. Рассматриваются проблемы внедрения детандерной технологии на энергетических объектах России для выработки электрической энергии и/или холода с использованием избыточного давления природного газа.

КЛЮЧЕВЫЕ СЛОВА: природный газ, избыточное давление, детандерная технология, особенности эксплуатации.

В западных странах Европы получили достаточное распространение детандер-генераторные агрегаты (ДГА), использующие избыточное давление природного газа в магистральных трубопроводах для производства электроэнергии и/или холода.

В России количество этих реально эксплуатирующихся агрегатов можно пересчитать по пальцам одной руки, при этом отмечаются случаи вывода их из эксплуатации.

По мнению авторов данной статьи, слабое использование детандерной технологии в России объясняется, во-первых, неочевидностью ее эффективности и преимуществ, а во-вторых, необходимостью обеспечения определенных и существенных условий, при которых она может быть применена на объектах внедрения.

Авторы многочисленных газотурбинных двигателей. Однако их характеристики обычно не соответствуют условиям работы ДГА, что снижает их эффективность.

Из-за малого спроса на установки подобного типа стоимость и сроки изготовления ДГА, несмотря на использование имеющихся у заводов разработок, значительны, что снижает привлекательность проектов с ДГА. Также отсутствует типовая методика технико-экономического обоснования целесообразности применения ДГА, утвержденная соответствующими органами, с последующим учетом особенностей каждого конкретного объекта

И, наконец, самое главное, по мнению авторов статьи, в России вообще объективно отсутствуют области целесообразного применения ДГА.

Так, например, применение ДГА на крупных энергетических объектах, например, на теплоэлектроцентралях (ТЭЦ), где имеются достаточно большой расход природного газа и источники тепловой энергии, не представляет для ТЭЦ никакого интереса из-за малой электрической мощности ДГА. Она обычно составляет менее 1% установленной мощности ТЭЦ. Кроме того, из-за низкого коэффициента использования установленной мощности (КИУМ), который в настоящее время составляет около 40–50%, на ТЭЦ имеется большой резерв электрической мощности. В связи с этим на них отсутствует необходимость и целесообразность внедрения маломощных ДГА.

Режимы подачи природного газа на ТЭЦ характеризуются значительной неравномерностью как по расходу природного газа, так и по его давлению на газораспределительном пункте (ГРП) (рис. 1). В частности, это объясняется закачкой природного газа в подземные хранилища перед началом переходного и отопительного сезонов. В результате графики электрической нагрузки ДГА становятся резко переменными с пониженным КПД на частичных нагрузках. А это приводит к существенному уменьшению годовой выработки электроэнергии на ДГА, что в свою очередь снижает эффективность и увеличивает срок окупаемости затрат на внедрение ДГА.

публикаций по данной тематике почему-то оставляют вне поля своего внимания обстоятельства, свидетельствующие о том, что:

- детандерная технология не является стопроцентной энергосберегающей, поскольку для производства в ДГА электроэнергии требуется тепловая энергия из постороннего источника необходимого потенциала для подогрева природного газа перед и/или за ДГА,

- детандерная технология не является стопроцентной экологически «чистой», поскольку природный газ, прошедший через ДГА, все равно сжигается у потребителя на последней стадии его использования,

- детандерная технология не является тригенерационной, поскольку она может использоваться для выработки электроэнергии и/или холода, но не может одновременно осуществлять еще и выработку тепловой энергии. Напротив, как указано выше, для подогрева природного газа перед и/или за ДГА в случае выработки электроэнергии необходима подача тепловой энергии из постороннего источника необходимого потенциала,

- детандерная технология не является технологией, термодинамическая эффективность которой научно доказана на основании эксергетического метода термодинамического анализа [1]. Нет ни одной научной работы по данному вопросу.

Тем не менее, в течение последних двадцати лет рекомендации по ее использованию регулярно появляются в России в многочисленных статьях в солидных научных изданиях и защищенных диссертациях.

Оставляя вопрос о термодинамической эффективности ДГА на последующие публикации, рассмотрим практическую сторону данной проблемы. Следует отметить, что заводы-изготовители в России с целью снижения затрат на создание ДГА стремятся использовать имеющиеся у них разработки из других областей техники, например, газовые турбины от авиационных и/или судовых



Рис. 1. Потребление природного газа на ТЭЦ-23 филиала ОАО «Мосэнерго»

На объектах малой энергетики ДГА также вряд ли найдут применение, так как на этих объектах одновременно должны находиться в распоряжении как источники тепловой энергии необходимого потенциала для подогрева газа перед и/или за ДГА, так и достаточно большой расход газа с целью получения хоть сколько-нибудь значимой электрической мощности.

Следует отметить, что обычно для оценки перспектив ДГА для различных целей авторами опубликованных работ используется как бы «эталонный» ДГА с расходом природного газа 1000 куб. м/ч и КПД 80% при различных комбинациях давлений и температур природного газа перед и/или за ДГА. Однако если по известным методикам теории турбомашин рассчитать проточную часть осевого ДГА в широком диапазоне изменений давлений и температур природного газа для указанного расхода 1000 куб. м/ч, то окажется, что длина сопловой лопатки его первой ступени на 3000 об/мин не будет превышать 1,2 мм. Очевидно, что такую проточную часть ДГА невозможно изготовить даже на самых современных металлообрабатывающих станках. В данном случае о каком-либо КПД такой ступени вообще не приходится говорить [2].

Следовательно, для увеличения длины лопатки до приемлемых величин, например, до 120 мм, необходимо увеличить расход газа в 100 раз, т.е. до 100.000 куб. м/ч. Такое увеличение расхода природного газа потребует и соответствующего увеличения в 100 раз тепловой энергии для подогрева газа из постороннего источника.

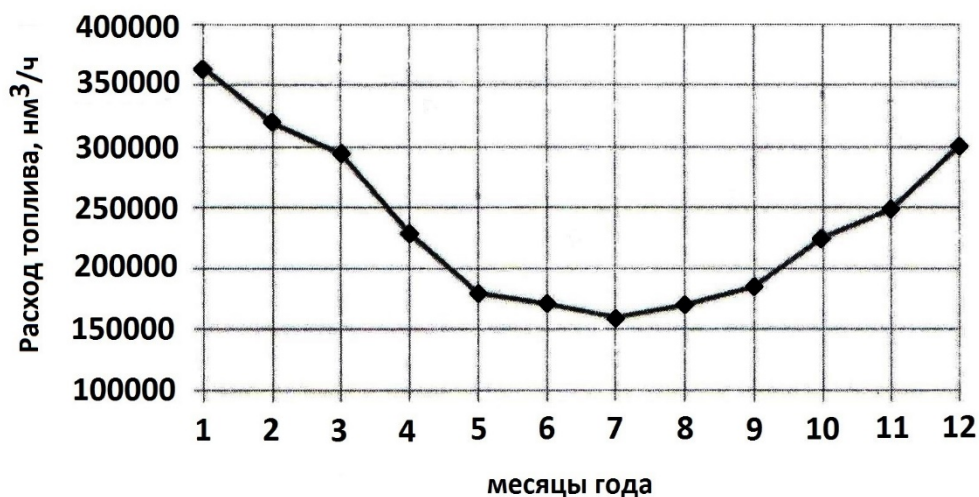
Но такие расходы природного газа и тепловая энергия необходимого потенциала имеются только на крупных энергетических объектах – ТЭЦ (см. текст выше).

Из этого следует очевидный вывод о том, что внедрение ДГА на объектах малой энергетики с незначительными расходами природного газа оказывается невозможным в силу невозможности создания соответствующего оборудования.

Определенный интерес по проблеме использования ДГА на крупных энергетических объектах представляют результаты исследований характеристик и длительный опыт эксплуатации в системе Мосэнерго четырех ДГА мощностью 5 МВт каждый, установленных на ТЭЦ-21 (2 ДГА) и ТЭЦ-23 (2 ДГА).

Общая электрическая мощность системы Мосэнерго составляет около 15000 МВт, в том числе на ТЭЦ-21 – 1645 МВт, на ТЭЦ 23 – 1420 МВт.

Таким образом, доля ДГА в системе Мосэнерго до их вывода из эксплуатации составляла 0,13%, на ТЭЦ-21- 0,607 %, на ТЭЦ-23 – 0,704%.

На рис. 2 с использованием сюжета известной басни «Слон и моська» русского баснописца И.А.Крылова наглядно показано это соотношение.



Рис. 2. Соотношение мощности Мосэнерго, ТЭЦ-21, ТЭЦ-23 и ДГА (доля ДГА в Мосэнерго — 0,133%, доля ДГА на ТЭЦ-21 — 0,607%, доля ДГА на ТЭЦ-23 — 0,704%)

Из него следует, что на вопрос, нужна ли такая дополнительная мощность ДГА в системе Мосэнерго, ответ очевиден. Не нужна.

Тем не менее, прежним руководством Мосэнерго в порядке эксперимента было принято решение о монтаже в 1995 г. двух ДГА на ТЭЦ-21 и примерно через десять лет - двух ДГА на ТЭЦ-23 аналогичной конструкции.

Первый из авторов статьи был включен руководством Мосэнерго в состав комиссии по сдаче и приемки ДГА в эксплуатацию и поэтому знаком со всеми этапами и особенностями выполненных работ.

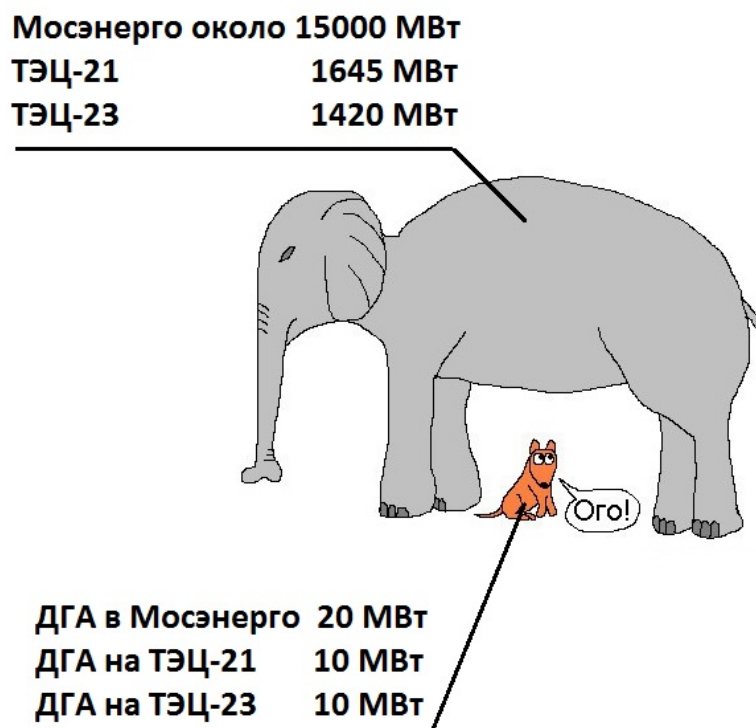
На рис. 3 показана принципиальная тепловая схема энергокомплекса с двумя ДГА.



Рис. 3. Принципиальная тепловая схема энергокомплекса с двумя детандер-генераторными агрегатами.

По договору с Мосэнерго под руководством и непосредственном участии первого автора данной статьи группой сотрудников НИУ «МЭИ» в 1995 г. впервые были проведены серии исследований характеристик ДГА. Их результаты были доложены этим автором еще в 1995 г. на XXVII энергетическом коллоквиуме Технического университета г. Дрездена (Германия) [3] и опубликованы в [4].

На рис. 4 показаны расчетные и экспериментальные данные эффективности ДГА.

Достаточно низкий по сравнению с западными образцами КПД проточной части на номинальной нагрузке, быстрое его снижение на частичных нагрузках объяснялись тем, что в качестве детандера была применена высокооборотная двухступенчатая газовая турбина с редуктором от судового газотурбинного двигателя. Какие-либо доработки для ее использования в качестве ДГА заводом не производились.

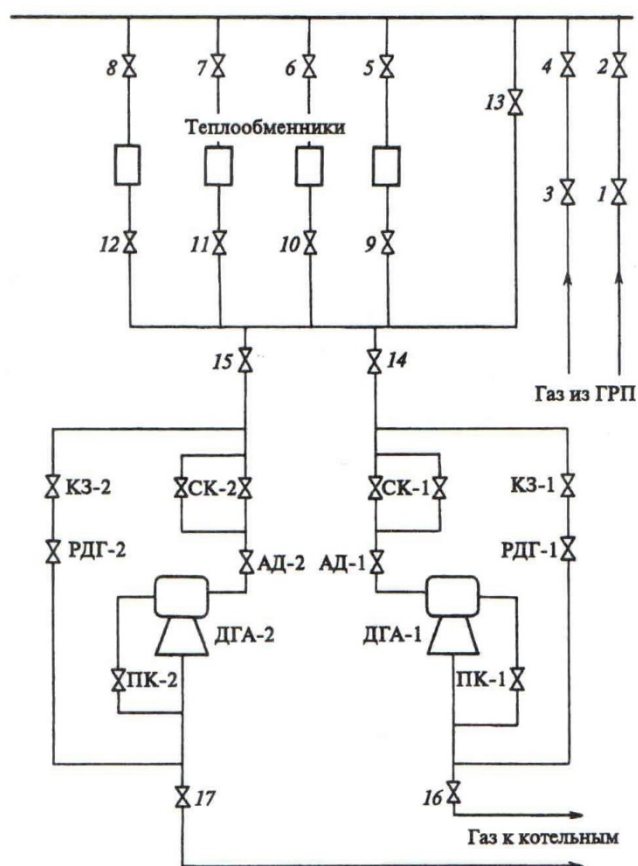
Проведенные расчетные исследования показали, что путем оптимизации проточной части его КПД может быть повышен примерно на 6% до уровня западных образцов в 83–85% [4].



Рис. 4. Расчетные и экспериментальные данные эффективности ДГА:

- · — · — расчетное значение КПД
- экспериментальные значения КПД (× — первая серия испытаний; ○ — первая серия испытаний с измерениями по светолучевому осциллографу; Δ — вторая серия испытаний,
- — расчет КПД по измеренной электрической мощности и расчетному значению расхода газа

На рис. 5 показано наличие больших гидравлических потерь в теплообменниках (по ходу газа), в стопорном и регулирующем клапанах (18%). В самих клапанах потери при их полном открытии составляли примерно 9%, что существенно выше, чем в клапанах современных паровых турбин.

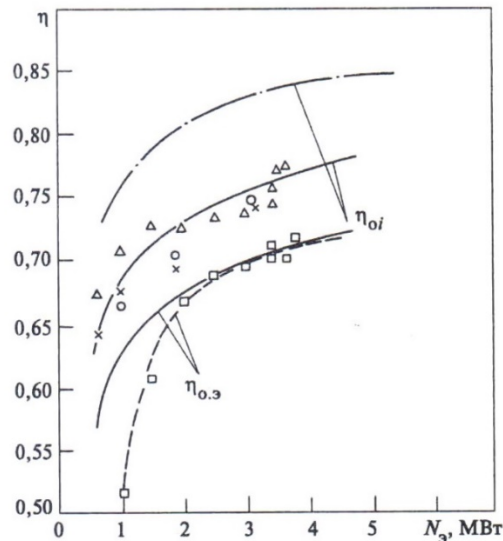

Рис. 5. Потери давления в стопорном и регулирующем клапанах ДГА: p_{0r} — давление газа перед теплообменниками, p_1 — давление газа на входе в ДГА

Повышенные потери давления природного газа в теплообменниках перед ДГА, в его стопорном и регулирующем клапанах, сравнительно низкий уровень КПД проточной части ДГА на номинальной нагрузке, резкое его снижение на частичных нагрузках, значительное снижение годовой выработки электроэнергии по сравнению с ожидаемой в связи с

уменьшением расхода и давления природного газа в летние месяцы в течение ряда лет определили недостаточную эффективность ДГА в целом.

В этих условиях у собственника ДГА хронически не хватало средств на оплату услуг ТЭЦ, в том числе за аренду земельного участка, предоставление инфраструктуры ТЭЦ (трансформаторная подстанция, распределительное устройство и т.д.), подачу тепловой энергии для подогрева природного газа перед ДГА, предоставление вахтенного и ремонтного персонала.

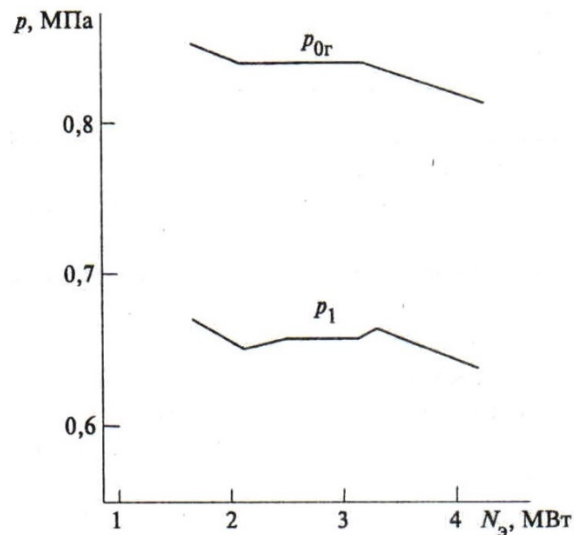
Собственник ДГА обращался к руководству Мосэнерго с просьбой о повышении тарифа на вырабатываемую ДГА электроэнергию, об исключении периодов снижения расхода и давления природного газа в летние месяцы, в чем ему было отказано в связи с отсутствием законных оснований и отсутствием возможности Мосэнерго влиять на газоснабжающее предприятие.

С учетом всех этих обстоятельств руководством Мосэнерго примерно шесть лет назад было принято решение о выводе этих ДГА из эксплуатации.

На основании длительного и негативного опыта эксплуатации ДГА на ТЭЦ Мосэнерго, по мнению авторов статьи, сегодня отсутствуют объективные предпосылки для внедрения ДГА на ТЭЦ России, по крайней мере, до принятия государственной программы компенсаций и льгот, например, путем введения повышенных тарифов на произведенную электроэнергию или путем снижения налогов [5].

Однако в настоящее время в связи с неудовлетворительным состоянием экономики России, введением санкций со стороны Европейского Союза, падением курса рубля и другими негативными факторами принятие такой программы проблематично.

Литература

1. Kalinin N., Zhigulina Y., Kulichikhin V. Effectiveness Evaluation of Blower and Expansion Appliances as Part of Equipment and System//Proceedings of the International Academie Forum AMO-SPITSE-NESEFF, 20-25 June 2016 Moscow-Smolensk, s. 111.
2. Экономичность, габаритные показатели и конструктивные схемы турбодетандеров // В.В. Куличихин, Н.А. Зройчиков, А.В. Асташкин, Л.Я. Лазарев, В.В. Чижов // Энергосбережение и водоподготовка, 2003 г., № 2.
3. Kulichikhin V.V. Die Nutzung des Energiepotentials Erdgases zur Erzeugung von Elektroenergie // Тезисы докладов на XXV11 энергетическом коллоквиуме Технического университета г. Дрездена (Германия), 1995 г.
4. Методика и результаты исследования характеристик детандер-генераторного агрегата // В.В. Куличихин, Л.Я. Лазарев, В.В. Чижов, В.Ф. Савенков // Вестник МЭИ, 2001 г., № 4.
5. Куличихин В.В., Лазарева О.О. Использование избыточного давления природного газа на промышленных предприятиях // Надежность и безопасность энергетики, 2010 г., № 2.

17 октября 2016 года
Куличихин В.В.
Тюняев М.В.

8.OPTIMIZATION AND EFFICIENCY OF THE FINS

1V.S. Glazov, 2G.N. Afonina, 3E.A. Gabdrakhmanov

^{1,2,3}National research University MPEI, Moscow, Russia

Annotation: In der vorliegenden Arbeit finden Sie die Aufgabenstellung und die Aufgabenlösung der Optimierung der Kühlrippe. Der Bereich seiner maximalen Wärmeabgabe und das entsprechenden Gebiet der thermischen Effizienz sind definiert.

Das grafische Material wird präsentiert, welches bei der Entwicklung des Plattenwärmeaustauschers verwendet werden kann.

Schlüsselworte: *Kühlrippe, Optimierung, Effizienz, Wärmetauscher.*

1. Einleitung

Die Aktualität dieser Arbeit für die gewerbliche Wärmeenergieerzeugung zeigt sich in der Notwendigkeit einer Verringerung der Abmessungen der modernen Wärmetauscher- Systeme bei gleichzeitiger Steigerung ihrer Energieeffizienz.

Die Erhöhung der wärmeübertragenden Fähigkeit des Wärmetauschers kann mit unterschiedlichen Lösungsansätzen erreicht werden, unter Anwendung des Newton-Richmans Gesetzes:

$$Q = \alpha \cdot \Delta t \cdot F, \quad (1)$$

mit α – Wärmedurchgangskoeffizient, Δt – Temperaturdifferenz zwischen der Wand und dem Wärmeträger, F – Wärmeaustauschfläche.

Man kann den Wärmedurchgangskoeffizienten (α) durch die Intensivierung des Wärmeaustausches erhöhen, durch die Wahl des entsprechenden Reliefs für die Wärmeaustauschfläche [1-2]. Die Erhöhung der Temperaturdifferenz (Δt) zwischen der Wand und dem Wärmeträger ist nicht immer möglich aufgrund der technologischen Nebenbedingungen. Die Erhöhung der Oberfläche (F) ist eine der effektivsten Möglichkeiten der Intensivierung des Wärmeaustausches, die durch das Berippen oder die Bestiftung der Fläche erfolgt. Es gibt eine Vielzahl von Kühlrippen, deren Form und Größe die Effizienz und die Höhe des zu übertragenden Wärmestroms beeinflussen. Neben den dreieckigen Kühlrippen hat eine konkave parabolische Kühlrippe, bei gleicher Masse, eine höhere Effizienz, als andere Kühlrippen oder sie besitzt bei gleicher Effizienz ein geringeres Gewicht [3]. Andere Publikationen, die sich mit der Effizienz verschiedener Kühlrippenformen beschäftigen (auch mit der gleichen Kühlrippenform), stellen keine Untersuchungen zum Einfluss der Höhe der Kühlrippe (bei gleichbleibenden Metallaufwand) auf die Wärmeeffizienz an.

Es wird angenommen, dass der passende Parameter für die Berechnung des Wärmestroms von thermisch dünnen Kühlrippen *der Wirkungsgrad der Kühlrippe* ist, welcher durch das Verhältnis - der Wärmeströme von realen und idealen Kühlrippen definiert ist.

$$\eta = Q_{real}/Q_{ideal} \quad (2)$$

Es wird vermutet, dass diese Kühlrippen die gleiche Form und Temperatur an der Basis besitzen. Sie unterscheiden sich voneinander lediglich durch die Wärmeleitfähigkeit, die bei der idealen Kühlrippe unendlich groß ist.

Für die direkte Rechteckkühlrippe mit einer wärmeisolierten Kühlrippenspitze hat der Wirkungsgrad die folgende Form:

$$\eta = \tanh(\sqrt{Bi_{rip}}) / \sqrt{Bi_{rip}} \quad (3)$$

mit Bi_{rip} - Biot-Zahl der Kühlrippe, der folgendermaßen definiert ist:

$$Bi_{rip} = \alpha \cdot \Pi \cdot L / (\lambda \cdot F) \quad (4)$$

wobei α – Wärmedurchgangskoeffizient, Π – Umfangslänge der Kühlrippe, L – Länge der Kühlrippe, λ – Wärmeleitfähigkeit des Kühlrippenmaterials, F – Querschnittsfläche der Kühlrippe.

Aus der Gleichung (3) folgt, dass die Wirksamkeit einer solchen Kühlrippe schnell mit einer steigenden Biot-Zahl sinkt. Deshalb kann die Situation entstehen, dass bei einem kleinen Wirkungsgrad der Kühlrippe die Oberfläche ohne Kühlrippen die Wärme besser abgibt, als mit Kühlrippen [4].

Die Qualitätsbewertung der Wärmeabgabe der Rechteckkühlrippe zeigt, dass sich einerseits die Wärmeabgabe erhöhen soll mit einer Steigerung der Höhe (der Wärmeaustauschfläche) bei konstantem Metallaufwand und andererseits wegen dem intensiven Wärmeaustausch zwischen dem oberen Teil der Kühlrippe und der äußeren Umgebung auch sinken kann. In diesem Fall wird bei großer Kühlrippenhöhe, ein Teil nahe an der Spitze, eine Temperatur nahe oder gleich der Umgebungstemperatur besitzen. Dies führt zu einer Null-Wärmeabnahme auf diesem Teil der Kühlrippe und damit zu einer ineffizienten Nutzung. Daraus folgt die Annahme der Existenz von Kühlrippenparametern, bei denen die Wärmeübertragung maximal sein wird und somit die Effizienz der Kühlrippe optimal sein wird, die durch die Formel (3) definiert ist.

Ziel und Aufgaben der Arbeit. Das Ziel dieser Arbeit besteht in der Bestimmung des Zusammenhangs zwischen der maximalen Wärmeabgabe und dem Wirkungsgrad der Rechteckkühlrippe. Um dieses Ziel zu erreichen ist es notwendig:

- die Aufgabe zur Optimierung der Rechteckkühlrippe zu lösen;
- einen Ausdruck zu bestimmen, der die maximale Wärmeabgabe der Kühlrippe der vorliegenden Form mit ihrer Effizienz verbindet.

2. Optimierung der Rechteckkühlrippe

Die Aufgabenstellung und die Aufgabenlösung. Es ist notwendig, die Parameter einer Rechteckkühlrippe, die für eine maximale Wärmeabgabe bei einem bestimmten Metallaufwand sorgen-, und die Nebenbedingungen für die minimal zulässige Dicke der Kühlrippe zu definieren.

Das *mathematische Modell* des Optimierungsproblems hat die folgende Form:

- Zielfunktion: $Q_{pe6} \rightarrow \max$ (5)
- Nebenbedingungen:

(6) Wärmeausbreitungsdifferentialgleichung: $d^2\theta/dX^2 = Bi \cdot \theta(X), 0 < X < 1,$

(7) Oberflächenbedingungen: $\theta(X) = 1, X = 0, d\theta/dX = 0, X = 1.$

wo $X = x/H, 0 < x < H, F = \delta \cdot L, \Pi = 2(H + \delta),$

$$\theta(X) = \frac{t(X) - t_{\infty}}{t_b - t_{\infty}}, Bi = \frac{\alpha \cdot \Pi \cdot H^2}{\lambda \cdot F}, \delta_{min} \leq \delta \leq \infty$$

Die Lösung des Gleichungssystems (5) - (6) [3]

$$\theta(X) = \cosh[(1 - X) \cdot \sqrt{Bi}] / \cosh(Bi). \quad (8)$$

Aus dem Gesetz von Fourier und der Lösungen von (7) folgt

$$Q_{rip} = \sqrt{Bi} \cdot \frac{\lambda \cdot F}{H} \cdot (t_b - t_{\infty}) \cdot \tanh(Bi). \quad (9)$$

Analyse der erhaltenen Lösungen. Tab. 1 zeigt die Ausgangsangaben für die Berechnung nach den Formeln (8) und (9).

Tabelle 1 – Ausgangsangaben

Name	Bezeichnung	Größe
Minimal zulässige Dicke der Kühlrippe, m	d_{min}	0,005
Breite der Kühlrippe, m	L	0,4
Metallaufwand der Kühlrippe	$M\ddot{e} = \delta \cdot H$	0,004
Wärmedurchgangskoeffizient der Kühlrippe, W/(m ² · K)	a	30
Kühlrippenfußtemperatur, °C	t_b	100
Umgebungstemperatur, °C	t_{out}	20
Wärmeleitfähigkeit der Kühlrippe, W/(m ² · K)	λ	16

In Abb. 1a gibt es die Funktion für die Bestimmung der Wärmeabgabe der Rechteckkühlrippe aus Edelstahl bei $x = 0.005, 0.01 \dots M\ddot{e}/\delta_{min}$. Die Abhängigkeit der optimalen Höhe der Kühlrippe vom Metallaufwand und von dem Wärmedurchgangskoeffizienten zeigt die Abb. 1b. Die Bildunterschrift beinhaltet den *Mathcad*-Quellcode, welcher die angegebene Abhängigkeit erzeugt. Aus Abb. 1 folgt:

- Je höher die Kühlrippe, desto geringer ist ihr Temperaturmittel und desto größer ist das Temperaturgefälle über der Höhe bei gleichbleibenden Metallaufwand.

- Es gibt eine Höhe der Rechteckkühlrippe, bei der ihre Wärmeabgabe maximal wird. Mit der Reduzierung des Metallaufwandes reduziert sich die Wärmeabgabe der Kühlrippe, deren Maximum sich im Bereich der kleinen Höhe bei einem konstanten Wärmedurchgangskoeffizient befindet.

- Je geringer der Wärmedurchgangskoeffizient ist, desto größer ist die optimale Höhe der Kühlrippe und desto größer der Metallaufwand. Die Erhöhung des Wärmedurchgangskoeffizienten führt zu einer Verringerung der optimalen Höhe der Kühlrippe und ihrer Verschiebung in Richtung des geringeren Metallaufwandes.

- Die Erhöhung der minimal zulässigen Dicke der Rechteckkühlrippe kann zu dem Fall führen, dass ihre optimale Höhe bei der Größe $M\ddot{e}/\delta_{min}$ liegt.



Abbildung 1 - Illustration der Lösung der Gleichung (8) und die Abhängigkeiten der optimalen Höhe der Rechteckkühlrippe vom Metallaufwand und vom Wärmedurchgangskoeffizienten ($H := 0.25$, Given $H_{opt}(M\ddot{e}_\pi, \alpha, mat)$:= Maximize(Q, H), $M\ddot{e}_\pi := 0.002, 0.0025..0.09$)

3. Effizienz der Kühlrippen

In Abb. 2 werden die Kurven miteinander verglichen, die für die Effizienz und die maximale Wärmeabgabe der rechteckigen und dreieckigen Kühlrippe zuständig sind.

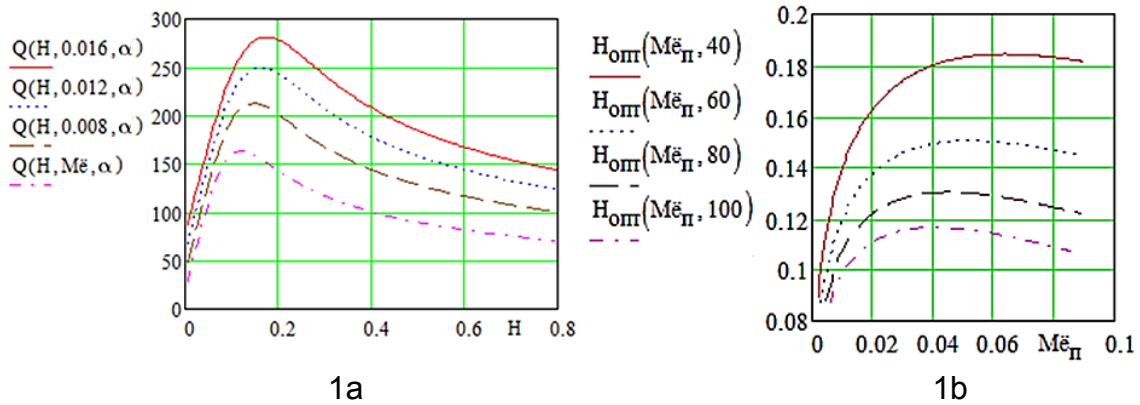

Abbildung 2 – Die Abhängigkeit der Wärmeabgabe und der Effizienz der Kühlrippe von ihrer Höhe für eine Rechteckkühlrippe mit der wärmeisolierte Rippenspitze (a), und der dreieckigen und rechteckigen Kühlrippe ohne wärmeisolierte Rippenspitze

Abb. 2a wurde aus der Bedingung abgeleitet, dass der Wärmestrom der idealen Kühlrippe sich nach folgender Formel berechnet:

$$Q_{id}(H, M\ddot{e}, \alpha, mat) = \alpha(t_b - t_{out}) \left[2 \left(\frac{M\ddot{e}}{H} + L \right) H \right],$$

und für die Wärmeeffizienz der Kühlrippe bei (3), für den Bereich $H = 0.0005, 0.001 .. M\ddot{e}/\delta_{min}$.

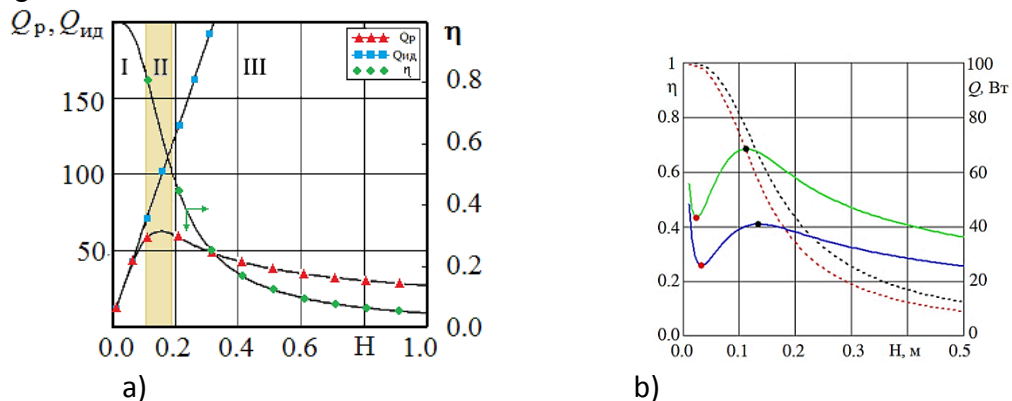
Abb. 2b berücksichtigt die bekannten Lösungen aus [3] bei Variation der Höhe der Kühlrippen und bei gleichem Metallaufwand.

Die Analyse der Kurven zeigt das Vorhandensein von drei charakteristischen Zonen. Zone I – der Bereich, in dem die Effizienz der Kühlrippe maximal ist-, aber bei kleinem - Wärmestrom. Zone II – der Bereich des maximalen Wärmestroms mit einer Effizienz zwischen 0,6-0,8. Und Zone III – der Bereich geringer Effizienz und geringen Wärmestroms.

Die Zone II ist die bevorzugte bei der Wahl der Höhe der Kühlrippe. Bei der Frage der Kühlrippenoberfläche-, sollte man alle Faktoren berücksichtigen, die den Wärmeaustausch beeinflussen-, und nicht versuchen, die Oberfläche maximal zu entwickeln oder die Effizienz der Kühlrippe mittels des Ausdrucks (3) zu steigern.

Darüber hinaus zeigt die Qualitätsprüfung, dass die Effizienz einer Rechteckkühlrippe mit wärmeisolierter Rippenspitze man nach der Formel (3) bestimmen kann, wenn man glaubt, dass ihr Zähler die maximale Größe des Wärmestroms enthält. Eine Alternative zur Gleichung (3) könnte der Ausdruck (10) sein, welcher bei Multiplikation die Formel (3) in ihrem ursprünglichen Sinn ergibt.

$$\eta_1 = Q_r / Q_r^{max} , \eta_2 = Q_r^{max} / Q_i , \quad (10)$$

Bei der Berechnung der Wärmetauscher werden oft die empirischen Relationen für die Bestimmung des Wärmedurchgangskoeffizienten verwendet. Dabei wird vorausgesetzt, dass die Temperatur oder der Wärmestrom über der Länge des Umfangs des Kanals konstant ist. In der Realität wird diese Bedingung nicht immer erfüllt. Darüber hinaus wird in der Planungsphase die Verbindung zwischen den Parametern der Kühlrippe und der maximalen Wärmeabgabe ausdrücklich nicht berücksichtigt. In unserem Fall-, lässt uns die Berücksichtigung dieser Beobachtungen eine Methodik entwickeln, die auf der maximalen Wärmeabgabe basiert, die durch den entsprechenden Parameter der Kühlrippe aus dem Bereich der gültigen Werte und durch die Geschwindigkeit des Kühlmittels iterativ bestimmt werden kann. Dieser Umstand lässt einen Entwurf des Wärmetauschers (-Rekuperator) mit-eingestellter Leistung mit optimalem Gewicht und optimaler Größe zu.

REFERENZEN

- [1] I.A. Popow. "Die wärm-hydraulische Effizienz der perspektivischen Weisen von der Intensivierung der Wärmeabgabe in den Kanälen der Wärmeaustauschanlagen bei dem erzwungene Bewegung und bei der freie Konvektionsströmung des Wärmeträgers".: Autorreferat, 2008. 41 s.
- [2] A. S. Wlasenko, W.S. Glasov, E.D. Sergievskiy "Oberflächliche Verstärkers in Wärmetauschern" // Milchindustrie. 2009. №5. s.16-18.
- [3] Carlos Silva, Doseo Park, Egidio (Ed) Marotta, Leroy (Skip) Fletcher "Optimization of Fin Performance in a Laminar Channel Flow Through Dimpled Surfaces" - <http://heattransfer.asmedigitalcollection.asme.org/> on 03/31/2015
Terms of Use: <http://asme.org/terms> .

Contacts:

Vasilii Glazov;
Affiliation: National Research University "MPEI";
Tel: +7 926 674 97 65;
E-Mail: mamurik@bk.ru

9.ОПТИМИЗАЦИЯ И ЭФФЕКТИВНОСТЬ РЕБЕР

В.С. Глазов¹, Г.Н. Афонина², Э.А. Габдрахманов³

*Национальный исследовательский университет
(Московский энергетический институт), Москва, Россия*

¹ mamurik@bk.ru, ² gal.afonina2010@yandex.ru, ³ gabemal@mail.ru

Abstract: Приведена постановка и решение задачи оптимизации ребра. Определена область его максимальной теплоотдачи и соответствующей ей диапазон тепловой эффективности. Представлен графический материал, который может быть использован при проектировании пластинчатых теплообменников.

Keywords: ребро, оптимизация, эффективность, теплообменник.

1. Введение. Актуальность данной работы для промышленной теплоэнергетики проявляется в необходимости снижения габаритов современных теплообменных систем при одновременном повышении их энергетической эффективности.

Повышение теплопередающей способности теплообменных аппаратов можно достигнуть разными способами, если опираться на закон Ньютона-Рихмана:

$$Q = \alpha \cdot \Delta t \cdot F, \quad (1)$$

где α – коэффициент теплоотдачи, Δt – разница температур между стенкой и теплоносителем, F – поверхность теплообмена.

Увеличить коэффициент теплоотдачи (α) можно за счет интенсификации теплообмена, выбрав для этого соответствующий рельеф для теплообменной поверхности [1-2]. Повышение разности температур (Δt) между стенкой и теплоносителем не всегда возможно из-за технологических ограничений. Увеличение площади поверхности (F) является одним из эффективных способов интенсификации теплообмена, которое обычно осуществляется ребрением или ошпировкой поверхности. Существует множество ребер, форма и размер которых влияют на показатели их эффективности и величины передаваемого потока теплоты. Так, среди треугольных ребер, вогнутое параболическое ребро обладает большей эффективностью при той же массе, что и другие ребра или равной эффективностью при меньшей массе [3]. Однако, обзор публикаций, посвященных эффективности разных форм ребер, показал отсутствие (даже в пределах одной формы) работ, направленных на исследование влияния высоты ребер (при неизменной их металлоемкости) на тепловую эффективность.

Считается, что удобным параметром для расчета теплового потока от термически тонкого ребра является *коэффициент эффективности ребра*, определяемый через отношения тепловых потоков от реального и идеального ребра.

$$\eta = Q_{\text{реал}}/Q_{\text{идеал}} \quad (2)$$

Предполагается, что эти ребра имеют одинаковую форму и температуру в основании. Отличаются они друг от друга только коэффициентом теплопроводности, который у идеального ребра бесконечно большой. Так,

для прямого прямоугольного ребра с теплоизолированным торцом коэффициент эффективности имеет вид

$$\eta = \tanh(\sqrt{Bi_{\text{реб}}}) / \sqrt{Bi_{\text{реб}}} \quad (3)$$

где $Bi_{\text{реб}}$ - число Био ребра, определяемое из выражения

$$Bi_{\text{реб}} = \alpha \cdot \Pi \cdot L / (\lambda \cdot F) \quad (4)$$

Здесь α – коэффициент теплоотдачи, Π – периметр ребра, L – длина ребра, λ – коэффициент теплопроводности материала ребра, F – площадь поперечного сечения ребра.

Из выражения (3) следует, что эффективность такого ребра быстро снижается с ростом числа Био. Поэтому, если коэффициент эффективности ребра мал, то может возникнуть ситуация, когда поверхность без ребра отдает тепло лучше, чем при его наличии [4].

Качественная оценка теплоотдачи прямоугольного ребра говорит о том, что, с одной стороны, теплоотдача должна возрастать с увеличением высоты (площади теплообмена) при постоянной металлоемкости ребра, а с другой – может снижаться из-за интенсивного теплообмена между верхней частью ребра и внешней средой. В таком случае при большой высоте ребра, некоторая его часть, ближе к вершине, будет иметь температуру близкую или равную температуре внешней среды. Это приводит к нулевому теплосъему на этой части ребра и, следовательно, к неэффективному его использованию. Отсюда следует предположение о существовании таких параметров ребра, при которых теплоотдача будет максимальна и, следовательно, будет максимальна эффективность ребра, определяемая по формуле (3).

Цель и задачи работы. Цель данной работы заключается в определении связи между максимальной теплоотдачей и тепловой эффективностью прямоугольного ребра. Для достижения этой цели необходимо:

- решить задачу по оптимизации прямоугольного ребра;
- определиться с выражением, связывающим максимальную теплоотдачу ребра данной формы с его эффективностью.

2. ОПТИМИЗАЦИЯ ПРЯМОУГОЛЬНОГО РЕБРА

Постановка и решение задачи. Необходимо определить параметры прямоугольного ребра, обеспечивающие максимальную теплоотдачу при заданной его металлоемкости и ограничении на минимально допустимую толщину ребра.

Математическая модель задачи оптимизации имеет следующий вид:

- Целевая функция: $Q_{\text{реб}} \rightarrow \max$ (5)

- Ограничения:

$$\text{ДУТ: } d^2\theta/dX^2 = Bi \cdot \theta(X), 0 < X < 1, \quad (6)$$

$$\text{ГрУсл: } \theta(X) = 1, X = 0, \quad d\theta/dX = 0, X = 1. \quad (7)$$

где $X = x/H$, $0 < x < H$, $F = \delta \cdot L$, $\Pi = 2(H + \delta)$,

$$\theta(X) = \frac{t(X) - t_{\infty}}{t_b - t_{\infty}}, \quad Bi = \frac{\alpha \cdot \Pi \cdot H^2}{\lambda \cdot F}, \quad \delta_{\min} \leq \delta \leq \infty$$

Система уравнений (5)-(6) имеет решение [3]

$$\theta(X) = \cosh[(1 - X) \cdot \sqrt{Bi}] / \cosh(Bi). \quad (7)$$

Из закона Фурье и решения (7) следует

$$Q_{\text{реб}} = \sqrt{Bi} \cdot \frac{\lambda \cdot F}{H} \cdot (t_b - t_{\infty}) \cdot \tanh(Bi). \quad (8)$$

Анализ полученного решения. В табл. 1 представлены исходные данные для расчета по формулам (7) и (8).

Таблица 1 – Исходные данные

Наименование	Обозначение	Значение
Минимально допустимая толщина ребра, м	d_{\min}	0,005
Ширина ребра, м	L	0,4
Металлоёмкость ребра	$M\ddot{e} = \delta \cdot H$	0,004
Коэффициент теплоотдачи ребра, Вт/(м ² ·К)	a	30
Температура в основании ребра, °С	t_b	100
Температура окружающей среды, °С	t_{out}	20
Коэффициент теплопроводности ребра, Вт/(м·К)	λ	16

На рис. 1а представлена функция для определения теплоотдачи прямоугольного ребра из нержавеющей стали при $x = 0.005, 0.01 \dots M\ddot{e}/\delta_{\min}$. Зависимость оптимальной высоты ребра от его металлоёмкости и коэффициента теплоотдачи приведена на рис. 1б. Здесь же дана строка из Mathcad, которая формирует указанную зависимость.

Из рис. 1 следует:

- Чем выше ребро, тем ниже его средняя температура и больше температурный перепад по его высоте при неизменной металлоёмкости.
- Существует высота прямоугольного ребра, при которой его теплоотдача становится максимальной. С уменьшением металлоёмкости снижается теплоотдача ребра, максимум которой смещается в область малых высот при неизменном коэффициенте теплоотдачи.
- Чем меньше коэффициент теплоотдачи, тем выше оптимальная высота ребра и больше металлоёмкость и, наоборот, увеличение коэффициента теплоотдачи приводит к снижению максимальной оптимальной высоты ребра и её смещению в сторону меньшей металлоёмкости.
- Увеличение минимально допустимой толщины прямоугольного ребра может привести к случаю, когда оптимальная его высота будет определяться величиной равной $M\ddot{e}/\delta_{\min}$.



Рисунок 1 - Иллюстрация решения (8) и зависимости оптимальной высоты прямоугольного ребра от металлоёмкости и коэффициента теплоотдачи ($H := 0.25$, Given $H_{\text{опт}}(M\ddot{e}, \alpha, \text{mat}) := \text{Maximize}(Q, H)$, $M\ddot{e}_n := 0.002, 0.0025 \dots 0.09$)

1. ЭФФЕКТИВНОСТЬ РЕБЕР

На рис. 2 сопоставлены кривые, отвечающие за эффективность и максимальную теплоотдачу прямоугольного и треугольного ребра.

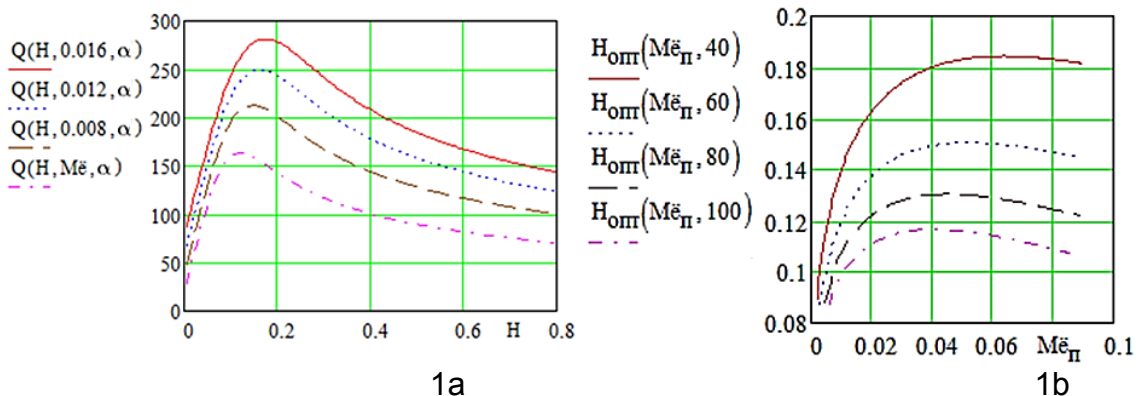

Рисунок 2 – Зависимость теплоотдачи и эффективности ребра от его высоты для прямоугольного ребра с теплоизолированным торцом (а), а также треугольного и прямоугольного ребра с не теплоизолированным торцом

Рис. 2а получен из условия, что тепловой поток от идеального ребра рассчитывается по формуле

$$Q_{ид}(H, M\ddot{e}, \alpha, \text{мат}) = \alpha(t_b - t_{out}) \left[2 \left(\frac{M\ddot{e}}{H} + L \right) H \right],$$

а тепловая эффективность ребра - по (3), для диапазона $H=0.0005, 0.001 \dots M\ddot{e}/\delta_{min}$.

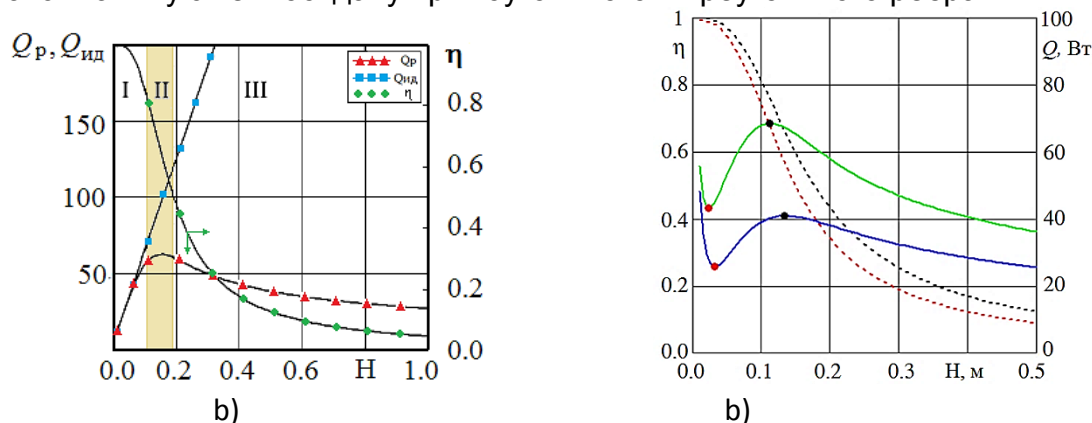
Рис. 2b получен с учетом известного решения [3] при вариации высоты ребер и постоянной их металлоемкости.

Анализ полученных кривых указывает на наличие трёх характерных зон. Зона I – область, в которой эффективность ребра максимальна, но тепловой поток небольшой. Зона II – область максимального теплового потока с эффективностью в пределах 0,6-0,8. И зона III – область низкой эффективности и небольшого теплового потока.

Таким образом, зона II является предпочтительной при выборе высоты ребра. Поэтому, подходя к вопросу оребрения поверхности, стоит учитывать все факторы, влияющие на теплообмен, а не стремится максимально развить поверхность или увеличить эффективность ребра согласно выражению (3).

Кроме того, из сопоставительного анализа следует, что эффективность прямоугольного ребра с теплоизолированным торцом можно по-прежнему определять по формуле (3) если полагать, что её числитель содержит максимальную величину теплового потока. Альтернативой формуле (3) могут служить выражения (8), которые при перемножении дают формулу (3) в её первоначальном смысле.

$$\eta_1 = Q_p/Q_p^{max}, \quad \eta_2 = Q_p^{max}/Q_{ид}, \quad (8)$$

При расчете теплообменных аппаратов часто используются эмпирические соотношения для определения коэффициента теплоотдачи. При этом предполагается постоянство температуры или теплового потока по периметру канала. В действительности это условие не всегда выполняется. Кроме того, на этапе проектирования в явной форме не учитывается связь между параметрами ребра и максимальной теплоотдачей. В нашем случае, учет этих замечаний позволил

разработать методику, основанную на максимальной теплоотдаче, которая обеспечивается соответствующими параметрами ребра из области допустимых значений и скоростью теплоносителя, определяемой итерационно. Данное обстоятельство позволяет спроектировать рекуператор заданной мощности с оптимальными массогабаритными характеристиками.

СПИСОК ЛИТЕРАТУРЫ

1. Попов И.А. Теплогидравлическая эффективность перспективных способов интенсификации теплоотдачи в каналах теплообменного оборудования при вынужденном и свободноконвективном движении теплоносителей: автореф. ... док. техн. наук.- К.: КАИ, 2008. 41 с.
2. Власенко А.С., Глазов В.С., Сергиевский Э.Д. Поверхностные интенсификаторы в теплообменниках//Молочная промышленность. 2009. №5. С.16-18.
3. Carlos Silva, Doseo Park, Egidio (Ed) Marotta, Leroy (Skip) Fletcher "Optimization of Fin Performance in a Laminar Channel Flow Through Dimpled Surfaces" - <http://heattransfer.asmedigitalcollection.asme.org/> on 03/31/2015
Terms of Use: <http://asme.org/terms> .

10. ASH OF THERMAL POWER PLANTS: ENVIRONMENTAL AND ECONOMIC ASPECTS OF APPLICATION IN CONSTRUCTION

Nazirov R.A1, Durov A.A2, Mettke A.3

^{1,2}School of Engineering and Construction, Siberian Federal University,
Krasnoyarsk 660041, the Russian Federation

³Arbeitsgebiet Bauliches Recycling, Brandenburg University of Technology
Cottbus – Senftenberg

Abstract: A low level of fly ash recycling is a significant problem of energy generation in the Russian Federation. Only 16% of annually generated fly ash is recycled. This problem is particularly relevant for the Krasnoyarsk Krai – the territory on which 8 large coal-fired power plants (CPP's) are located, generating more than 1.2 million tons of ash and slag waste per year. At the same time, fly ash is known to have enhanced concentrations of naturally occurring radioactive materials such as ^{226}Ra , ^{232}Th and ^{40}K . In the present work enhanced radioactivity of fly ash samples collected from CPP's using coals from Kansk-Achinsk coal basin, has been measured. Effective specific activity of natural radioactive nuclides varies from 111 to 218 Bq·kg⁻¹. It is found, that the fly ash produced from coals of Kansk-Achinsk coal basin may be used in building materials according to national standards of the Russian Federation. Economic efficiency of the use of fly ash as a cement supplementation in concrete was reviewed.

Keywords: fly ash, radioactivity, naturally occurring radioactive materials, coal-fired power plants, recycling, construction, concrete

Introduction

Coal provides 30% of global primary energy needs and generates over 41.1% of the world's electricity [1], in particular 16% in the Russian Federation and about 42% in Germany [2]. Low level of fly ash recycling is an important problem of energy generation in the Russian Federation. Currently, the Russian energy sector operates 135 CPP's, which use 238 ash dumps with a total area of 28 thousand hectares. According to the Ministry of Energy of Russia about 1 billion 70 million tons of ash is accumulated in ash dumps [3]. Over 22 million tons of ash was produced in Russia in 2014. Only 16% (3.7 million tons) of it was recycled [3] (compared to 70% in the US, 80% in China, and 100% in Germany [4]) and the situation with very low utilization of ash remained unchanged for years. The unit cost of operation of ash dump, environmental fees and other costs amount from 5% to 7% of the total cost of energy production in CPP's [4].

One of the most convenient ways of recycling coal combustion products such as fly ash is to use it in technological process of concrete production. These by-products include fly ash, which can be used to replace or supplement cement in

concrete. Recycling coal combustion products in this way is beneficial to the environment.

Statement of the scope of the study

Russian national standards regulate use of fly ash and slag mixture in the manufacture of various building materials (cement, silica and clay brick, concrete mixes, porous aggregates for concrete) and in the construction of roadbed, road bases, and coatings of highways. The main standards are the following:

- GOST 25818-91 «Thermal plant fly-ashes for concretes. Specifications» (with changes from 17.05.2000);
- GOST 25592-91 «Mixes of fly-ash and slag of thermal plants for concretes. Specifications» (with changes from 17.05.2000);
- NRB-99/2009. SanPiN 2.6.1.2523-09 «Radiation safety standards. Sanitary rules and regulations».

In accordance with the standards for use in concretes fly ash is normalized by chemical composition (CaO, MgO, SO₃, Na₂O), weight loss on ignition (%), moisture (%), the specific surface area (m²·kg⁻¹), and grain composition.

The main hygienic factor to rationing for the fly ash is the total value of the specific effective activity of natural radionuclides A_{eff} .

Depending on the value of A_{eff} indicator fly ash is allowed to use for the following purposes:

- for the production of materials, products and structures used for construction and reconstruction of residential and public buildings with A_{eff} to 370 Bq·kg⁻¹;

- for the production of materials, products and structures used for the construction of industrial buildings and facilities, as well as the construction of roads within the territories of settlements and areas promising development when A_{eff} varies from 370 Bq·kg⁻¹ to 740 Bq·kg⁻¹.

The specific activity of natural radionuclides contained in the fly ash is determined by gamma-spectroscopy according to GOST 30108-94 «Building materials and elements. Determination of specific activity of natural radioactive nuclei».

In accordance with Russian standards, waste ash and slag are the fifth class of hazard (safety net), which allows their use in the manufacture of building materials.

Materials and Methods

In this study, parameters of fly ash, which was produced by combustion of brown coals of Irsha-Borodino, Nazarovo and Berezovsky deposits (total reserves of more than 21.6 billion tons [5]), were measured in order to determine its suitability for use as a component of concrete mixture.

These coal deposits are included in one of the largest coal deposits in the world - Kansk-Achinsk coal basin (22% of the explored coal reserves in Russia, 112 billion tons) [6]. The largest consumers of Kansk-Achinsk coals are CPP's placed in Krasnoyarsk, Abakan, Achinsk, Kansk, Minusinsk, and Nazarovo GRES, Krasnoyarsk GRES-2 and Berezovskaya GRES. Moreover, in small towns and villages these coals are used as a boiler fuel.

About 1.2 million tons of slag waste is produced in the region annually, which is placed on 25 organized slag disposals [7].

From 7 to 25 representative samples of each type of coal (depending on its origin) were prepared to carry out laboratory tests. These samples were dried to constant weight and placed in Marinelli vessels to meet the requirements of GOST 30108-94. Containers were sealed and equilibrated for 14 days in order to obtain a radioactive equilibrium of natural radioactive nuclides.

Specific effective activity of natural radionuclides was determined in accordance with GOST 30108-94 «Building materials and elements. Determination of specific activity of natural radioactive nuclei» as the total effective activity of the main radioactive nuclides of natural origin contained in building materials: ^{226}Ra , ^{232}Th and ^{40}K , taking into account their biological effects on the human body by the formula (1):

$$A_{\text{eff}} = A_{\text{Ra}} + 1,31A_{\text{Th}} + 0,085A_{\text{K}} \quad (1)$$

Where A_{Ra} , A_{Th} and A_{K} are the activity concentrations of the ^{226}Ra , ^{232}Th and ^{40}K in $\text{Bq}\cdot\text{kg}^{-1}$, respectively.

Gamma spectrometric measurements were carried out at the laboratory of physical and chemical methods of analysis of Siberian Federal University using verified scintillation spectrometer (with a special program package).

Results

As a result of a series of experiments statistical indicators of distribution of specific effective activity of fly ash were calculated.

Table 1. Fly ashes from the main deposits of the Kansk-Achinsk coal basin are largely heterogeneous in the radiation factor. Most radioactive fly ash is produced by combustion the coal from Berezovsky deposit, the least – Irsha-Borodino.

Table 1. Statistical indicators of distribution of specific effective activity of fly ash produced by coal-fired power plants in the Krasnoyarsk Territory, $\text{Bq}\cdot\text{kg}^{-1}$

Indicators	^{226}Ra			^{232}Th			^{40}K			A_{eff}		
	I-B*	B**	N***	I-B	B	N	I-B	B	N	I-B	B	N
Average	53.1	189	140	35.7	16.4	38.1	102	90.2	156	111	218	203
Median	54.8	97.4	125	31.4	5	38	103	163	178	110	162	192
Standard deviation	23.0	242	105	13.2	17.7	3.8	54.0	78.6	61.4	34.3	238	110
Minimum	5	5	5	18.6	5	33.1	35	35	35	42.7	14.5	53.3
Maximum	101	963	337	61.5	63.6	42.8	209	294	215	167	981	408
The maximum value with a probability of 0.95	101	800	335	58	63.4	46	211	264	301	179	800	412

* - fly ash from Irsha-Borodino deposit

** - fly ash from Berezovsky deposit

*** - fly ash from Nazarovo deposit

Statistical indicators of A_{eff} distribution in fly ashes and mixtures of ash produced by CPP's, using Kansk-Achinsk brown coal, are defined. The largest excess of rated value of A_{eff} is observed in fly ash of Berezovsky coal deposit (from 14,5 $\text{Bq}\cdot\text{kg}^{-1}$ to 981 $\text{Bq}\cdot\text{kg}^{-1}$ with average value of 218 $\text{Bq}\cdot\text{kg}^{-1}$).

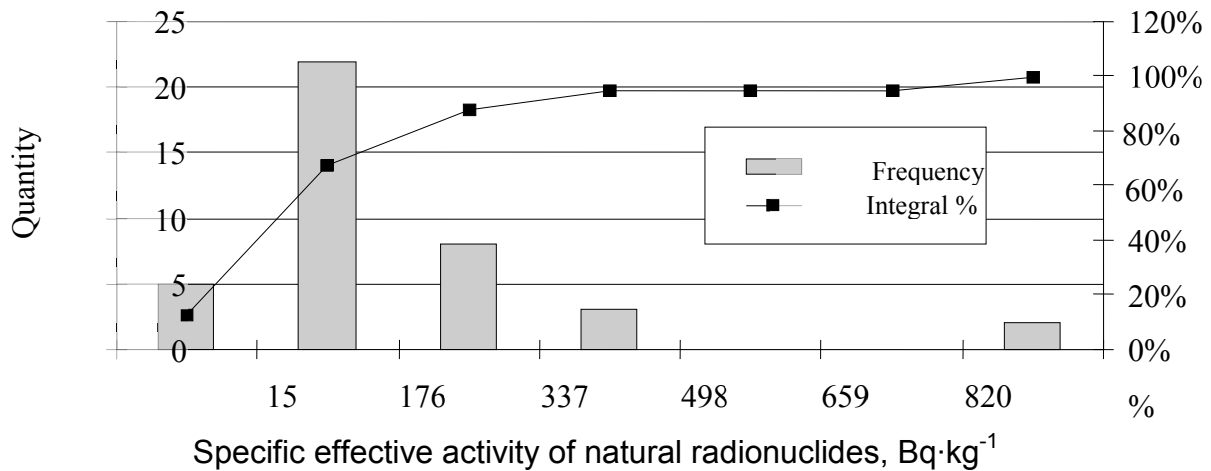

Fig. 1. Histograms of the distribution of total value of the specific effective activity of natural radionuclides in fly ashes produced by combustion brown coal from Berezovsky deposit

Specific effective activity of fly ash and slag of Nazarovo GRES (fires coals of Nazarovo deposit) is about the same, with the same waste from other regions. Ash waste of Krasnoyarsk CPP's, burning Irsha-Borodino coal, have the lowest effective specific activity, which is slightly higher than the average value of A_{eff} for concrete: from 42,7 $\text{Bq}\cdot\text{kg}^{-1}$ to 167 $\text{Bq}\cdot\text{kg}^{-1}$ with average value of 111 $\text{Bq}\cdot\text{kg}^{-1}$.

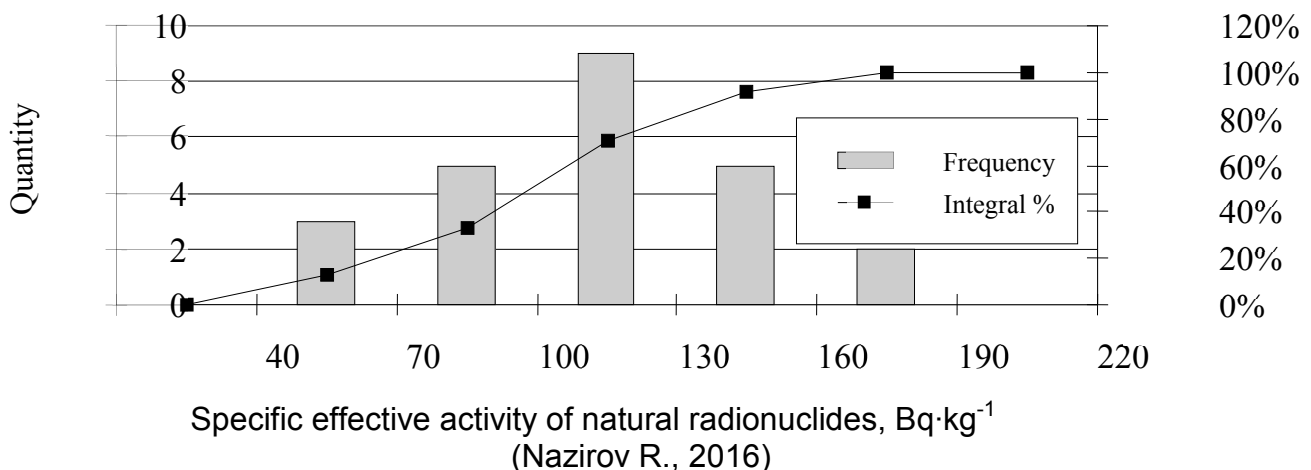

Fig. 2. Histograms of the distribution of total value of the specific effective activity of natural radionuclides in fly ashes produced by combustion of brown coal from Irsha-Borodino deposit

Production of concrete with a given class of strength is possible only with simultaneous replacement of the cement and sand by fly ash. It was determined experimentally that 10% of cement and 5% of sand in concrete mixture can be replaced by fly ash [8]. The introduction of fly ash into the production cycle does requires insignificant costs for reconstruction of an enterprise, because physical and mechanical properties of fly ash is similar to cement. Existing

manufacturing equipment for warehousing, storage, feeding and dosage of fly ash can be used in the process.

Conclusions

- The ash from burning coal of Kansk-Achinsk basin can be applied for use in the production of building materials by its radiological properties.
- In the present study revealed a characteristic of fly ash of Kansk-Achinsk coals lies in the fact that A_{eff} of these materials is formed by 46 ... 88% ^{226}Ra and only 2 ... 8% ^{40}K .
- Analysis of the available data in the literature and our own research [8] results leads to the conclusion that the definition of specific effective activity in the ash wastes with high content of unburnt coal, does not provide information on the actual values of A_{eff} in the mineral component. At the same time radionuclide composition of mineral component of coal ash waste radioactivity will be largely determined by the size of the loss on ignition. In addition, slag waste of brown coals has a remarkable feature – it is hydraulically activated.
- Use of fly ash in the concrete mix is economically feasible with a price of fly ash lower than the price of sand
- **Table 2.** Depending on quantitative index of value of the specific effective activity of natural radionuclides A_{eff} all of the convenient building materials could be divided in four groups, wherein the fly ash can be classified as low and medium-contains of natural radioactive nuclides.

Table 2. Classification (association) of multidimensional grouping of statistical data on the content of natural radioactive nuclides and specific effective activity of construction materials and raw materials by multi-dimensional medium

Class	Materials	Classification attributes in content NRN		
		Values of quantitative indicators		Qualitative characteristics
		Number	$A_{\text{eff}}, \text{Bq}\cdot\text{kg}^{-1}$	
I	Gypsum, asbestocement, lime	up to 0.52	up to 54.2	low
II	Ash and slag mixture, cement, gravel, expanded clay, sand, heavy concrete, gravel, loam, mineral wool	from 0.52 to 1.14	from 54.2 to 120	low and medium
III	Clay, brick	from 1.14 to 1.45	from 120 to 153	increased
IV	Expanded clay, tile ceramic, fly ash	from 1.45	from 153	high

References

- [1] Coal facts 2015. World coal association. London, 2016.
http://www.worldcoal.org/file_validate.php?file=Coal%20Facts%202015.pdf.
- [2] Coal matters: coal and electricity generation. World coal association. London, 2012.
[http://www.worldcoal.org/file_validate.php?file=coal_matters_3 -
coal_and_electricity_generation\(16_05_2012\).pdf](http://www.worldcoal.org/file_validate.php?file=coal_matters_3_-_coal_and_electricity_generation(16_05_2012).pdf).
- [3] Fridrikh B. Money lies under your feet: Russia solves the problem of ash waste. *Power and Industry of Russia 2016*; 285. Saint Petersburg: Publishing House "EPR". <http://www.eprussia.ru/epr/286/3862671.htm>
- [4] Kozhukhovskii I. Raw materials: Solid residue. *Russian Business Newspaper - Industrial Review 2011*; 822.
<https://rg.ru/2011/11/08/othody.html>
- [5] Bykadorov V., Ozerski A. Geological and industrial atlas of Kansk-Achinsk coal basin. Krasnoyarsk: Univers, 2001.
- [6] Gavrilin K. Ozerski A. Kansk-Achinsk coal basin. Moscow: Nedra, 1996.
- [7] Interregional Association of economic interaction of subjects of the Russian Federation "Siberian Agreement". Report on the joint meeting of the Coordinating Council of Siberian energetics, energy saving and energy efficiency of the Interregional Association "Siberian Agreement" and the Russian-Indian Working Group on the safe use and disposal of fly ash of thermal power plants, 2012.
<http://www.sibacc.ru/upload/iblock/cec/05.pdf>.
- [8] Nazirov R. Development of scientific bases and methods of producing building materials with predetermined radiation-ecological properties. *Doct. diss.* Krasnoyarsk, 2003. 500 p.
<http://www.dissercat.com/content/razvitie-nauchnykh-osnov-i-metodov-polucheniya-stroitelnykh-materialov-s-zadannymi-radiatsio#ixzz4OjA9uJPZ>

Contacts:

Main Author; Durov A.A.

Affiliation: School of Engineering and Construction, Siberian Federal University, Krasnoyarsk 660041, the Russian Federation

Tel: +7-913-183-66-99

E-Mail: ¹nazirovra@gmail.com, ²alexanderdurov@yandex.ru,

³mettke@b-tu.de

11. IMPROVING EFFICIENCY OF EXTERNAL WALLING DESIGN SOLUTIONS (ESPECIALLY FOR SEVERE CLIMATIC CONDITIONS)

1 Polina Lyamzina, 2nd year post-graduate student

¹Siberian Federal University, Krasnoyarsk 660041, the Russian Federation

Abstract: Actual problem of architecture and construction is improvement of hydrothermal conditions of the residential building components with the increased thermal performance. Moisture accumulation in multilayer enclosing structures of buildings reduces their thermal insulation properties and has destructive effect on the building structure during maintenance. The evaluation of hydrothermal performance of framed wood wall construction of low-rise buildings with outer layer from wooden paneling with use cement wood products is presented in the paper. The zone of the possible condensation was determined by the Fokin's method that based on the model of water vapor diffusion. It was found that the zone of the possible condensation is located on the corner joint. The most simple and effective way to eliminate condensation is the use of high thermal conductivity materials (e.g. aluminum inserts). Calculation is shown that the use of aluminum panels has impact on moisture conditions of external walls, removing a moisture gain in a design during moisture accumulation.

Keywords: *energy efficiency; moisture conditions; maximum moisture; enclosing structure; framed wood wall; vapour permeability; moisture potential; high thermal conductivity materials.*

At the present time special attention is paid to the introduction of the concept of sustainable development and sustainable construction throughout the life cycle of buildings (including the increase life cycle of building, energy saving, improve the quality of building materials, etc.). Particularly actual problem of architecture and construction is improvement of hydrothermal conditions of the residential building components with the increased thermal performance. Moisture accumulation in multilayer enclosing structures of buildings reduces their thermal insulation properties and has destructive effect on the building structure during maintenance. This is the reason that frame structures are widely used in low-rise building construction.

The object of research is the multilayered external wall that composed of wooden load-bearing frame, a heat insulating layer (cement wood) and panels of chipboard, connected to the frame in one piece and forming a box-shaped section [1] (Figure 1).

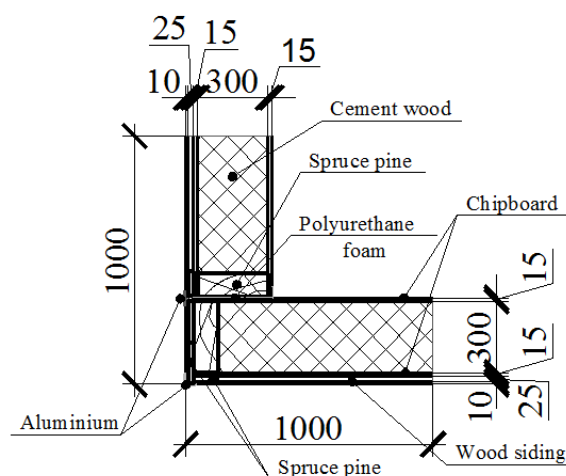

Fig. 1. Design scheme of external wall

Moreover an important component of building protection is to provide the necessary moisture barrier properties of building elements. Moisture protection is required to improve thermal performance, reliability, durability and service characteristics of building envelopes [4, 6].

The calculations were carried out for low-rise residential building in Krasnoyarsk (using Comsol Multiphysics 3.5 software). Humidity conditions of indoor and outdoor air are dry. Design thermophysical characteristics of materials of external walls are presented in table 1 [2].

Table 1. Design thermophysical characteristics of materials

Material name	Dry density ρ_0 , kg/m ³	Coefficient of thermal conductivity λ_h , W/m·°C	Vapor permeability coefficient μ , kg/m·s·Pa
Cement wood	500	0,15	$3,06 \cdot 10^{-11}$
Aluminium	2600	221	0
Spruce pine (across the grain)	500	0,14	$1,67 \cdot 10^{-11}$
Chipboard (sheeting)	1000	0,23	$3,33 \cdot 10^{-11}$
Air layer	-	0,188	-
Polyurethane foam	80	0,042	$1,39 \cdot 10^{-11}$
Wood siding	500	0,14	$1,67 \cdot 10^{-11}$

Design boundary conditions are presented in table 2. The calculation to realization of health-related requirements is made for limit state of the coldest five days period (with probability 0,92) and calculation to moisture condensation – of the most cold month of year (January) [3].

Table 2. Boundary conditions (for Krasnoyarsk climate)

Indicator name	Units of measurement	Indicator value
Temperature:		
Indoor air	$t_{int}, ^\circ\text{C}$	+20
Outdoor air	$t_{ext}, ^\circ\text{C}$	-37
- to calculation to realization of health-related requirements		-16
- to calculation of the moisture condensation		
Water vapours partial pressure:		
Indoor air (at 50% air humidity)	e_{int}, Pa	1170
Outdoor air	e_{ext}, Pa	140
Coefficients of heat transfer:		
inner surface of the wall	$\alpha_h^{si}, \text{W/m}^2 \cdot ^\circ\text{C}$	8,7
outer surface of the wall	$\alpha_h^{se}, \text{W/m}^2 \cdot ^\circ\text{C}$	23
Coefficients of moisture transfer:		
inner surface of the wall	$\alpha_v^{si}, \text{kg/m}^2 \cdot \text{s} \cdot \text{Pa}$	$25 \cdot 10^{-9}$
outer surface of the wall	$\alpha_v^{se}, \text{kg/m}^2 \cdot \text{s} \cdot \text{Pa}$	$75 \cdot 10^{-9}$

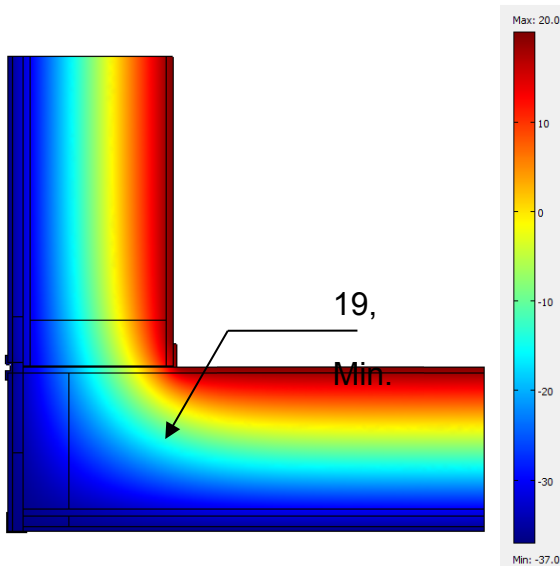

Fig. 2. The distribution of temperature fields

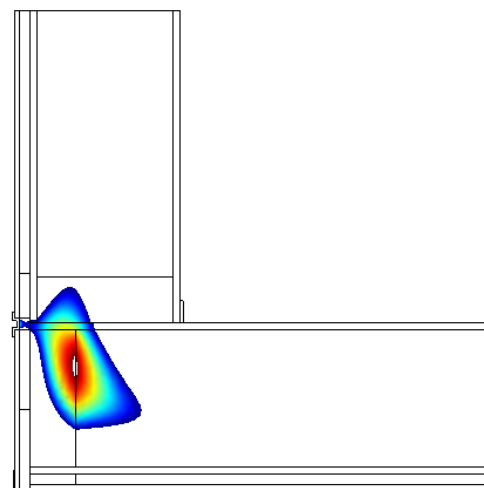

Fig. 3. Zone of the possible moisture condensation

The zone of the possible moisture condensation is determined by the method of K. F. Fokin [10] that based on the model of water vapor diffusion on the model of water vapor diffusion. This calculation method is widely used because of its simplicity and clarity of physical models and low complexity.

The condition for condensation is the following :

$$e \geq E, \quad (1)$$

where e – partial pressure of water vapor in the pores of the materials;
 E –partial pressure of saturated water vapor.

Calculation on the condensation of building envelope on the condensation produced in the following sequence. To determine the distribution of temperature $t(x)$ in the cross section of the structure (figure 2). Then to determine the distribution of partial pressure of saturated vapor $E(x)$. After that the distribution of water vapour partial pressure $e(x)$ is calculated. Find the points x where the condition (1) is satisfied. This is the zone of condensation in the building envelope (figure 3).

The **saturated** water vapors partial pressure is determined according to p. 8.6 [2]:

$$E = 1,84 \cdot 10^{11} \exp\left(-\frac{5330}{273 + t}\right) \quad (2)$$

High thermal conductivity materials (in particular aluminum inserts with a width 300 mm and 5 mm thick) were used to prevent condensation in the building envelope and to improve temperature-humidity conditions in corner joints of building structures.

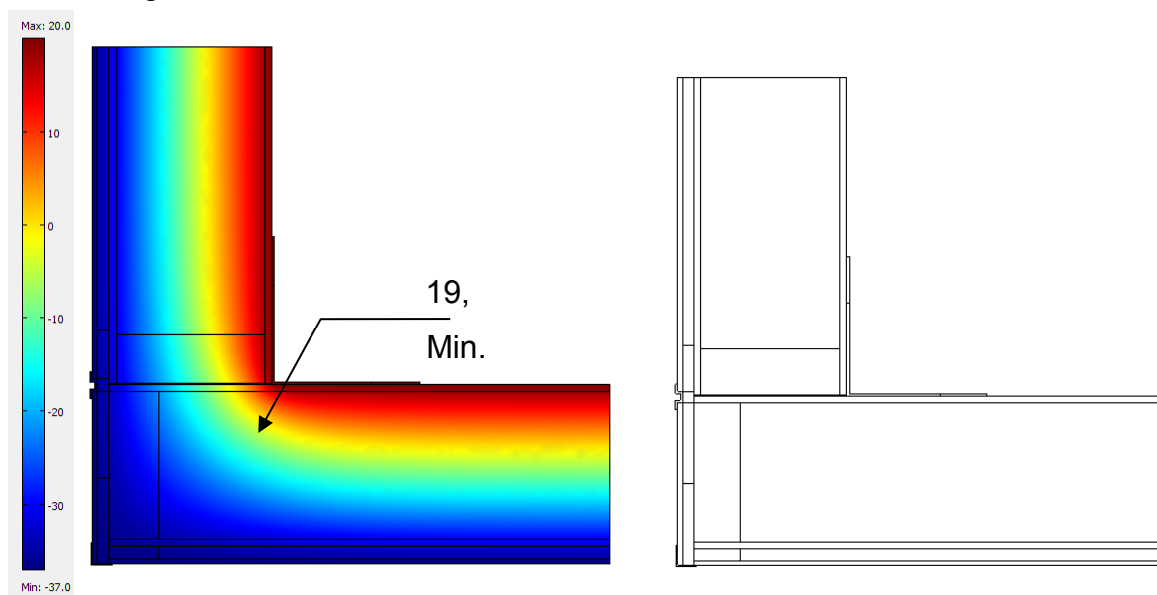

Fig. 4. The result of applying the aluminum insert:
 a) the distribution of temperature fields
 b) the lack of moisture condensation's zone

Calculation is shown (figure 4) that the use of aluminum panels has impact on moisture conditions of external walls, removing a moisture gain in a design during moisture accumulation.

The further work to research the thermophysical characteristics of materials and structures will be continued (for example, for more severe climate such as in Dixon). Also it is supposed to determine the real values of the coefficient of thermal conductivity of building materials with allowance for moisture.

References

1. Y. A. Dykhovichny, Chapter 2 “Details of the buildings” Book 1. Architectural design of low-rise residential buildings – 2nd ed. – Moscow, 2006 (rus);
2. SP 50.13330.2012 “Thermal Protection of Buildings”. The updated edition of SniP 23-02-2003 (rus);
3. SP 131.13330.2012 “Building Climatology”. The updated edition of SNIP 23-01-99 (rus);
4. Korniyenko S.V. Engineering evaluation of humidity of exterior walls. Internet-Vestnik VolgGASU. 2015. № 1 (37). Pp. 19. (rus);
5. Korniyenko S.V., Vatin N.I., Gorshkov A.S. Assessment of moisture conditions of walls with facade’s thermoinsulation composite systems with external mortar layers. Construction of Unique Buildings and Structures, 2016, 6 (45), Pp. 34-54 (rus);
6. Shoykhet B. M. Regulation of the design characteristics of thermal insulation materials in building envelopes. Energysaving. 2010. №8. Pp. 66-69 (rus);
7. Korniyenko S.V., Vatin N.I., Petritchenko M.R., Gorshkov A.S. Evaluation of hygrothermal performance of multilayered wall design in annual cycle. Construction of Unique Buildings and Structures, 2015, 6(33), Pp. 19-33 (rus);
8. Maltsev A.V., Energy saving walling using local materials at varied parameters of heat and mass transfer: thesis of candidate of Engineering – Penza, 2014 (rus);
9. Kiselev I. Y., Empirical equations describing the sorption isotherms of building materials at positive and negative temperatures. Herald of the Department of building Sciences RAACS, 2010, №14 (2), Pp. 87-93 (rus);
10. K. F. Fokin, Heat engineering of building’s envelope – 5th ed.- Moscow, 2006 (rus).

Contacts:

Russia, 660041, Krasnoyarsk, Pr. Svobodny, 82, Building “A”, Office 5-01

Affiliation: Department of Buildings Design and Examination of Real Estate, Civil Engineering Institute of Siberian Federal University, Krasnoyarsk, Russia

Tel: +7(391)2062756; +79131947441 (mobile)

E-Mail: lyamzina.polina@mail.ru

12. DIE VORLÄUFIGE BEWERTUNG DES KOHLENSÄURENAUSBRUCHES VON DEN IN DER RUSSISCHEN FÖDERATION TYPISCH GEBAUTEN BAUPROJEKTEN

1Maria Filonenko, 2Rashit Nazirov, 3Evgenij Peresipkin, 4Mettke A.

^{1,2,3}Sibirische Föderale Universität, Krasnojarsk, Russland

⁴Arbeitsgebiet Bauliches Recycling, Brandenburg University of Technology Cottbus- Senftenberg

In der vorliegenden Arbeit handelt es um die Bewertung des Kohlendioxid-Ausbruches von Baumaterialindustrie. Es werden die auf dem Gebiet Russlands typisch gebauten Wohngebäude behandelt. Es wird auch die Berechnung der Kohlendioxidemission von weitverbreiteten Baustoffen gezeigt. Das Ziel dieser Arbeit ist es, die Emissionsabhängigkeit der verschiedenen Auslegungstemperatur der Außenluft und Seismizität zu bewerten.

Schlüsselwörter: typische Bauprojekte, Nachhaltigkeit, Treibhausgas, Kohlendioxidemission, Zementherstellung, Baumaterialindustrie, Kohlendioxid.

«Seit einiger Zeit ist Nachhaltigkeit in aller Munde» [15]. Erstmals tauchte der Begriff in der deutschsprachigen Forstwirtschaft im Jahre 1987 auf. Er kommt bis heute zu zahlreichen Diskussionen und löst bedeutende Interesse aus. Es stehen viele umfangreiche Probleme vor „Nachhaltigkeit“, z.B. wirtschaftliche Ungleichheit, ökologische Krise usw.). Das Problem ist zweifelsohne sehr aktuell [3].

Die Nachhaltigkeit ist gemäß dem Brundtland-Bericht „eine Entwicklung, die den Bedürfnissen der jetzigen Generation dient, ohne die Möglichkeiten künftiger Generationen zu gefährden, ihre Bedürfnisse zu befriedigen“ [6].

Anthropogene Belastung steigt mit der Zersiedelung. Es führt zu einem enormen Anstieg des Ressourcenbedarfs und der rasenden Erschöpfung der nicht-erneuerbaren Ressourcen. Es wird einem Problem der Umweltverschmutzung keinen großen Raum gewidmet [7].

Insbesondere stellt sich die ständige Zunahme der zur globalen Klimaerwärmung geführten Kohlendioxidemissionen [7]. Die Kohlendioxidemission von Industrie gehört zu der anthropogenen Treibhausgasemission (weiter Emission). Der Einfluss von CO₂ ist auf den geochemischen Arbeitsgang Kohlenstoffs und das Erdklima bewiesen. Die Kohlenstofffreisetzung bei der Kohlen- und Ölföderung erhöht die Kohlendioxid- und Methankonzentration in der Erdatmosphäre [16].

Derzeit wird auf internationaler und völkischer Ebene eine intensive Entwicklungsarbeit der Rechtsgrundlagen und rechtlichen Rahmenbedingungen durchgeführt. Es wurde eine Reihe von internationalen Enten verabschiedet, die Treibgasniveau mit dem Ziel der Verminderung der Kohlendioxidkonzentration in der Lufthülle zu regeln.

Die Bautätigkeit gehört zu einer der materialaufwendigen und ressourcenintensiven Industrie Russlands. Sie nimmt etwa 40% aller Brennstoff- und Energieressourcen auf [11]. Die Hauptquelle des Kohlendioxidemissionsausbruchs ist Energiebedarf. Es bildet 44% von dem gesamten Emissionsvolumen, Industrie u.a. Bauindustrie ergibt 23% und 5% aller Kohlendioxidemissionen entfällt auf Zementherstellung [9].

Das Ziel der nachhaltigen Entwicklung in der Bautätigkeit ist Verschmutzungsverhütung von Umwelt, Verminderung von Energieverbrauch (Energieverbrauchminimierung), Abfallbeseitigung, Verminderung des Kohlendioxidemissionsausbruchs im Laufe des ganzen Lebenszyklus von den Gebäuden [13].

In unserer Arbeit wurden typische Bauprojekte von Massivhäusern in seismisch ungefährlicher (rechnerische Seismizität bis 6 Grad) Regionen Russlands bei den verschiedenen Auslegungstemperaturen der Außenluft und in seismischen Regionen (rechnerische Seismizität von 7 Grad) Regionen Russlands bewertet. Ziel der vorläufigen Bewertung ist Forschung des Kohlendioxidemissionsausbruchs in Baumaterialindustrie.

Für die Berechnung wurden die Bauprojekte von Massivhäusern mit 9 Geschossen und Fläche von 1100 bis 6000 m² bei den Temperaturen von -20 bis -45 Grad und Seismizität von 7 bis 9 Grad.

Es wurden Wichte von oft verwendeten Baustoffen bewertet: Zement, Beton (leicht und schwer, vorgefertigt und monolithisch), Ziegel, Stahl und Holzmaterialien.

Die Emission wurde von oben genannten Baumaterialien nach der Formel gerechnet

$$CO_2^{STAHL} + CO_2^{BM} = CO_2^{ZEM} + CO_2^{Vbeton} + CO_2^{Mbeton} + CO_2^{ZIEG} + CO_2^{HOLZ} + \quad (1)$$

Dabei ist CO_2^{ZEM} – Kohlendioxidemissionen von Zementherstellung, t pro m²; CO_2^{VB} – Kohlendioxidemissionen von der vorgefertigten [Betonherstellung](#), t pro m²; CO_2^{MB} – Kohlendioxidemissionen von der monolithischen [Betonherstellung](#), t pro m²; CO_2^{ZIEG} – Kohlendioxidemissionen von der Ziegelherstellung, t pro m²; CO_2^{HOLZ} – Kohlendioxidemissionen von Holzproduktion, t pro m²; CO_2^{STAHL} – Kohlendioxidemissionen von der Stahlherstellung, t pro m².

Kohlendioxidemissionen der Zementherstellung wurde nach der Formel gerechnet

$$CO_2^{ZEM} = CO_2^{Brennen} + CO_2^{Schrotung} + CO_2^{Abbrand}, \quad (2)$$

Dabei ist $CO_2^{Abbrand}$ – CO_2 – Austritt bei dem Abbrand der Rohstoffmischung, kg pro kg Klinker; $CO_2^{Brennen}$ – CO_2 – Austritt von Brennen und Schrotung, kg pro t; $CO_2^{Schrotung}$ – CO_2 – Austritt bei der Schrotung der Rohstoffmischung, kg pro kg Klinker.

[In Anlehnung an](#) die Ausrechnung [2], die Formel (2) sieht so aus

$$CO_2^{ZEM} = G_c^T \cdot \frac{CO_2^c}{100} + X_K \cdot G_{CO_2}^E + g_{CO_2} \cdot n_{KL}, \quad (3)$$

Dabei ist G_c^T – theoretischer Portlandzementrohmehlverbrauch, kg pro kg Klinker; CO_2^c – Gehalt des chemisch gebundenen Kohlendioxids im Portlandzementrohmehl, %; X_K – Kohleverbrauch für Stromerzeugung, kWh pro t; $G_{CO_2}^E$ – CO_2 – Austritt pro kWh Energie; g_{CO_2} – CO_2 – Austritt von Brennen der Kohle, kg pro kg; n_{KL} – Klinkermenge kg pro 1 kg Portlandzement 400.

Berechnung der Kohlendioxidemissionen der vorgefertigten [Betonherstellung](#) ist nach der Formel

$$(4) \quad CO_2^{V_{\text{beton}}} = CO_2^{WFB} + CO_2^{\text{Mischung}},$$

Dabei ist CO_2^{WFB} – CO_2 – Austritt bei der Warm- und Feuchtbehandlung der Rohstoffmischung t pro m^3 ; CO_2^{Mischung} – CO_2 – Austritt bei der Mischung der Rohstoffmischung t pro m^3 .

Die Formel (4) gestaltet sich weiter

$$(5) \quad CO_2^{V_{\text{beton}}} = G_{CO_2}^{WFB} \cdot G_{CO_2}^E + \frac{120}{3600} \cdot W \cdot G_{CO_2}^E,$$

Dabei ist $G_{CO_2}^{WFB}$ – 0,42 kWh pro m^3 [2]; W – Mischkapazität, kWh; 120/3600 – Rührzeit, min.

Für die Berechnung der Kohlendioxidemissionen von der monolithischen [Betonherstellung](#) wird nun CO_2 – Austritt bei der Mischung der Rohstoffmischung CO_2^{Mischung} berücksichtigt. Es wird wie nach den Formeln (4) und (5) gerechnet.

Kohlendioxidemissionen der Ziegelherstellung wurde nach der Formel gerechnet

$$(6) \quad CO_2^{ZIEG} = X_{\text{Form}} \cdot G_{CO_2}^E + X_{\text{Abbr}} \cdot g_{CO_2},$$

Dabei ist X_{Form} – Energieverbrauch für Formung von 1000 Stücken Rohziegels kWh pro Stunde; X_{Abbr} – Kohleverbrauch für Rohziegelabbrand, t pro t Stück.

Kohlendioxidemissionen von Holzproduktion wurde nach der Formel gerechnet

$$(7) \quad CO_2^{\text{HOLZ}} = G_{CO_2}^E \cdot X_{\text{DöR}},$$

Dabei ist $X_{\text{DöR}}$ – Energieverbrauch für Bauholzdörrung kWh pro m^3 .

Kohlendioxidemissionen von der Stahlherstellung CO_2^{STAHL} wurde nach [5] gerechnet.

Berechnungsergebnisse sind in den Tabellen 1 und 2, auf den Bildern 1, 2 gezeigt.

Tab 1. CO_2 -Emission von Baumaterialindustrie in seismisch ungefährlicher (rechnerische Seismizität bis 6 Grad) Regionen Russlands bei den verschiedenen Auslegungstemperaturen der Außenluft

Auslegungstemperatur der Außenluft, °C	CO ₂ -Emission für Portlandzementherstellung, t pro m ²	CO ₂ -Emission für Betonherstellung, t pro m ²	CO ₂ -Emission für Baumaterialindustrie, t pro m ²
-23	312,211	5,386	970,326
-23	280,112	5,541	881,432
-32	259,999	5,504	859,162
-40	244,062	5,287	514,810
-40	221,089	4,898	466,956
-48	184,748	4,199	414,776
-50	229,911	4,920	476,167

Tab 2. CO₂-Emission von Baumaterialindustrie in seismischen Regionen (rechnerische Seismizität von 7 Grad) Regionen Russlands

Seismizität, Grad	CO ₂ -Emission für Portlandzementherstellung, t pro m ²	CO ₂ -Emission für Betonherstellung, t pro m ²	CO ₂ -Emission für Baumaterialindustrie, t pro m ²
7	296,940	5,848	924,281
7	272,102	4,991	823,797
8	284,362	6,307	876,378
8	309,613	5,995	938,715
9	357,577	7,403	1075,901
9	446,370	7,157	1324,027



Bild 1. CO₂-Emission von Baumaterialindustrie in seismisch ungefährlicher (rechnerische Seismizität bis 6 Grad) Regionen Russlands bei den verschiedenen Auslegungstemperaturen der Außenluft



Bild 2. CO₂-Emission von Baumaterialindustrie in seismischen Regionen (rechnerische Seismizität von 7 Grad) Regionen Russlands

Nach dem Befund der Tabelle 1 wurde die Funktion vom Kohlendioxid ausstoß von Baumaterialindustrie bei den verschiedenen Auslegungstemperaturen der Außenluft aufgestellt und auf dem Bild 1 gezeigt. Daraus ersieht man, dass Kohlendioxidemission bei der Temperaturerniedrigung sinkt. Das hängt mit der Anwendung der effektiven Schichtstoffbauweisen mit der Wärmedämmschicht zusammen, die von der Dichte leicht ist.

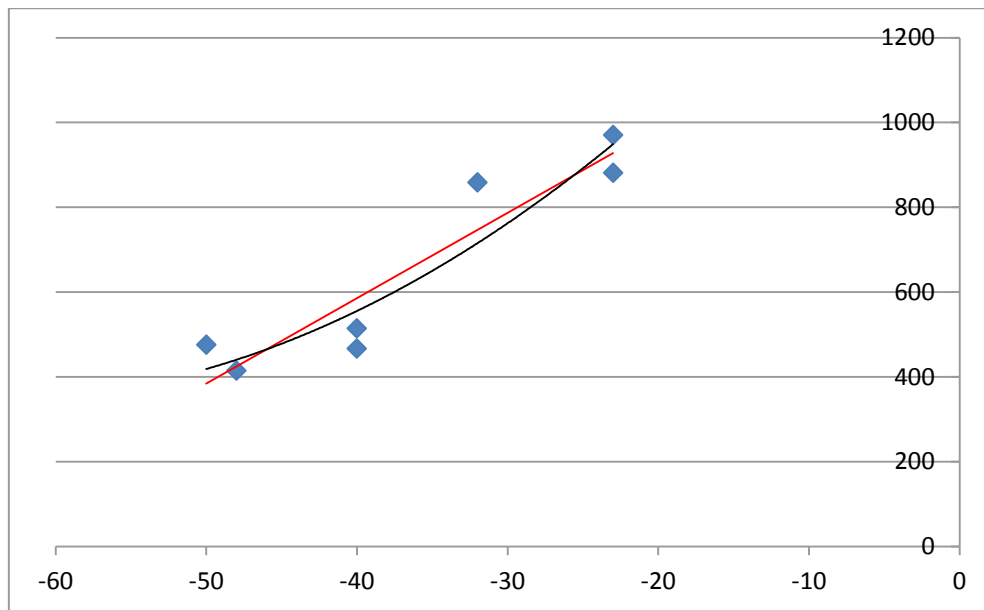
Das zweite Bild ist CO₂-Emission von Baumaterialindustrie in seismischen Regionen gezeigt. Nach dem Diagramm sieht man, dass Kohlendioxid ausstoß bei der Erhöhung der Seismizität wächst. Ein steilster Anstieg der Emission verdeutlicht von 8 БАЛЛОВ. Das ist mit der Anwendung der festen

Konstruktionen. Die Stahlbetonbauteile werden mit dem zusätzlichen Stahl bewehrt.

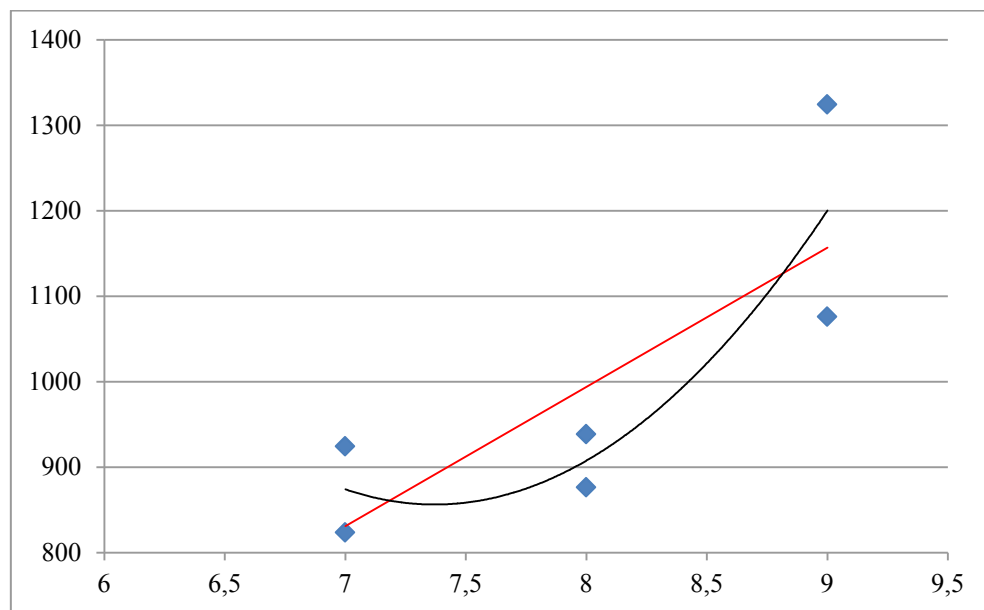
Anhand dieser Ergebnisse wird deutlich, dass Wohngebäudebau in verschiedenen Klima Russlands den entsprechenden Bedingungen nicht nur für die Gebäudeerrichtung, sondern auch für die Herstellung der Baumaterialien erfordert.

Literaturverzeichnis:

[1] А.В. Кондратьев, И.Ю. Грин, «Экологические стандарты сертификации зеленых зданий» // Том 1. Новые идеи нового века – 2014, [Электронный ресурс] - Хабаровск: ТОГУ, 2014. – Режим доступа: <http://pnu.edu.ru/media/nionc/articles-2014/140-146.pdf>.

[2] В.А. Кутйцев, Р.М. Гутвич, И.В. Корольков, *Теплотехника и тепловые установки в промышленности строительных материалов*, Москва, 1954.

[3] Д.Ю. Шаталов-Давыдов, «Этапы концептуализации устойчивого развития: анализ экономического и политического дискурсов», *Вестник Нижегородского университета им. Н.И. Лобачевского*, 2012, № 4 (1), с. 445-452.

[4] Йерун Кюзнен, «производство цемента», *Руководство ЕМЕП/ЕАОС по инвентаризации выбросов*, 2009.

[5] Л.Н.Шевелев, *Энергосбережение в черной металлургии России за 1990-2010гг. И прогнозная оценка повышения энергоэффективности металлургического производства к 2020 г.*

[6] *Международной комиссии по окружающей среде и развитию (МКОСР), «Наше общее будущее», 1987.*

[7] Н.В. Панова, «Экономика устойчивого развития», ФГАОУ ВПО Национальный исследовательский университет «Высшая школа экономики», Санкт – Петербург, 2013.

[8] Т.В. Бегун, «Устойчивое развитие: определение, концепция и факторы в контексте моногородов» [Текст] // *Экономика, управление, финансы: материалы II междунар. Науч. Конф. (г. Пермь, декабрь 2012 г.)*. — Пермь: Меркурий, 2012. — С. 158-163.

[9] Ю.В. Цыганкова, «Применение смешанных цементов в производстве сухих строительных смесей», *Технический Центр. Вакер*, 10.07.2009.

[10] Ю.С. Шлионский, «Принципы расчета при проектировании вращающихся печей», *Процессы и аппараты химических технологий [Электронный ресурс]: Новый справочник химика и технолога – Режим доступа:*

http://chemanalytica.com/book/novyy_spravochnik_khimika_i_tekhnologa/10_pr_otsessy_i_apparaty_khimicheskikh_tekhnologiy_chast_II/7227

[11] *Строительство [Электронный ресурс]: Свободная энциклопедия – Режим доступа: <http://ru.wikipedia.org>.*

[12] *Устойчивое развитие [Электронный ресурс]: Свободная энциклопедия – Режим доступа: <http://ru.wikipedia.org>*

[13] *Экологическая доктрина Российской Федерации (одобрена распоряжением Правительства РФ от 31 августа 2002 г. № 1225-р) [Электронный ресурс]: Совет Безопасности Российской Федерации – Режим доступа: <http://www.scrf.gov.ru/index.html>.*

[14] Bastian Wittstock. *Gebäude aus Lebenszyklusperspektive – Ökobilanzen im Bauwesen / Bastian Wittstock, Stefan Albrecht, Cecilia Makishi Colodel, Jan*

Paul Lindder // Wilhelm Ernst & Sohn Verlag für Architektur und technische Wissenschaften GmbH & Co. KG, Rotherstraße 21, D- 10245 Berlin. – S. 8.
[15] Christian Donath, Nachhaltige Gebäude – Planen, Bauen, Betrieben / Christian Donath, Diana Fischer, Bernhard Hauke // Bauforumstahl. Deutscher Stahlbau. Gut beraten. – 2011/- № B 105. – S. 5 – 17.
[16] Amnat Chidthaisong (Thailand), Philippe Ciais (France), Peter M. Cox (UK) Couplings Between Changes in the Climate System and Biogeochemistr.

Kontakte:

Maria Filonenko

Institut für Bauingenieurwesen

Sibirische Föderale Universität

Tel: +7-923-322-44-66

E-Mail: maria-th@mail.ru, nazirovra@gmail.com, evp143@gmail.com,

mettke@b-tu.de

13. POWER SUPPLY IN THE KRASNOYARSK TERRITORY

1Nikita Voloshenko

¹Siberian Federal University, the Russian Federation
hiki4@inbox.ru

Objectives

The objective is to describe and analyze the current situation in the Krasnoyarsk territory. The focus in the following elaboration is mainly on Hydroelectric Power Plants and Coal Power Plants because of their huge influence on the Krasnoyarsk territory

Background

The Krasnoyarsk territory is a federal subject of Russia, with its administrative center Krasnoyarsk. Krasnoyarsk territory is the largest one in the Russian Federation, covers an area of 2,339,700 square kilometers containing a population of 2,828,187 or just under 2% of its population.

The two most powerful hydroelectric plants in Russia have been on the Yenisei River, one on the Angara, and several ones are being planned. It makes Krasnoyarsk territory one of the most important producers of electric energy in Russia, and a desirable location for energy-intensive industries, such as aluminum plants.

In the Krasnoyarsk region there are 40% coal reserves of Russia. Oil reserves in the field exceed 260 million tons and it contains about 90 billion cubic meters of gas. The design capacity is 14 million tons of oil per year. Krasnoyarsk region currently holds leading positions in oil and gas production in the Siberian Federal District. Stocks of gas is 1012 trillion m³.

Krasnoyarsk territory : Power Supply

Krasnoyarsk Territory is spread from north to south for approximately 3000km. The majority of the habitants live in the southern part of the region. Because of the population density of 1,21 people/m², vast parts of the land are not inhabited and connected to the electric grid and water supply.

Private households are provided with energy which is generated by a power plant and distributed to consumers in its surroundings. These power plants extract energy from different resources, for example water, coal, oil, gas or fuel. In the Krasnoyarsk Territory there are a lot of district heating pipes, each power plant supplies the country with energy and heat. Decentralized power supply like solar panels is not very common.



Figure 1: Power substations and transmission lines

The present infrastructure in the Krasnoyarsk area leaves opportunities to optimize its efficiency. It is common, that the direct heating pipes have to be serviced for several days in summer, during that time no hot water can be delivered to the inhabitants of the houses. The system has not been changed so far.

Russia is a country with a huge amount of different natural resources like natural gas and oil, but also coal, gold and aluminium. Depending on the occurrence of natural resources, power plants are built in these regions.

As diesel fuel has to be delivered to the rural areas over long distances, the price for fuel can be very high. The wood that is used does not have to be transported over the long distances because it can be taken from the surrounding forest.

Coal

In Kansk-Achinsk coal region there is Berezovsky coal basin which produces 7 billion kWh per year. Place of construction is a coal mine. The location is

convenient because it is next to the reservoir which later came to be used for cooling the exhaust steam.

GRES (SDPS) have a case of unconventional fuel supply circuit. Brown coal is supplied to the station directly to the Berezovsky mine of the Kansk-Achinsk basin with a slash "Berezovsky-1" with two 14-kilometer open conveyors. The section performance is designed to take 55 million tons of coal per year and GRES has 4400 tons of coal per hour.

Nazarovo power station is a coal-fired power plant with an electrical power output of 1,210 MW near the town Nazarovo

There is Krasnoyarsk GRES-2 (SDPS) thermal power plant in Zelenogorsk city. The installed electric capacity is 1250 MW, the installed heat capacity is 976 Gcal / h.

Water

Krasnoyarsk region has the largest hydropower potential in Russia. One of the world's largest hydroelectric power stations are built on the Yenisei River. In the province there are 20 existing power plants.

The most powerful plants are the following:

- Sayano-Shushenskaya (23.5 billion kWh per year). It is the largest power plant in Russia and the 9th-largest hydroelectric plant in the world by average power generation. The dam supports the Sayano-Shushenskoe reservoir, with a total capacity of 31.34 km³, useful capacity of 15.34 km³ and surface area of 621 km². The arch-gravity dam is 242 metre high. It has a longitudinal section of 1,066 metres, and cross section is 25 metres, base width of 105.7 metres and maximum head of 220 metres.

- Krasnoyarsk (20 billion kWh per year). The Krasnoyarsk Dam is a 124-metre high concrete gravity dam. This reservoir has an area of 2,000 square kilometres and a volume of 73.3 cubic kilometres. It is 388 km in length, has an average depth of 36.6 m, and a depth of 105 m near the dam.

- Boguchanskaya (18 billion kWh per year). The Boguchany Dam is a 2,587 long dam of combined type, which includes reinforced concrete 774 m long gravity segment for power station building and 1,813 m long rock-fill segment with asphaltting - concrete diaphragm within all its length.

Sun

The only big plant is in Abakan with maximum of 5.2 MW and annual electricity output is 6.5 million kWh.

Conclusion

Some areas in Russia are very rural that is why a connection with a central power plant is not possible because of economical aspects. So we have to look at decentralized power supply to provide energy where it is needed. In Russia oil and gas are to be transported over long distances it costs a lot of money and is very unprofitable. There is enough radiation or wind to generate required

power in Russia especially from the point of view of cost. That is why the renewable energy is a very good option for this area.

References

Zakharenko A.A. "Krasnoyarsk lights: history of the development of electric grids and base running water in Krasnoyarsk", 2004.

Zheleznova N.G., Kuznetsov Yu. Ya., A.K. Matveev, Cherepovskiy VF. M., .: Nedra, "The reserves of coal around the world", 1983.

Stephen Bierman; Maria Kolesnikova. "Six Killed as Pipes Burst at Russia's Biggest Hydropower Plant", 2009

Rastoskuev A., "Yenisey Krasnoyarsk hydroelectric energy -. The prosperity of Russia, 1967-1997", 1997.

Website Krasnoyarsk Krai Territorial Branch of the Federal State Statistics Service <http://krasstat.gks.ru/>

Website statistics Russian electric company <https://energybase.ru/>

Website "Krasnoyarsk hydropower plant» <http://www.kges.ru/>

Website "Boguchanskaya hydropower plant» <http://www.boges.ru/>

Website "Sayan-Shusha hydropower plant" <http://www.sshges.rushydro.ru/hpp/sshges/>

Contacts: Nikita Voloshenko

Tel: +79233381219

E-Mail: hiki4@inbox.ru

14. INTRODUCTION TO THE ECO-CAMPUS ELEARNING PLATFORM

Christian Steinert¹, Eva Leptien², Dmytro Palekhov³

^{1,2,3}BTU Cottbus-Senftenberg

Abstract: University teachers complain regularly the lack of knowledge of their students. This is not a new problem. Rather, it points to an ongoing conflict between generations. [1] This conflict is based on the usual methods of knowledge acquisition. For example, teachers and students in the past have rather relied on print media due to the lack of alternatives. The development of digital media, also in higher education is rapid and it will probably be in the future. The current generation of students has therefore innately another media usage and related affinities to developed media than the previous. So the goal of the “ECO-Campus” project is to share digitized university content on sustainability with international partner universities and to establish the subject especially in the curricula of courses which traditionally pay little attention to sustainability concepts.

Keywords: *eco campus platform, video based assessment, experience based learning unit, learning platform, learning video, hyper video, spiral curriculum, flipped classroom*

Introduction

The ECO-Campus project provides the technical platform for the assembly and cooperation of universities who share a common goal: the stronger integration of the subject sustainability into their curricula. The platform is based on an internationally known open source software platform (Moodle). Thus “ECO-campus” acts as a central communication and learning platform via which the different materials are provided. Furthermore, ECO-Campus thereby sets the basis for a Green Curriculum with the option to integrate other disciplines that pursue environmentally and socially sustainable thinking, planning, action and decision making, into the curriculum. The Project is supported by the Federal Ministry for Economic Cooperation and Development (BMZ).

The platform was reimplemented at BTU last year. The system was previously supervised by Dr. Joachim Hartlik (Environmental Assessment and Quality Management)

Technical background and (responsive) design

The learning platform runs on the latest Moodle version and receives regular upgrades.

Due to the specific topic and the relationship to the BTU and its corporate design, the design of the platform has been adapted. The Moodle design

"adaptable" was used for the customizations for the newer version. Previously, the design "BCU" was implemented, but this did not support the Moodle 3. + versions.

The green tone, which is an association to the theme of the platform, comes from the design proposals of the BTU. Due to the simpler usability, the 9 tiles with the respective upper categories appear immediately after login. Each tile is provided with a picture corresponding to the theme. (See Fig. 1) After the topic has been selected, the categories are subdivided into further sub-topics.

The design adjustments also focused on the display of mobile devices (such as smartphones and tablets). About 80% of our students is learning with mobile devices such as tablet or smartphone, this has resulted in a BTU internal survey on the use of E-learning. [2] The desire of students to digital and location independent media is underlined here clearly.

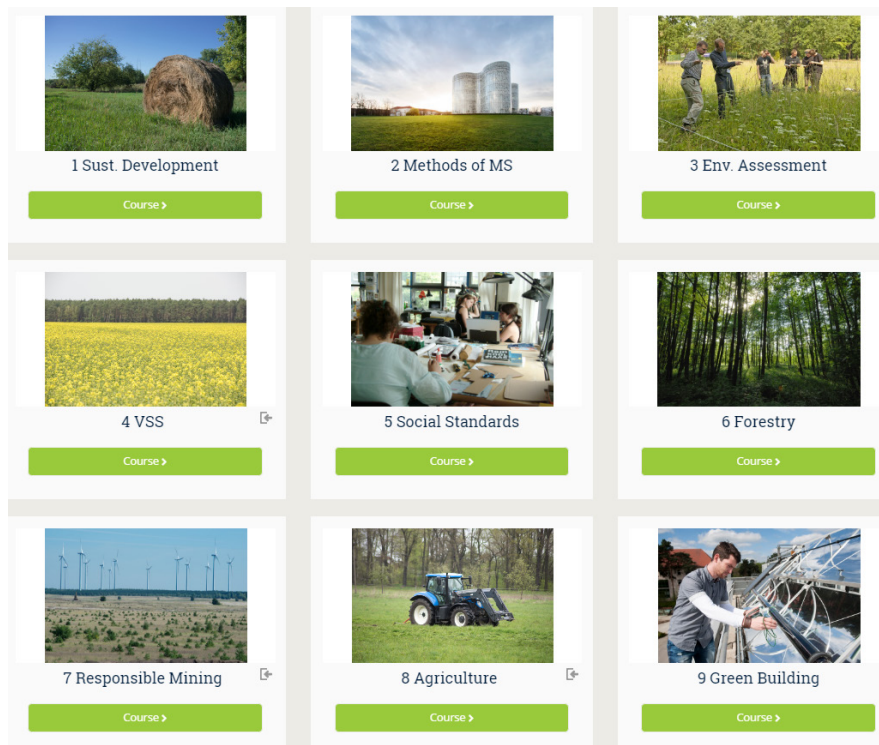

Fig. 1 Upper categories

Students of the BTU can access the contents of the platform with their BTU account. For students of partner universities, accounts are created in the ECO-campus platform with their consent and after notification of their teachers. This is due to the data protection and copyright regulations.

Audiovisual media within the platform

First of all some basic didactic considerations. In the development of instructional videos the maxim: "As short as possible and as long as necessary" applies. This is due to the average attention span of video learners. A possible target for presentation videos represent a maximum of 20 minutes. [3]

Now the question is: How we can implement this in the existing or future developed videos? One possibility would be the further subdivision of the videos in subtopics. Furthermore, a navigation can be integrated within the video, so the learner can jump more accurately to his desired contents. This is especially

relevant by an interruption or re-watching of learning videos. Moreover, the videos can be enriched by animations, so the attention can be kept more constant during each slide. Another way to hold the attention and to give the students feedback on the understanding represent videobased assessments.

Videobased assessments are normal learning videos, which stop at certain set time stamps and the learner has the possibility for himself to enter answers. There is direct feedback whether the answer is right or wrong. After a certain time or properly enter the video continues automatically. Professor Dongdong Zhang has empirically demonstrated that well-placed interactions for learning outcomes are beneficial. [4] Nevertheless, it is a balancing act. Poorly thought out or misplaced actions can bring no added value for learning outcomes. The learning process can be even hindered by false information. Another problem of learning videos represents linearity. In this case, it is meant that learning videos illustrate generally an issue with examples. Understanding the learner is tested by an interactive quiz at best, and a possible solution presented. Complete software for creating such videos are Camtasia Studio 8 or Capira Socrates.

In addition to integrated assessments, within a video integrated hypertexts are another way to enrich the existing content with interactive content. When talking about a hypertext video, is meant that within the videos are links to other pages within the platform or external sites. The internal references can be used for further navigation within the platform. The external however offer themselves to refer to other knowledge databases. Both internal links as well as external have the possibility of changing the address. This must be observed constantly. Intern, this can be as far as possible influenced, so there should be no major changes within the video. When referring to external pages whose address URL changes, the whole videos need to be reworked. The advantages of hyper videos are that they can cause curiosity and motivation as innovative technologies among students. In addition to the substantive discussion of the teaching material, media literacy- particularly in the area visual literacy - is promoted. [5] Hyper videos are particularly suitable for active, constructive learning. Hyper videos are complex media. The working and learning with hyper videos is therefore simply not always and places high demands on the cognitive skills of the user. Here is the special potential, but also potential problems such as a cognitive overload when the receptionists. Compromised may especially result from that losing users in a highly linked environment and already retrieved content may not found again.

Learning process within the platform

Based on Kolb's experiential learning approach [6], we have formed a triad of normal learning video, video-based assessment and adapted formative assessment. In the first video the students gets the theoretical access to a particular topic. Here the concrete experience and observation and reflection takes place.

In the video-based assessment the learner is activated and he shall begin to think independently abstract. The adaptive assessment consists of one or more test questions which are generated from a pool of questions randomly. The tests got a detailed feedback function.

The final phase may repeated as often as the learner wants. Due to the dynamically generated tasks and feedback the learner can demonstrate and

examine how far he has carried out the contents. Here is the phase of the active experimenting. This approach is especially useful in natural and engineering sciences. Here are many, but relatively fixed solutions, but the accuracy of the results can be easily compared. However, there is also potential transfer to the economic science, even medical and legal subjects use nowadays MCQs as audit evidence, in some disciplines. This is more difficult in the human sciences, where a high abstraction potential is required. This E-learning scenario is not only a linear structure. Learners can skip content, but return to the previous again if necessary. Also the entrance in the scenario is also not specified. (See Fig. 2)

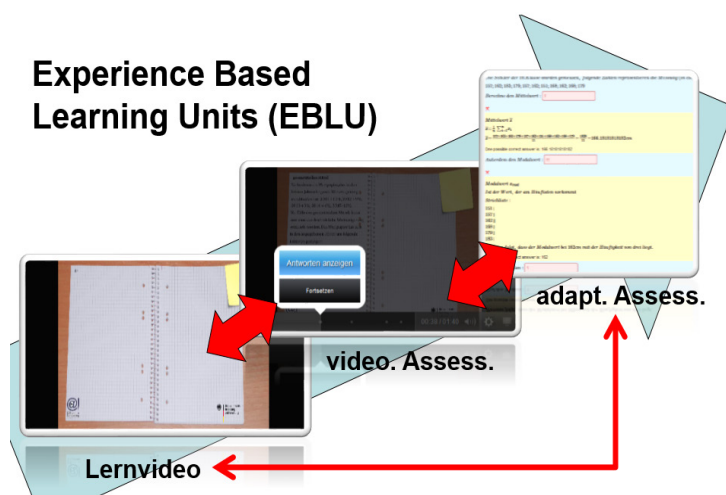

Fig. 2 Scheme Experience Based Learning Units

This scenario is quite complex built in practice. The part just described is merely the micro level. Other Experience Based Learning Units are linked together logically within a macro level. Following Bruner [7] spiral curriculum to EBLUs put together so that the result is a structure of knowledge about basic skills to more complex knowledge. However, this represents only one strand.

Furthermore, classroom sessions should still take place (at every university in ECO-Campus composite) The Units adapt accordingly so that two spirals with connections (for example, references to lecture or Elearning material), similar to the double-stranded helix of DNA are formed. For this purpose, should further logic connection (e.g.: Direct redirects within our units) be integrated, to create more cross-references to previous- or continuing related topics.

Further research

In different countries, there is a different use of digital media. Admittedly, this approach has already been partially researched in adult education and affirmed [8] (it depends strongly on the child's early education from which considered but culturally significant differences having), nevertheless arises why large open online learning platforms utilize similar concepts and materials the question.

The next research question focuses on the collaborations between different nations in the learning platform. The economist Hofstede holds various cultural dimensions between collaborations companies from different countries, which affect the successful completion of this cooperation significantly. Basically, a

collaborations is nothing but a cooperation and thus comparable to the collaborative learning. Therefore, can be detected in a first step whether similar effects as occurring from Hofstede also in collaborative learning processes. [8] If this is the case, the criteria of Hofstede can be examined of congruence or new criteria may be added.

As last research point it would be important to examine, how far the translation into the native language influences the learning success. This effect should our assumptions be very positive.

ACKNOWLEDGMENT

The author would like to thank the Federal Ministry for Economic Cooperation and Development (BMZ) for their support of the project under the direction of Prof. M. Schmidt. Furthermore, they want to thank their cooperation partner Deutsche Gesellschaft für Internationale Zusammenarbeit (GIZ). Here especially Berthold Hansmann, which also scientifically supported us in the implementation of the project.

References

- G. Wolf, „Innenansicht einer Bildungskatastrophe. Was ist faul in der „Bildungsrepublik“. *Die Politische Meinung* Nr. 519, 54-58,(2013).
- T. Falke and S. Becker, *Auswertung der Umfragen zur Lernplattform und zur Servicequalität des E-Learning Teams. Cottbus (2015).*
- S. Schön and M. Ebner, „Zeig doch mal!–Tipps für die Erstellung von Lernvideos in Lege-und Zeichentechnik.“ *Videos in der (Hochschul-) Lehre, (3), 83 (2014)* [[e-teaching.org](https://www.e-teaching.org), Hypervideo. 26 April 2016 <https://www.e-teaching.org/didaktik/gestaltung/visualisierung/hypervideo/index_html> (23.09.2016)
- R. Schulmeister, „Didaktisches Design aus hochschuldidaktischer Sicht: ein Plädoyer für offene Lernsituationen“. S.8, (2004).
- D. A. Kolb, „*Experiential learning: Experience as the source of learning and development.*“ FT press, (2014).
- J. S. Bruner, „*The process of education.*“ Harvard University Press, (2009).
- Hui Ji, „*The Impact of Culture on Preferences for E-learning Systems in Higher Education: A Comparison between China and Germany*“, Kovac: Hamburg, (2011).

Contact:

E-Mail:

¹christian.steinert@b-tu.de, ²eva.leptien@b-tu.de,

³dmytro.palekhov@b-tu.de

15. MECHANISMS OF ENHANCED INTERACTION OF REGIONAL RESOURCE AND PRODUCTION SYSTEMS

E. Mikhalkina¹, N. Kosolapova², D.Mikhalkina³

^{1,2,3} Southern Federal University
The Russian Federation

Abstract: The article presents results of modern condition water supply research in Russian Federation subjects. The paper analyzes the level of water complex development, belonging to the category of areas with water shortage, with very high and critical level of load on water objects in which there is necessity of regulation and limitation of water consumption, attracting additional sources of water supply. There are formulated proposals about operational and long-term actions, which aimed at increasing efficiency of water consumption for sustainable regions development.

Keywords: water resources, water users, resource allocation, economic systems.

New trends of Russian economy development, oriented on the formation of the non-raw model of economic growth, respectively, changed the paradigm of the strategic priorities of the regional systems, including those in the aspect of the sufficient resources provision problem of economic entities, which localize their activities within their borders. The continuing weakness of Russian economy infrastructure equipped directs strategic plans and targeted programs of Federation subjects on a more rational use of resources, first of all, basic. And determines as an important area of research the conceptions search, new models and mechanisms their effective allocation for projects implementation, which support the sustainable development of territories.

Also it is necessary to bear in mind that the relationship of the regional elements of the system appears as vertical (levels of the Russian economy hierarchy), and horizontally (between the components of the same level), a number of which play a backbone role in the macroeconomy as a whole and individual regions. It is connected with the key role of major structural units of the regional economy with independent meso-economic status. These structural units promote the development of the regional economy or constrain the ongoing dynamics, and frequently form the basic connection between leading and lagging functional zones of the territorial complex. Considerable significance is the fact, that the development of management actions regional authorities has more effective character and also has a smaller step of delay implementing management decisions in comparison with the institutional role of the federal agencies.

¹ Doctor of Economics, Professor Faculty of Economics. Southern Federal University

² Associate Professor, department of Economic Cybernetics; Candidate of Technical Sciences. Southern Federal University

³ The 3rd year student of "Economy". Southern Federal University

The active development of competitive relations in the process of resource maintenance subjects of the regional economy, determined by the new macroeconomic conditions, significantly aggravated the problem of providing regions by one of the most important types of basic resources - water resources - due to more intensive usage both for industry and agriculture, and for communal general needs. Therefore rational water consumption becoming a key factor in economic and social development of regions that affect the progress of the productive forces and the relations.[1]

Russian Federation is one of the countries with large reserves of water resources. Mean multiyear renewable water resources of Russia represent 10% of global river runoff (the 2 place in the world after Brazil), and are estimated at 4.3 ths. cubic. km per year. On the average per one person accounts for just over 30 thousand cubic meters per year, far exceeding the critical exponent, which established by United Nations, of 1.7 thousand cubic meters. per person, guaranteeing maintenance minimal needs of the population, the economy and preserving the environment.[2]

However, despite the high rate of the specific renewable water resources provision in some regions of the country, mostly in the low-water periods, there are local water shortages, manifested not only in the lack of water a certain quality to satisfy the needs of the population and the economy, but also the impossibility of saving necessary conditions for the existence of water and related ecosystems.

Lack or water resources deficiency is one of the reasons for economic damages, slowing regions economic development, social growth and environmental tensions.

So, currently the real practice tested high and increasingly growing water specific volume consumption in industry, agriculture, housing and communal services and others. In this case water exemptions volumes are becoming comparable to their presence, which leads to a deficiency of water balances. Moreover to water users water consumption limits are established on the basis of application compiled by their needs in water resources taking into account the water balance.

The complex system of economic interests implementing in the relationships and interactions of water market participants being unbalanced, does not provide the material basis for the formation of achieving overall cost-effectiveness. Consequently conceptual idea of region management water resources distribution should be not only in the modernization of water management complex territory in the broadest sense of the word, but in modernization based on innovatization links and relations of participants in this market, aimed at achieving the strategic goals, the central impulse which should specify the establishment of mutually beneficial cooperation conditions.

Targets of individual water resources consumers are at the lowest level of aggregation, target industry have a higher level of aggregation and then regional development. The main purpose of the strategic development of water management complex territory shall comply with the interests of overall economic efficiency: increasing the level of national security, the growth of national production competitiveness in the world markets, increasing the level and quality of life.

The effectiveness of using the potential of water management complex determines not only the level water resource availability of regional economic entities, but also determines the character of long-term interaction between government and business. Occurs the need to harmonize the interests of

participants in this market, which is associated with a whole set of problems as the overall regional and intrafirm, including the development of management economic potential mechanism of enterprises water management complex.

Thus, we can speak about "embedding" the purposes of water allocation regulation in the region, with the potential for development of water management complex territory in passing from one level to another acquires new synergistic properties which are subject to control exposure to the appropriate level. In other words, of management actions have an impact on the potential of certain enterprises at the lowest level, which are combined at the next level in the potential of HHC, possessing new qualities, operate by which is not always possible, effective or appropriate on the basis of the same mechanisms.[3]

The obvious complexity and scope achieve these objectives in water management system area involves the refinement of methodological basis and instrumentality decision support unit focused on the implementation of the new strategic policy-making. It is in this context like effective development of region water management system is required a combination, convergence and complementarity of existing approaches to the management of complex structured economic systems.

In particular, we are talking about the fact that the idea of balance states interests should be implemented as the macroregulator of HHC enterprises, regional HHC, the region as a macro and water consumers.

The list of references:

[1] URL: <http://www.mnr.gov.ru/regulatory/detail.php?ID=128717> (Water strategy of the Russian Federation for the period until 2020. Approved by the decree of the Government of the Russian Federation dated 27 August 2009 N 1235-r - Electronic text data - Access mode: <http://www.mnr.gov.ru/regulatory/detail.php?ID=128717> (accessed 07.07.2016).

[2] Russia: Danilov-Danilyan V.I., Khranovich I.L. Water resources management. Harmonizing water use strategies (rus). M.: NAUCHNYI MIR, 2010. 232p. (rus).

[3] The Federal target program "Development of water management complex of the Russian Federation in 2012 - 2020 years". Approved by the Decree of the Government of the Russian Federation of 28 July 2011 g. № 1316-r. - Electronic text data - Access mode: <http://fcp.economy.gov.ru/cgi-bin/cis/fcp.cgi/Fcp/ViewFcp/View/2016/403?yover=2018> (accessed 07.07.2016).

Contacts:

E. Mikhalkina
Doctor of Economics, Professor Faculty of Economics. Southern Federal University
E-Mail: evmihalkina@sfedu.ru

16. NEW IDEAS FOR FENESTRATION

Dr. Alexander Spiridonov(1), Ing. Tagir Akhmyarov(2), Dr. Prof. Igor Shubin(3)

(1,2,3)NIISF RAABC;

ABSTRACT

The authors propose new design principles for fenestration – windows, façade and other translucent elements of buildings, based on which it is possible to obtain energy efficiency and recover heat previously lost to the atmosphere, whilst aerating rooms through windows and façade without entailing energy losses.

Keywords: *energy effective construction, ventilated constructions, window, façade, energy saving active system, heat recovery*

Windows and facade are the weakest element of the envelopes of a building in terms of heat insulation characteristics. Therefore, required minimum values for the reduced heat transmission resistance of walls, windows and balcony doors regulated by Moscow standards of 1995 (R-value) [1], differ 2.94 times (1.0 and 0.34 m² •°C/W), and according to the most recent Russian national standard document of 2012 [2] they differ 5.80 times (3.13 and 0.54 m²•°C/W).

However, according to the Moscow standard documents [3] which are intended for the design of new buildings since 2016, this ratio slightly decreases: to 3.8 times (3.80 and 1.00 m² • °C/W).

From the point of view of thermal physics, to save energy during the building's operation, it would be better not to use fenestration structures at all. The use of day lighting, however, is still necessary according to wellbeing standards both in residential and commercial, as well as in most industrial buildings [4]. The inefficiency of constructing windowless buildings has already been proved in the 1940s and 1960s [5–8].

It is clear that the main real heat losses from rooms occur through fenestration: between 30% and 60% of general heat is lost, depending on the structure of windows and facades, the environmental conditions, evaluation methods and on some other factors.

In recent years, windows and facades have developed significantly: both in terms of increases functionality and operational indicators, and by using advanced modern technologies. In Figs. 1 and 2, the improvement of light-transmission in filling and of wooden windows is shown using the reduced heat transmission resistance indicator.

So far, the biggest Russian companies producing windows and facade, are able to manufacture it with R-value of 0.8–1.0 m² •°C/W [9] on a massive scale without considerable problems. However, to achieve values for this indicator which can be characterised as having heat-insulating efficiency greater than 1.2 m²•°C/W, it is necessary to apply new and expensive technological solutions.

This being said, there have been fenestration developed in recent years [10,

11], the R-value of which reaches $1.5\text{--}2.0 \text{ m}^2 \cdot \text{°C/W}$.

For improved functional indicators of traditional fenestration and its glazing, various modern technological solutions are used, including the following:

- **electrochromic glass.** This technology was developing over a long period of time, however today it is already being mass produced, and has shown its efficiency when glazing window and facade, especially in regions with hot climates, as well as on southern and western facades of buildings. The essence of this technology is its ability to change the optical transmission of the glass because of a special coating influenced by electric current, which makes it possible to provide a comfortable microclimate in the premises;
- **new generation heat-reflecting and multipurpose glass.** Such glass is manufactured using both traditional magnetron sputtering of a special coatings on the glass, and with the application of “pouring” and other technologies, which allow improving heat engineering and lighting characteristics of multiple glazed unit windows, so that they work effectively in both winter and summer operation conditions;
- **glass with a photoelectric effect.** Over the last several years, it has been possible to develop special effective light transparent glass coatings, which can transform sunlight into electric energy, making facades part of the building envelopes and to providing additional energy efficiency to fenestration and facade elements;
- **vacuum multiple glazed units (VIGU).** Such multiple glazed units appeared on the market for the first time in the early 1990s, however, they had some serious limitations to their use in most buildings. In recent years, a considerable progress has been made in bringing these elements to industrial production. Therefore, a sharp increase in the production of VIGU can be expected in many countries: in the EU, USA, China, Japan and probably in Russia, which will allow for a substantial improvement in the R-value of the traditional fenestration (Fig. 1);
- **glazed units (IGU) with electrical heating.** During the last decade, the use of fenestration on roofs, ceilings of atriums, glass canopies, etc. has become widespread. However, in weather conditions typical to Russia, they require frequent snow removal. For these such structures, as well as for the removal of condensate from swimming pool enclosures, IGU and glass with electric heating have become very popular. As a rule, these are made using glass with a solid heat-reflecting coating. As it is possible to deliver electric current to the heat-reflecting coating, a wide range of temperature adjustment of the glass is possible. The application of such IGU in the northern climate regions of Russia is effective in increasing the comfort of occupants in residential rooms and offices;
- **filling the gap between panes of glass with aerogel.** The first attempts to fill the IGU gap were made in the late 1970s. The unique thermal characteristics of this material, discovered by an American chemist Stephen Kistler in 1931, make this possible. However, despite the very low heat conduction of aerogels and their high strength, a variety of technological problems appear during their practical use in IGU. These are caused by filling cavities between the glass panes, and by a high hygroscopicity of the aerogels. Besides, these materials are translucent and expensive, which also prevents

their wide application. According to some sources, considerable progress in use of aerogels in the window industry has been made in recent years;

- **composite materials of frame structures.** To increase strength, remove steel enforcers in standard PVC profiles, as well as to increase the heat engineering characteristics of windows as a whole, an entire generation of window profiles of various composite materials has been developed, which includes fibreglass, combinations of PVC and glass-reinforced plastic, a mixture of sawdust and PVC grains and many other things. Most of these have been little used up till now. At the same time, due to the increase of thermal and ecological requirements for windows in most developed countries, and with the need to recycle PVC and of other types of production waste, many large companies in recent years have paid closer attention to these materials. This provides hope for their increased application in the coming years.

It should be noted that the improvement in the thermal characteristics of fenestration occurs mainly as a result of “passive” actions (increasing number of chambers in the IGU, amount of glass with low-E coating, the use of more effective inert gases in gap, increase in the thickness of frames, etc.). However, as with models for opaque envelopes [12], such an approach to the increase of R-value of fenestration is in most cases inefficient from the economic point of view. Increasing the number of glass layers naturally reduces the visible transmittance of the structure.

The transition to the modern tight windows with IGU in multi-storeyed buildings had positive impacts, such as operational convenience, decrease in heat losses and improvement of acoustic characteristics, but led to a deterioration of the room air mode. Almost all window and facade structures of “the European type” do not provide standard air exchange in the rooms. This leads to uncomfortable microclimate conditions and the growth of fungus and mould on the inner slopes and walls. “Salvo airing” of rooms proposed by many window manufacturer companies is uncomfortable and reverses all efforts to increase heat efficiency of fenestration, completely negating the principles of energy saving policies. To improve the ventilation of rooms, (especially in multi-storeyed buildings with natural ventilation, which practically never works) ventilation valves became popular [13]. However, these also increase the cost of the windows.

Based on the new design principles for enclosing structures, proposed by the authors in [14], it became possible to develop energy efficient ventilated fenestration (EEVF). It was possible to improve R-value and recover a considerable part of the thermal flow, which had previously been lost to the atmosphere. The ventilation of rooms by external air via windows and facades was improved with very little additional energy losses. A mechanism for the proposed operating principle for modern energy efficient and ventilated fenestration (EEVF) is described previously in more details in [12, 14, 15].

It should also be noted that a combined effect of the heat-reflecting screen in a gap and ventilation via this gap with an active recovery of heat and moisture into a room using external cold air, raises the thermal effect multiple times. This has been proved experimentally during numerous experiments [15, 16].

The nature of these processes depends on the geometry of the layer, thermal characteristics of the materials, on the temperature of inner and external air, consumption of the filtered air, on structure of the input and output valves. For each specific module of energy efficient ventilated fenestration (EEVF), these parameters can be optimised and adjusted by locating heat-reflecting screens and consumption of input air through recirculation of the ventilation discharge. All these processes will be described in more detail in the next article of the series, in which the results of the multiple research efforts into this new concept of energy efficient ventilated envelopes (EEVE) carried out in the Research Institute for Building Physics in 2013–2015 will be provided.

Several versions of such fenestration (Figs. 3–6) were developed based on the new principles proposed by the authors. After passing through a layer of air, the heated external air enters the recovery mechanism.

Fig. 3 shows the structure of EEVF, which requires barely any change to the window profile. PVC profile frames are combined (one frame is made with a single piece of glass, the other is manufactured with IGU). Between these frames, the main principles of twist-and-steer ventilation with active thermal flow recovery are implemented. This is a relatively simple the method for the modernization of windows and facade, however the initial costs are significant. Nevertheless, this method has a short payback period due to the sharp improvement of the R-value of the windows.

To make popular wood-aluminum window units (Fig. 4) according to the principles proposed by the authors new external aluminum frames are necessary. In the space between the external glass and inner IGU, there is a removable heat-reflecting screen (blind) and distributing devices for external air inlets and the collection of the heated air flow, which are necessary for the effective ventilation of the space between panes of glass and for the active recovery of the thermal flow.

Similarly to the modernization of wood-aluminum windows (Fig. 4), thermal recovery improvements according to the design principles of EEVF, proposed by the authors, is also possible in warm aluminum windows (Fig. 5).

In modern aluminum rack-girder facade systems, IGU of a 75 mm thickness and more can be installed. This allows for the modernization of most modern facades according to the concept of energy efficient ventilated fenestration developed by the authors. Implementation of the concept of energy efficient ventilated facade in this case is possible both with standard IGU, and with slightly modified aluminum profiles (Fig. 6). Applying these principles is especially interesting in the unitized facades, which are widely used, because it is possible to reduce the problems for refurbishment as systems of air distribution and collection are used simultaneously across several floors.

It is difficult to refurbish residential and commercial buildings which date from the period of rapid construction from the 1950s to the early 2000s, which have huge heat losses through envelopes. The sanitation is achieved through additional heat insulation of the facades and replacement of some engineering systems. Monitoring the costs for heating and ventilation between 2011 and 2013 for over 150 buildings in Moscow demonstrates both energy and economic inefficiency. In recent years, a popular refurbishment method for old inefficient buildings, has

involved the construction of an additional facade (Fig. 7). This has been dubbed the “double skin façade”. This method allows not only securing energy savings but also improved convenience of the façade. Certainly, this method is much more expensive than those usually applied in Russia. But the results of the additional heat insulation of facades obtained in Russia, are also disappointing.

The energy efficient ventilated fenestration proposed by the authors are ideally suited for double skin façades and for the refurbishment of old buildings (Fig. 8). Applying our methods, it is possible to provide not only additional heat insulation and reduce R-value, but also to provide a comfortable microclimate in premises.

Besides, preliminary estimates show that when using EEVF, additional external thermal insulation can be minimized, leading to a reduced payback period for refurbishment costs.

It should be noted that envelopes and fenestration with the active recovery of thermal flow and moisture based on the principles stated in this article, as well as in previous publications [12, 14], can provide not only considerably reduced resistance to heat transmission and less heat loss [15] but also work effectively in both winter (recovery of thermal output flows), and summer (reduced air-conditioning costs). Besides, when improving the thermal characteristics of fenestration through active energy saving, it becomes possible to increase the surface area of glass facades, improving the amount of day lighting. It avoids the negative impacts of additional glass cover layers and heat-reflecting screens on day lighting. It should be also noted that heat-reflecting screens can only be used at night time.

In conclusion, energy efficient ventilated fenestration (EEVF) proposed by the authors, can be implemented across almost all types of window systems and profiles. However, the implementation of our proposals is not so simple, as can be seen in the schemes provided above (Figs. 3–6, 8). For each structure type, it is necessary to calculate EEVF modules, arrange ventilation systems for air layers, and create a system of replaceable/adjustable heat-reflecting screens. Nevertheless, the outcome in energy savings will make up for these costs.

The authors invite architects, contractors, investors, companies manufacturing window system profiles, windows and hinged facade systems to cooperate in the implementation of these proposals.

REFERENCES

- [1] Building standards and rules. Building regulations СНиП II-3–79* “Building heat engineering» (1995).
- [2] Rules and regulations СП 50.13330.2012. “Thermal protection of buildings» (revised edition of Building regulations СНиП 23–02–2003).
- [3] State program of Moscow city “Town building policy for 2012–2016”.
- [4] Rules and regulations СП 50.13330.2011. “Artificial and natural illumination” (revised edition of Building regulations СНиП 23–05–95*).
- [5] N.M.Gusev. Foundations of building physics // *Stroyizdat*, Moscow, 1975.440 p.
- [6] V.K. Litskevich. Dwelling and climate // *Stroyizdat*. Moscow. 1984. 288 p.

- [7] A.K.Solovyov. Physics of medium // *Publishing house ACB*. Moscow, 2011. 342 p.
- [8] A.V.Spiridonov, I.L.Shubin. Development of fenestration in Russia // *Svetotekhnika*. № 3, 2014, pp.46–51.
- [9] A.V.Spiridonov. Whether installing energy saving windows is profitable? // *Energoberezhenie* (Energy saving), № 3, 2013, Moscow, pp. 62–67.
- [10] Carmody J., Selkowitz S., Arasteh D., Heschong L. Residential Windows – A Guide to New Technologies and Energy Performance, New York, *W.W.Norton* 2007, 256 p.
- [11] John Carmody, Stephen Selkowitz, Eleanor Lee, Dariush Arasteh, Todd Willmert «Window Systems High-Performance Buildings», *W.W.Norton&Company*, 2003, 400 p.
- [12] T.A.Akhmyarov, A.V.Spiridonov, I.L.Shubin. Creation of external envelopes with a raised level of heat protection // *Energoberezhenie* (Energy saving), № 6, 2014, Moscow, pp.26–33.
- [13] STANDARD OF THE NATIONAL ASSOCIATION OF BUILDERS 2.23.61–2012 WINDOWS. Part 1. “Technical requirements to structures and design”, Moscow, Bulletin of building engineering, 2013, 28 p.
- [14] T.A.Akhmyarov, A.V.Spiridonov, I.L.Shubin. Principles of design and evaluation of external envelopes using modern technologies of “active” energy saving and of recovering thermal flow // *Zhilishtshnoe stroitel'stvo* (Housing construction). № 6, 2014, Moscow, pp. 8–13.
- [15] T.A.Akhmyarov, V.S.Belyaev, A.V.Spiridonov, I.L.Shubin. A system of active energy saving with heat recuperation // *Energoberezhenie* (Energy saving), № 4, 2013, Moscow, pp. 36–46.
- [16] V.S.Belyaev, V.A.Lobanov, T.A.Akhmyarov. Decentralized input-extract, input-outlet ventilation systems with heat recuperation // *Zhilishtshnoe stroitel'stvo* (Housing construction). № 3, 2011, Moscow, pp. 73–77.

Contacts:

E-Mail:

(1) spiridonov@aprok.org, ^(,2,3) niisf@niisf.ru

17. THE INFLUENCE OF JUNCTION CONSTRUCTION OF BALCONY AND EXTERNAL WALL ON DISTRIBUTION OF HEAT EXCHANGE COEFFICIENT ON THE SURFACE OF MONOLITIC CONCRETE BALCONY SLABS

Umnyakova Nina P1., Andreitseva Kristina S.2, Smirnov Vladimir.A

(1,2,3) NIISF RAABC

Most of the built and maintained buildings have balconies on the facades, what impart more favorable and architectural aspect to the structures and make residents feel comfortable during the springs and summers. However, the research on balconies impact on heat protection properties of the walls almost have never been undertaken [1-4]. It could be explained by the fact that experiments studying this problem are insufficient.

The complex thermal physics research on estimation of heat protection properties of the wall and balcony connection has been held in the Scientific Research Institute of Building Physics. It allowed to determine heat insulation effectiveness while the temperature of outer air had been changing [5,6]. There were the field observations and the experiment in the climate chambers.

The parts of the outer wall with two different wall, floor and the balcony constructive connections with different types of heat insulations were erected. The experimental construction included the monolithic reinforced concrete wall 200 mm width and $\gamma = 2400 \text{ kg/m}^3$ dense. Outside the wall was warmed by polystyrene foam 120 mm width. The surface of polystyrene foam was plastered on polymer mesh with using of polymer plaster mix. One part of the construction was a traditional wall and floor connection with using of perforations inside the floor 500×120 mm filled with polystyrene foam $\gamma = 15 \text{ kg/m}^3$ dense. These perforations were made in one section with the heat insulation layer.

Inside the other part of the construction there was the carrying heat-insulated element Schoeck Isokorb. It is a rectangular element 120 mm width made by polystyrene foam "Neopor" with incorrigible steel reinforcement. The monolithic floor and balcony were joined by means of this metal armature.

During the experimental specimen mounting the temperature and heat flow sensors were set on the surfaces and inside the balcony slab, monolithic floor and walls both in inner and outer sides.

The research inside the climate chambers was undertaken while the temperature had the following indexes $t_{\text{int}} = 20 \text{ }^\circ\text{C}$, $t_{\text{ext}} = -10 \text{ }^\circ\text{C}$, $t_{\text{int}} = 20 \text{ }^\circ\text{C}$, $t_{\text{ext}} = -20 \text{ }^\circ\text{C}$, $t_{\text{int}} = 20 \text{ }^\circ\text{C}$, $t_{\text{ext}} = -0 \text{ }^\circ\text{C}$ и $t_{\text{int}} = 20 \text{ }^\circ\text{C}$, $t_{\text{ext}} = -40 \text{ }^\circ\text{C}$.

Analysis of temperature sensors indexes shew that because of perforations and carrying heat-insulating element Schoeck temperature in the balcony slab and outer wall connection area increased greatly in comparison with the heat-conducting inclusion structural assembly.

The new technical dependence was approached. It allows to have an outer envelope of building with high heat shield properties w t spite of balconies presence. This dependence appears with the different outer air temperature indexes.

The maximum heat loss are in the place of the balcony slab and outer wall connection and the minimum ones are in the face of the balcony slab. For example, heat loss value for the heat-conducting inclusion structural assembly is about $46 - 148 \text{ W/m}^2$, in the face of the balcony slab this value is $5.8 - 7.7 \text{ W/m}^2$, for the construction with Shoeck – $4.6 - 16 \text{ W/m}^2$, in the face of the balcony slab – $2.5 - 2.9 \text{ W/m}^2$.

Because of received experimental data heat loss values distribution on the balcony slab in dependence of the joint construction and air environment allowed to determine the heat exchange coefficient for the balcony slab. Changing of these coefficients in different constructions is shown on the pics.

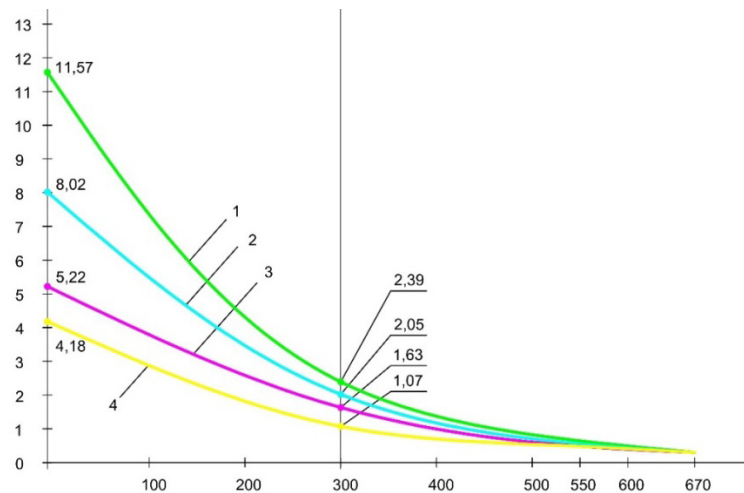

Fig. 1. The average heat-exchange coefficient changing depends on the balcony slab length on the surface of concrete slab in the traditional construction with using of perforations, $t_{ext} = -40 \text{ °C}$ (1), $t_{ext} = -30 \text{ °C}$ (2), $t_{ext} = -20 \text{ °C}$ (3), $t_{ext} = -10 \text{ °C}$ (4).

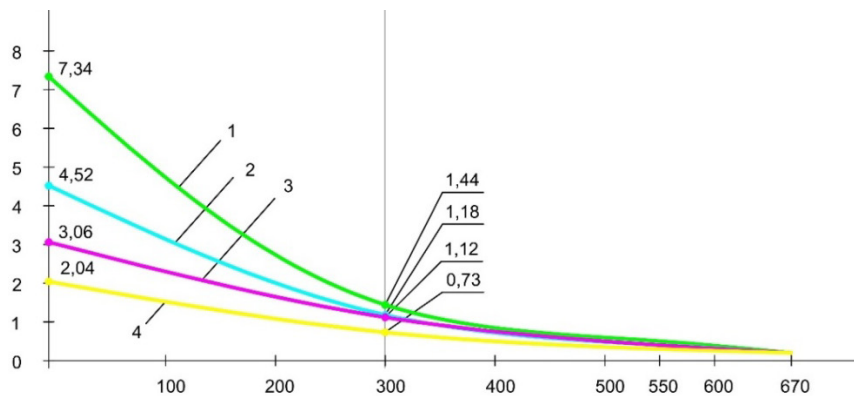

Fig. 2. The average heat-exchange coefficient changing depends on the balcony slab length on the surface of concrete slab in the construction with using of element Shoeck, $t_{ext} = -40 \text{ °C}$ (1), $t_{ext} = -30 \text{ °C}$ (2), $t_{ext} = -20 \text{ °C}$ (3), $t_{ext} = -10 \text{ °C}$ (4).

Consequently, the research allowed to introduce the numerical values of the heat exchange coefficients and its distribution along the balcony slab. The analysis of the received data showed the value of the heat exchange coefficient on the balcony slab surface is considerably influenced by the construction of the examined unit. The most intense heat exchange on the balcony slab surface is observed in the area of balcony and outer wall joint, and the least intense heat exchange is on the 30 sm distance from the wall.

The minimum values of the heat-exchange coefficient values are received because of mounting the carrying heat-insulating element Shoeck, so the least heat loss and the least intense heat exchange between the balcony slab surface and outer air appears in this case. And opposite, the maximum values of the heat-exchange coefficient value and the most intense heat exchange between the balcony slab surface and outer air are received in the case of reinforced concrete heat conductive inclusive between perforation.

References

- [1] Umnyakova N.P., Egorova T.S., Andreitseva K.S., Smirnov V.A., Lobanov V.A. New constructive solution of interface of external walls to monolithic interflooroverlappings and balcony plates.// Stroitel'nyematerialy. 2013. No. 6, pp. 28 – 31. (In Russian).
- [2] Fokin K.F. Stroitel'naya teplotekhnika ograzhdayushchikh chastei zdanii [Construction the heating engineer of the protecting parts of buildings]. Pod red. Yu.A. Tabunshchikova, V.G. Gagarina. 5 – eizd., peresmotr. Moscow: AVOK-PRESS. 2006. 256 p.
- [3] Malyavina E.G. Teplofizikazdanii [Thermophysicsof buildings]. Uchebnoeposobie. Moscow: ASV. 2013.144 p.
- [4] TabunshchikovYu.A., Brodach M.M. Sistemnyi analiz proektirov aniyaenergoeffektivnykh zdaniy. Architecture and Modern Information Technologies. 2015. № Special. P. 14. (In Russian).
- [5] Umnyakova N.P., Andreitseva K.S., Smirnov V.A. Effective solution of a cover of the building and biospheric compatibility. Biospheric compatibility: person, region, technologies. 2013. No 4, pp. 51-64. (In Russian).
- [6] Umnyakova N.P., Andreitseva K.S., Smirnov V.A. Engineering method of calculation of temperature in knot of interface of an external wall with monolithic interfloor and balcony plates when using of the bearing heat-insulating element of Shekkizokorb. // Stroitel'stvo I rekonstruktsiya. 2013. No. 6 (50), pp.53 – 64. (In Russian).

Contacts:

E-Mail: ^(1,2,3)niisf@niisf.ru

18. STROMERZEUGUNG DURCH ERDGAS- ENTSPANNUNG AM BEISPIEL EINES GRÖßEREN ERDGAS- VERBRAUCHERS

Dipl.-Ing- Robert Bergmann

Energieeffizienzberatung und -management

1. Einleitung

Die Nutzung der Entspannung von Gasströmen, insbesondere Erdgas-strömen, erscheint als ein noch kaum erschlossenes Potenzial zur Gewinnung mechanischer bzw. elektrischer Energie in der RF. Vorliegende Arbeit soll dazu allgemeine Grundlagen liefern und die Machbarkeit anhand einer konkreten Situation in der RF nachweisen.

2. Schlussfolgerungen

Die Konzipierung einer Turboexpanderanlage für einen sehr großen Erdgas-strom, welcher ein Großkraftwerk versorgt, ist zwar eine technisch sehr interessante Aufgabe, verspricht aber unter den gegebenen Randbedingungen keinen wirtschaftlichen Betrieb. Für einen s.g. Unabhängigen Stromerzeuger (IPP) oder einen industriellen Stromverbraucher wäre eine andere wirtschaftliche Darstellung möglich gewesen.

3. Voruntersuchung/ Recherche

In Deutschland wird z.T. seit vielen Jahrzehnten eine überschaubare Anzahl von örtlichen Gasentspannungsanlagen zur Stromerzeugung betrieben. Aus einer vom Autor durchgeführten Voruntersuchung zu diesen Anlagen konnten etwa 30 Turbo- bzw. Kolben- Entspannungsanlagen deutschlandweit erfasst und klassifiziert werden. In der Annahme, in der Kürze der verfügbaren Zeit nicht alle Anlagen ermittelt zu haben, geht der Autor vom Vorhandensein von etwa 40-50 Anlagen in Deutschland aus. Hauptsächlich handelt es sich um Turboexpander, seltener um Kolbenmaschinen, meist im Leistungsbereich einiger 100 kWe und ausnahmslos im Besitz privater Industrieunternehmen oder kommunaler Versorgungsbetriebe, die ein möglichst großes relatives Druckgefälle des Erdgases nutzen können.

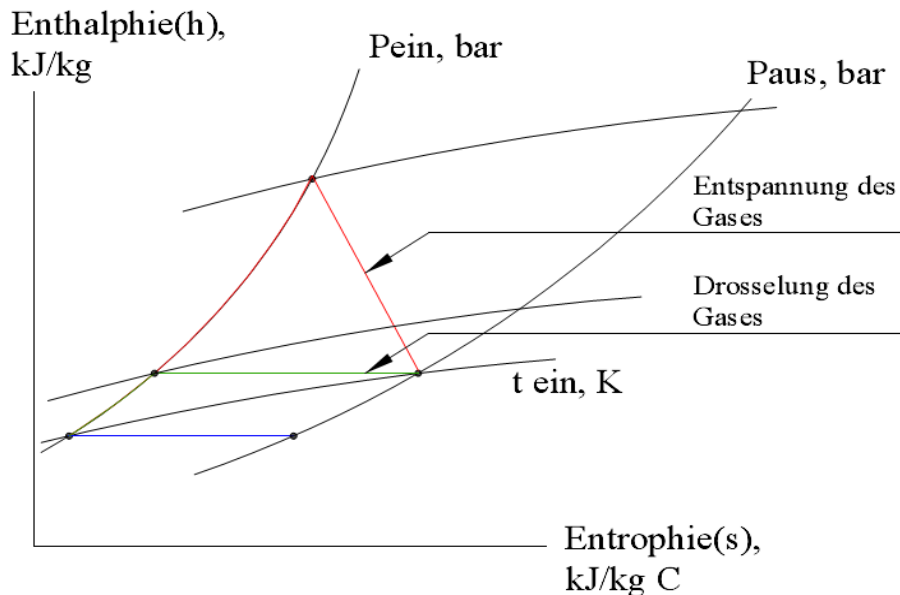
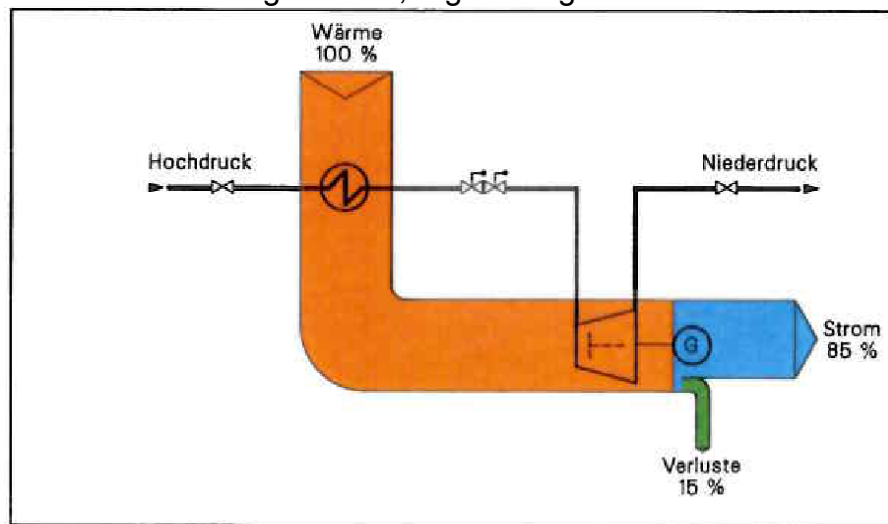

Fig. [1] Schema der Möglichkeiten der Gasentspannung ohne (isenthalp) und mit (annähernd isentrop) Gewinnung mechanischer Energie

Häufig werden diese Anlagen in Kombination mit standardisierten BHKW betrieben, welche die kostengünstige Wärme zur Vor- oder Nachwärmung des Erdgases liefern, dessen Entspannungspotenzial letztlich zur Stromerzeugung genutzt wird. Hier erhält der Betreiber der Anlage den gesetzlichen Bonus für Strom aus KWK. In wenigen Fällen kommt Wärme aus erneuerbaren Energiequellen, wie z.B. aus Grubengas zum Einsatz, das laut KWK-Gesetz zu diesen Quellen zählt.

Der exergetische Nutzungsgrad der Anlagen liegt, bezogen auf die vor Ort eingesetzte Wärme nachgewiesen, regelmäßig im Bereich von 80 bis 90 %.



Energiebilanz einer Gas-Entspannungsanlage
Fig. [2]

Der Markt für Turbo- oder Kolbenexpander- Anlagen ist sehr überschaubar, die Investitionen vergleichsweise hoch, die Lebensdauer der Anlagen meist überdurchschnittlich lang. Allerdings haben notwendig gewordene Generalreparaturen auch mehrfach zur endgültigen Stilllegung von Anlagen geführt.

In einem Fall hat der Autor in einem größeren Chemiebetrieb eine Anlage zur Entspannung hochtoxischen und aggressiven Gases recherchiert, welche bereits mehr als 30 Jahre praktisch unterbrechungsfrei betrieben wird. Insgesamt beträgt der Anteil der Gasentspannungsanlagen zur Stromerzeugung in Deutschland mit zusammen ca. 60 GWh/Jahreserzeugung etwa 0,01 % und ist damit nur von lokaler Bedeutung.

4. Expertise zu Vorprojekten für eine Turboexpanderanlage in der RF

Dem Autor wurde zunächst angetragen, eine Vielzahl von bereits zuvor ausgearbeiteten Varianten der Nutzung eines sehr großen Erdgasstromes zur Stromerzeugung mittels Turboexpandern zu bewerten. Diese Varianten spiegelten ein breites Spektrum technischer Möglichkeiten zur Bereitstellung der erforderlichen Wärme zur Vor- bzw. Nachwärmung des Erdgasstromes wider, von einem einfachen Heizkessel über BHKW bis zu kleinen GuD-Anlagen. Alle Vorprojekte gingen vom vertraglich vorgegebenen Druckgefälle des Erdgases in der Höhe des Gaslieferanten aus.

Die energetische, energiewirtschaftliche und ökologische Synopse führte letztlich zu dem Ergebnis, dass die Stromgestehungskosten aller dieser Varianten nicht wettbewerbsfähig und die spezifischen CO₂-Emissionen zu hoch waren, um mit dem Großkraftwerk konkurrieren zu können, das den Erdgasstrom durch Verbrennung zur Stromerzeugung nutzt. Hinzu kamen ungeklärte Fragen der elektrischen Leistungsabführung der Turboexpanderanlage und ihres Standortes in einem Waldgebiet mit Brandgefahr.

Daraus erwuchs für den Autor die Aufgabe des Entwurfes einer effizienteren Turboexpander-Variante.

5. Variante „X“

Besagtes Großkraftwerk verfügt bereits über Dampfenntnahmen (Anzapfungen) an den Turbinen, die hauptsächlich, über Dampf/Heizwasser-Wärmeübertrager, zur Fernwärmeversorgung einer nahe gelegenen Kleinstadt und zur Deckung des Wärmeeigenbedarfes des Kraftwerkes bestimmt sind. Es sind ausreichende Kapazitätsreserven vorhanden.

Das Erdgas wird dem Kraftwerksbetreiber vom Gasversorger aus einer Ferngas-Magistrale über eine Gasreduzierstation vertragsgemäß mit einem Druck zur Verfügung gestellt, der technisch keine Bedeutung hat. Der Kraftwerksbetreiber unterhält deshalb eine weitere eigene Druckreduzierstation mit Gasnachwärmung, um damit den erforderlichen Betriebsdruck für die Gasbrenner der Kraftwerkskessel bereit zu stellen. Insgesamt steht aber ein Druckgefälle für das Erdgas von mindestens 60:1 zur Verfügung.

Der Autor hat daraufhin eine mehrstufige Turboexpanderanlage konzipiert, in der das Erdgas stufenweise mit Dampf aus dem Großkraftwerk vorgewärmt wird. Dabei waren die Druckstufen der Expander und die Vorwärmung thermodynamisch zu optimieren, die Wärmeübertrager und Turboexpander zu dimensionieren und dabei eine geplante Ausbaustufe des Großkraftwerkes zu berücksichtigen. Angeschlossen haben sich Wirtschaftlichkeitsberechnung und ökologische Bewertung dieser Variante, die ohne Verbrennungsvorgänge vor Ort auskommt, außerdem eine schematische Zuordnung der Baugruppen auf die infrage kommenden Standorte, ohne notwendige Neuerschließungen.

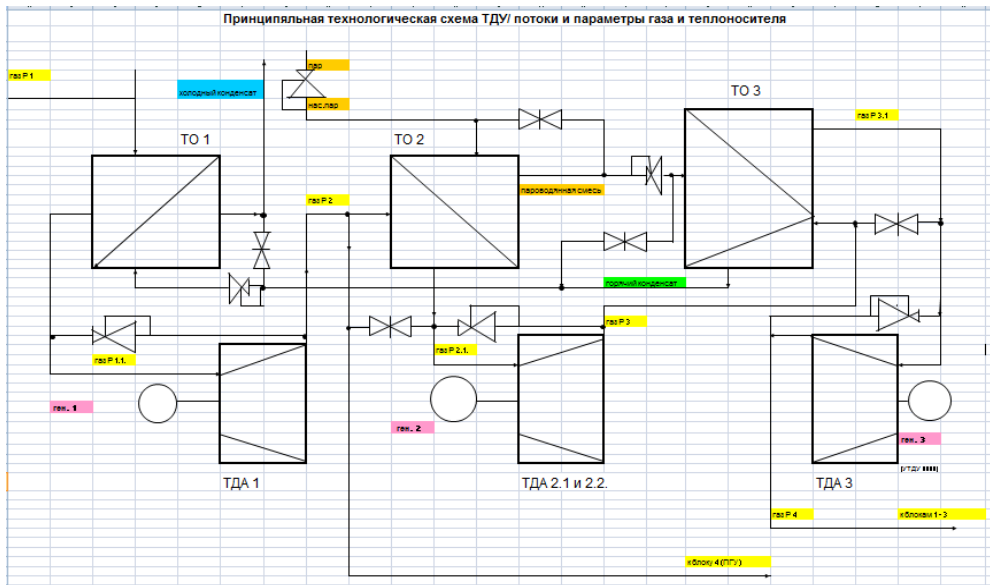

Fig. [3] Schema des Aufbaus und der Funktion der Turboexpanderanlage
 Схема размещения ТДУ

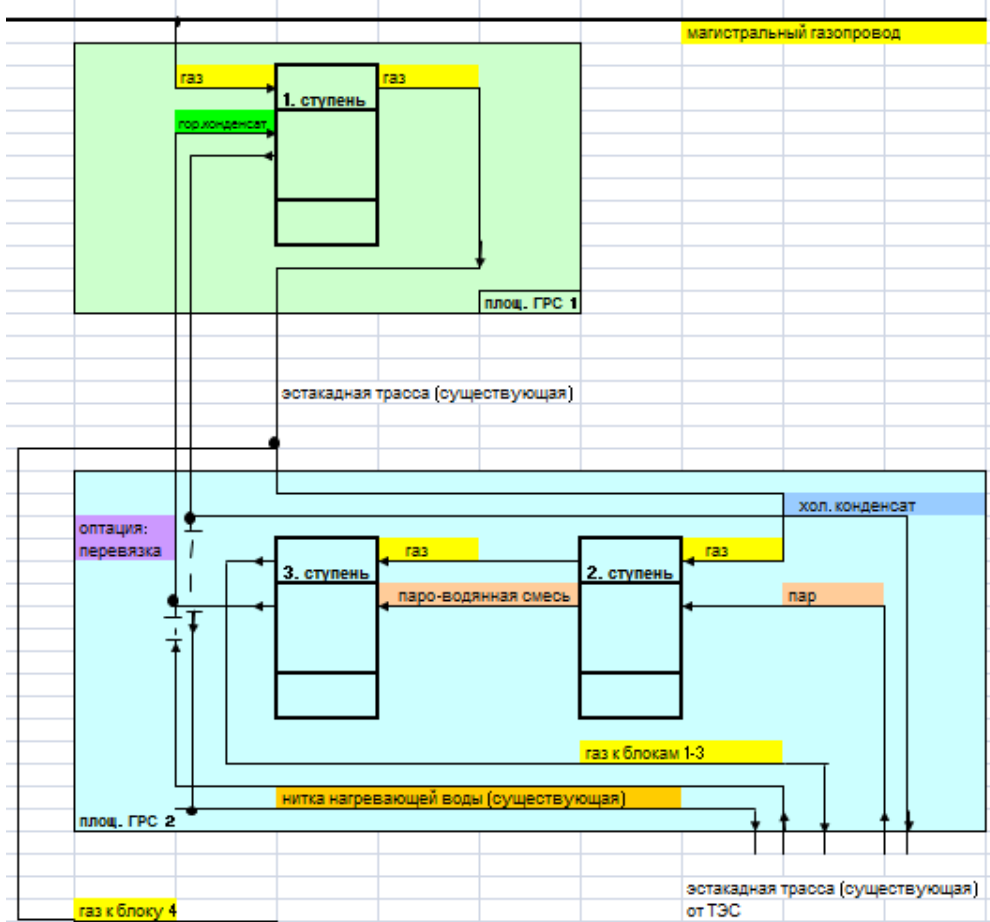

Fig. [4] Schematische Anordnung der Baueinheiten auf den Baufeldern

Im Ergebnis konnte zwar gezeigt werden, dass diese „Variante X“ in allen ökonomischen, ökologischen und technischen Parametern die beste im Vergleich mit den Vorprojekten ist, aber dennoch nicht wettbewerbsfähig zur Stromerzeugung im Großkraftwerk. Ihre projektierte elektrische Gesamtleistung erreichte rd. 1 % der Leistung des Großkraftwerkes.

Allerdings spielte dabei auch eine positive Rolle, dass die Nutzung der Anzapf-Wärme aus dem Großkraftwerk dessen ökonomische und ökologische Parameter selbst auch verbessert hat, was der „Variante X“ zuzurechnen war. Ungünstig wirkte sich der sehr niedrige Preis für erzeugten Strom aus.

So erübrigte sich dann im Weiteren auch die Klärung der elektrischen Leistungsabführung und weiterer Randfragen zu dieser Anlage.

[1] *me-lrt.de/thermodynamik*

[2] *ASUE e.V.*

[3] *Autor*

[4] *Autor*

Kontakte:

Dipl.- Ing. Robert Bergmann
Energieeffizienzberatung und –management
+49(0)3643 773105
E-Mail: eebm_bergmann@gmx.eu

19. ВЫРАБОТКА ЭЛЕКТРОЭНЕРГИИ ТУРБОДЕТАНДЕРНОЙ УСТАНОВКОЙ В КРУПНОМ ПОТОКЕ ПРИРОДНОГО ГАЗА

инж. Роберт Бергманн

консультант по энергосбережению и менеджменту

Использование потенциала компримированных потоков газа для выработки механической либо электрической энергии является малой долей среди возможностей выработки энергии, хотя уже давно подтверждено на практике.

Причины этого – разные. В основном они состоят в дорогостоящем капиталовложении и в отсутствии источников дешёвого тепла для подогрева газа.

Потенциал расширяющегося газа кроется не в его давлении, как часто предполагают, а в находящейся в нём либо подводимой в него энтальпии. Тем не менее, большой перепад давления газа является важным, но не достаточным условием.

После того, как была установлена степень распространения этой технологии в Германии, необходимо было разработать конкретный проект выработки электроэнергии путём использования потенциала очень большого потока природного газа, снабжающего крупную ТЭС в РФ.

Результаты проекта показали, что благодаря использованию тепла из уже существующих отборов турбин ГЭС и путём оптимизации ступеней расширения природного газа, возможно удовлетворительное решение задачи с точки зрения экономики и экологии, но не выгодное с точки зрения выработки электроэнергии на существующей крупной ТЭС. Особо низкая стоимость за отпущенную электроэнергию также играла свою отрицательную роль в экономическом вопросе.

Тем не менее, в Германии работает некоторое количество таких установок мощностью порядка несколько сотен киловатт каждая, на выгоду владельцев, что с одной стороны связано с законными надбавками к стоимости отпущенной электроэнергии, выработанной в когенерационном режиме, с другой стороны – с довольно длинными сроками службы оборудования при низких затратах на ремонт, а также часто обусловлено источниками дешёвого тепла, не редко сбросного тепла или тепла из возобновляемых источников, что приводит в свою очередь к надбавке оплаты за отпущенное электричество. Иногда вместо турбодетандеров применяются поршневые агрегаты.

В итоге работы можно назвать выработку электроэнергии турбодетандерной установкой интересным способом при особых условиях.

контакт:

Dipl.-Ing. Robert Bergmann
Energieeffizienzberatung und –management
++49(0)3643 773105/ ++49(0)171 6909693
E-Mail: eebm_bergmann@gmx.eu

20. IDENTIFICATION OF SEISMIC STABILITY OF HIGH-RISE BUILDINGS AND CONSTRUCTION OBJECTS BY CORRELATION MATRICES.

1Ulkar Sattarova

¹Azerbaijan University of Architecture and Construction, Baku, Azerbaijan

Abstract: It is shown that correlation matrices and normalized correlation matrices are applied in solving of static and dynamic identification problems for diagnostics and prediction of technical condition and seismic stability of high-rise buildings and building structures. Specific characteristics and properties of those matrices are determined. It is known that a high-rise building consists of a large number of structural elements, any of which can trigger a train of events resulting in destruction of the whole building. Specialists therefore must be capable of performing precise diagnostics, predicting deformation and vibration of a building or other building structure and forecasting and promptly determining degree of damage. Only maximally quick reliable threat identification and immediate alarming will allow carrying out of evacuation and preventing negative effects caused by gas leakage, fire situations, troubles with electrical equipment, including elevators, etc.

Keywords: correlation matrices; normalized correlation matrices; static and dynamic identification; diagnostics; prediction; seismic stability; high-rise buildings; buildings structures

Main text:

INTRODUCTION

Constant monitoring of all structural elements, meanwhile, is first of all impossible due to technical and economic reasons; on the other hand, it does not produce the desired effect. Thereby, methods of indirect measurements in hard-to-reach spots, modeling and analysis methods, methods of empirical dependences, methods of one-dimensional, two-dimensional and complex multidimensional models are applied to solving of this problem. It allows one to carry out diagnostics of the technical condition of a high-rise building or building structure, predict a failure, determine the moment, at which mechanical deformations exceed threshold values, and detect the beginning of a rescue mission.

On the other hand, most accurate picture of the current condition of a high-rise building or other building structure, such as its wear rate, presence of hidden faults, etc., is obtained after dynamic tests. A full-scale monitoring of technical condition of a high-rise building therefore requires information on its dynamic characteristics and changes. In reality, dynamic probing and early diagnostics of deformation condition of bearing structures are as a rule based on analysis of

change in transfer functions built for building sectors of different height. This method is applicable to high-rise building of different architecture, and transfer functions in such cases are built for different sections of the building and constructions.

Transfer function of a building section is understood as correlation of components of power spectra of registered signals in two spots of the building, specifically, at the point of dynamic effect set, for instance, as a broadband impulse from an inelastic impact, and at the point, where this effect is registered after having passed through the part of the building under consideration. Such transfer function characterizes mode of deformation of constructions exactly in the part of the building, which the broadband impulse passed through.

Change in transfer function, in particular, change in values of force coefficients for different frequencies, indicates a change in the mode of deformation in this part of the building, which allows localizing such a change within the number of floors of the building between neighboring measure points.

This, diagnostics and prediction of technical condition and seismic stability of a high-rise building or a building structure require solving of static and dynamic identification problems. The paper considers specifics of the mathematical apparatus applied to solving of those problems.

PROBLEM STATEMENT

Solving of static identification problems by probabilistic-statistical methods is known to be reduced to numerical solving of correlation matrix equations.

$$\bar{R}_{\overset{\circ}{X}\overset{\circ}{X}}(0) \cdot \bar{C} = \bar{R}_{\overset{\circ}{X}\overset{\circ}{Y}}(0)$$

where

$$\bar{R}_{\overset{\circ}{X}\overset{\circ}{X}}(0) = \left\| R_{\overset{\circ}{X}_i \overset{\circ}{X}_j}(0) \right\| \square \begin{bmatrix} R_{\overset{\circ}{X}_1 \overset{\circ}{X}_1}(0) & R_{\overset{\circ}{X}_1 \overset{\circ}{X}_2}(0) & \dots & R_{\overset{\circ}{X}_1 \overset{\circ}{X}_n}(0) \\ R_{\overset{\circ}{X}_2 \overset{\circ}{X}_1}(0) & R_{\overset{\circ}{X}_2 \overset{\circ}{X}_2}(0) & \dots & R_{\overset{\circ}{X}_2 \overset{\circ}{X}_n}(0) \\ \dots & \dots & \dots & \dots \\ R_{\overset{\circ}{X}_n \overset{\circ}{X}_1}(0) & R_{\overset{\circ}{X}_n \overset{\circ}{X}_2}(0) & \dots & R_{\overset{\circ}{X}_n \overset{\circ}{X}_n}(0) \end{bmatrix}, \quad i, j = \overline{1, n}$$

$$\bar{R}_{\overset{\circ}{X}\overset{\circ}{Y}}(0) = \left\| R_{\overset{\circ}{X}_i \overset{\circ}{Y}}(0) \right\| \square \left[R_{\overset{\circ}{X}_1 \overset{\circ}{Y}}(0) \quad R_{\overset{\circ}{X}_2 \overset{\circ}{Y}}(0) \quad \dots \quad R_{\overset{\circ}{X}_n \overset{\circ}{Y}}(0) \right]^T$$

$$\bar{C} \square [c_1 \quad c_2 \quad \dots \quad c_n]^T$$

where \bar{c} is column vector of coefficients; $\left\| R_{\overset{\circ}{X}_i \overset{\circ}{X}_j}(0) \right\|$ is matrix of estimates of auto- and cross-correlation functions $R_{\overset{\circ}{X}_i \overset{\circ}{X}_i}(0)$, $R_{\overset{\circ}{X}_i \overset{\circ}{X}_j}(0)$ at time shift $\mu = 0$ of centered input useful signals $\overset{\circ}{X}_i(i\Delta t) = X_i(i\Delta t) - m_{X_i}$; $\left\| R_{\overset{\circ}{X}_i \overset{\circ}{Y}}(0) \right\|$ is column matrix of estimates of cross-correlation functions $R_{\overset{\circ}{X}_i \overset{\circ}{Y}}(0)$ at time shift $\mu = 0$ between centered input useful signal $\overset{\circ}{X}_i(i\Delta t)$ and output signal $\overset{\circ}{Y}(i\Delta t) = Y(i\Delta t) - m_Y$; m_{X_i} and m_Y are mathematical expectations of signals $X_i(i\Delta t)$ and $Y(i\Delta t)$ respectively;

$$R_{\dot{X}\dot{X}}(\mu) = \frac{1}{N} \sum_{k=1}^N \dot{X}(k\Delta t) \dot{X}((k+\mu)\Delta t)$$

$$R_{\dot{X}\dot{Y}}(\mu) = \frac{1}{N} \sum_{k=1}^N \dot{X}(k\Delta t) \dot{Y}((k+\mu)\Delta t)$$

However, due to noises $\varepsilon_i(t)$, $\varphi(t)$, which are imposed on useful input signals $X_i(t)$, $i = \overline{1, n}$, correlation matrix equation is transformed to the following form

$$\vec{R}_{gg}(0) \cdot \vec{B}^* = \vec{R}_{g\eta}(0)$$

where

$$\vec{R}_{gg}(0) = \left\| R_{g_i g_j}(0) \right\| = \begin{bmatrix} R_{g_1 g_1}(0) & R_{g_1 g_2}(0) & \dots & R_{g_1 g_n}(0) \\ R_{g_2 g_1}(0) & R_{g_2 g_2}(0) & \dots & R_{g_2 g_n}(0) \\ \dots & \dots & \dots & \dots \\ R_{g_n g_1}(0) & R_{g_n g_2}(0) & \dots & R_{g_n g_n}(0) \end{bmatrix}, \quad i, j = \overline{1, n}$$

$$\vec{R}_{g\eta}(0) = \left\| R_{g_i \eta}(0) \right\| = \begin{bmatrix} R_{g_1 \eta}(0) & R_{g_2 \eta}(0) & \dots & R_{g_n \eta}(0) \end{bmatrix}^T$$

Meanwhile, general dynamic identification problem is reduced to calculation of impulse transition function $k(\tau)$ or transfer function $W(\tau)$ as a result of certain kind of effect on the input and measuring the system response. Statistical methods of determining of transfer function or impulse transition function are based on the integral equation

$$R_{\dot{X}\dot{Y}}(\tau) = \int_0^{\infty} R_{\dot{X}\dot{X}}(\tau - \lambda) k(\lambda) d\lambda, \quad -\infty < \tau < \infty$$

which allows one, using correlation function $R_{\dot{X}\dot{X}}(\tau)$ of signal $X(t)$ at the input of the construction object and cross-correlation function $R_{\dot{X}\dot{Y}}(\tau)$ between the output $Y(t)$ and the input, to determine impulse transition function.

Assume that the construction object is in the normal state, and useful signals $X(t)$, $Y(t)$ are received from vibration, motion, tilt, deformation and other sensors. Then solving of statistical dynamic of the construction object can be reduced to solving of a system of equations, which looks as follows in matrix representation:

$$\vec{R}_{\dot{X}\dot{Y}}(\mu) = \vec{R}_{\dot{X}\dot{X}}(\mu) \vec{W}(\mu), \quad \mu = 0, \Delta t, 2\Delta t, \dots, (N-1)\Delta t$$

where $\vec{R}_{\dot{X}\dot{X}}(\mu)$ is square symmetric matrix of auto-correlation functions of dimension $N \times N$ of input signal $\dot{X}(t) = X(t) - m_X$; $\vec{R}_{\dot{X}\dot{Y}}(\mu)$ is column vector of cross-correlation functions between the input $\dot{X}(t)$ and output $\dot{Y}(t) = Y(t) - m_Y$, m_X , m_Y

are mathematical expectations of $X(t)$, $Y(t)$ respectively; $\vec{W}(\mu)$ is column vector of impulse transition function [3].

Correlation matrices $\bar{R}_{XX}(\mu)$, $\bar{R}_{XY}(\mu)$ and column vector of impulse transition functions $\vec{W}(\mu)$ in this case have the following:

$$\bar{R}_{XX}(\mu) = \begin{bmatrix} R_{XX}(0) & R_{XX}(\Delta t) & \dots & R_{XX}[(N-1)\Delta t] \\ R_{XX}(\Delta t) & R_{XX}(0) & \dots & R_{XX}[(N-2)\Delta t] \\ \dots & \dots & \dots & \dots \\ R_{XX}[(N-1)\Delta t] & R_{XX}[(N-2)\Delta t] & \dots & R_{XX}(0) \end{bmatrix}$$

$$\bar{R}_{XY}(\mu) = \begin{bmatrix} R_{XY}(0) & R_{XY}(\Delta t) & \dots & R_{XY}[(N-1)\Delta t] \end{bmatrix}^T$$

$$\vec{W}(\mu) = [W(0) \quad W(\Delta t) \quad \dots \quad W((N-1)\Delta t)]^T$$

When corresponding noises $\varepsilon(t)$, $\varphi(t)$ are imposed on useful signals $X(t)$, $Y(t)$, correlation matrices take the following form:

$$\bar{R}_{gg}(\mu) = \begin{bmatrix} R_{gg}(0) & R_{gg}(\Delta t) & \dots & R_{gg}[(N-1)\Delta t] \\ R_{gg}(\Delta t) & R_{gg}(0) & \dots & R_{gg}[(N-2)\Delta t] \\ \dots & \dots & \dots & \dots \\ R_{gg}[(N-1)\Delta t] & R_{gg}[(N-2)\Delta t] & \dots & R_{gg}(0) \end{bmatrix}$$

$$\bar{R}_{g\eta}(\mu) = \begin{bmatrix} R_{g\eta}(0) & R_{g\eta}(\Delta t) & \dots & R_{g\eta}[(N-1)\Delta t] \end{bmatrix}^T$$

Thus, dynamic identification problem, as well as static identification problem, is reduced to solving of a symmetric system of linear algebraic equations by means of correlation matrices. Let us therefore consider properties and specifics of correlation matrices in more detail.

Technology of building correlation matrices and their properties in problems of static and dynamic identification of technical condition and seismic stability of high-rise buildings and building structures

As is known, a correlation matrix is a matrix composed of estimates of auto- and cross-correlation functions.

In static identification problem, system $n \times n$ of correlation functions calculated at time shift $\mu = 0$ and placed in a rectangular table with n rows and n columns

$$\vec{R}_{gg}(0) = \begin{bmatrix} R_{g_1 g_1}(0) & R_{g_1 g_2}(0) & R_{g_1 g_3}(0) & \dots & R_{g_1 g_n}(0) \\ R_{g_2 g_1}(0) & R_{g_2 g_2}(0) & R_{g_2 g_3}(0) & \dots & R_{g_2 g_n}(0) \\ \dots & \dots & \dots & \dots & \dots \\ R_{g_n g_1}(0) & R_{g_n g_2}(0) & R_{g_n g_3}(0) & \dots & R_{g_n g_n}(0) \end{bmatrix}$$

ισ χαλλεδ α χορρελατιον στατιχ ματριξ. ροωσ ανδ χολυμνσ οφ τηε αβοπε μεντι ονεδ ματριξ αρε χαλλεδ σεριεσ οφ χορρελατιον ματριξ.

Normalized correlation static matrix is a matrix composed of normalized estimates of auto- and cross-correlation functions at time shift $\mu = 0$, i.e. of elements of the above mentioned matrix are divided by corresponding values of variances of parameters:

$$\vec{r}_{gg}^{\rightarrow}(0) = \begin{bmatrix} \frac{R_{g_1 g_1}^{\circ}(0)}{D(g_1)} & \frac{R_{g_1 g_2}^{\circ}(0)}{\sqrt{D(g_1) \cdot D(g_2)}} & \dots & \frac{R_{g_1 g_n}^{\circ}(0)}{\sqrt{D(g_1) \cdot D(g_n)}} \\ \frac{R_{g_2 g_1}^{\circ}(0)}{\sqrt{D(g_2) \cdot D(g_1)}} & \frac{R_{g_2 g_2}^{\circ}(0)}{D(g_2)} & \dots & \frac{R_{g_2 g_n}^{\circ}(0)}{\sqrt{D(g_2) \cdot D(g_n)}} \\ \dots & \dots & \dots & \dots \\ \frac{R_{g_n g_1}^{\circ}(0)}{\sqrt{D(g_n) \cdot D(g_1)}} & \frac{R_{g_n g_2}^{\circ}(0)}{\sqrt{D(g_n) \cdot D(g_2)}} & \dots & \frac{R_{g_n g_n}^{\circ}(0)}{D(g_n)} \end{bmatrix}$$

$$= \begin{bmatrix} r_{g_1 g_1}^{\circ}(0) & r_{g_1 g_2}^{\circ}(0) & \dots & r_{g_1 g_n}^{\circ}(0) \\ r_{g_2 g_1}^{\circ}(0) & r_{g_2 g_2}^{\circ}(0) & \dots & r_{g_2 g_n}^{\circ}(0) \\ \dots & \dots & \dots & \dots \\ r_{g_n g_1}^{\circ}(0) & r_{g_n g_2}^{\circ}(0) & \dots & r_{g_n g_n}^{\circ}(0) \end{bmatrix},$$

where $D(g_i), D(g_j)$ - ($i = 1, 2, \dots, n; j = 1, 2, \dots, n$) are variances of parameters.

In dynamic identification problem, system $n \times n$ of correlation functions calculated at all time shifts μ and placed in a rectangular table with n rows and n columns is called correlation dynamic matrix:

$$\vec{R}_{gg}^{\rightarrow}(\mu) = \begin{bmatrix} R_{g_1 g_1}^{\circ}(0) & R_{g_1 g_2}^{\circ}(\Delta t) & \dots & R_{g_1 g_n}^{\circ}[(N-1)\Delta t] \\ R_{g_2 g_1}^{\circ}(\Delta t) & R_{g_2 g_2}^{\circ}(0) & \dots & R_{g_2 g_n}^{\circ}[(N-2)\Delta t] \\ \dots & \dots & \dots & \dots \\ R_{g_n g_1}^{\circ}[(N-1)\Delta t] & R_{g_n g_2}^{\circ}[(N-2)\Delta t] & \dots & R_{g_n g_n}^{\circ}(0) \end{bmatrix}$$

Normalized correlation dynamic matrix is a matrix composed of normalized estimates of auto- and cross-correlation functions at all time shifts μ , i.e. of elements of the above mentioned matrix are divided by variance of corresponding parameter:

$$\vec{r}_{gg}^{\rightarrow}(\mu) = \begin{bmatrix} \frac{R_{g_1 g_1}^{\circ}(0)}{D(g_1)} & \frac{R_{g_1 g_2}^{\circ}(\Delta t)}{D(g_2)} & \dots & \frac{R_{g_1 g_n}^{\circ}[(N-1)\Delta t]}{D(g_n)} \\ \frac{R_{g_2 g_1}^{\circ}(\Delta t)}{D(g_1)} & \frac{R_{g_2 g_2}^{\circ}(0)}{D(g_2)} & \dots & \frac{R_{g_2 g_n}^{\circ}[(N-2)\Delta t]}{D(g_n)} \\ \dots & \dots & \dots & \dots \\ \frac{R_{g_n g_1}^{\circ}[(N-1)\Delta t]}{D(g_1)} & \frac{\sqrt{R_{g_n g_2}^{\circ}[(N-2)\Delta t]}}{D(g_2)} & \dots & \frac{\sqrt{R_{g_n g_n}^{\circ}(0)}}{D(g_n)} \end{bmatrix} =$$

$$= \begin{bmatrix} r_{gg}^{\circ}(0) & r_{gg}^{\circ}(\Delta t) & \dots & r_{gg}^{\circ}[(N-1)\Delta t] \\ r_{gg}^{\circ}(\Delta t) & r_{gg}^{\circ}(0) & \dots & r_{gg}^{\circ}[(N-2)\Delta t] \\ \dots & \dots & \dots & \dots \\ r_{gg}^{\circ}[(N-1)\Delta t] & r_{gg}^{\circ}[(N-2)\Delta t] & \dots & r_{gg}^{\circ}(0) \end{bmatrix}$$

where $D(g_i) D(g_j) (i=1,2,\dots,n \quad j=1,2,\dots,n)$ are variances of parameters.

Correlation functions $\vec{R}_{g_i g_j}^{\circ}(0)$, $(i=1,2,\dots,n; j=1,2,\dots,n)$ and $\vec{R}_{gg}^{\circ}(\mu)$ $(\mu=0,1,2,\dots,N)$ composing above mentioned matrices respectively are called elements of correlation matrices.

Elements of normalized correlation matrices above mentioned respectively $r_{g_i g_i}^{\circ}(0)$, is auto-correlation function, $r_{g_i g_j}^{\circ}(\mu)$ is cross-correlation function. Here, the first index i represents the number of element row, and the second j is the number of its column.

For correlation above mentioned matrices abridged notations are often used:

$$\vec{R}_{gg}^{\circ}(0) = \left[R_{g_i g_j}^{\circ}(0) \right] (i=1,2,\dots,n; j=1,2,\dots,n), \quad \vec{R}_{gg}^{\circ}(\mu) = \left[R_{gg}^{\circ}(\mu) \right], \quad (\mu=0,1,2,\dots,N).$$

Such a matrix, where $n = n$, is called a square matrix of n order. In particular, correlation matrix of $1 \times n$ type is called a row vector, and correlation matrix of $n \times 1$ type is called a column vector.

In solving of static identification problems, when there is no correlation between parameters g_i and g_j , correlation matrix has the following form:

$$\vec{R}_{gg}^{\circ}(0) = \begin{bmatrix} R_{g_1 g_1}^{\circ}(0) & 0 & 0 & \dots & 0 \\ 0 & R_{g_2 g_2}^{\circ}(0) & 0 & \dots & 0 \\ \dots & \dots & \dots & \dots & \dots \\ 0 & 0 & 0 & \dots & R_{g_n g_n}^{\circ}(0) \end{bmatrix}$$

and is called a diagonal matrix. Diagonal normalized correlation matrix will have the following form in solving of static identification problems:

$$\vec{r}_{gg}^{\circ}(0) = \begin{bmatrix} \frac{R_{g_1 g_1}^{\circ}(0)}{D(g_1)} & 0 & \dots & 0 \\ 0 & \frac{R_{g_2 g_2}^{\circ}(0)}{D(g_2)} & \dots & 0 \\ \dots & \dots & \dots & \dots \\ 0 & 0 & \dots & \frac{R_{g_n g_n}^{\circ}(0)}{D(g_n)} \end{bmatrix}$$

where sum is applied to all possible permutations $R_{g_1 g_{i_1}}(0), R_{g_2 g_{i_2}}(0), \dots, R_{g_n g_{i_n}}(0)$ of elements $1, 2, \dots, n$ and therefore contains $n!$ summands, with $\chi = 0$, if permutation is even and $\chi = 1$, if permutation is odd.

By norm of correlation matrix $\vec{R}_{gg}(0) = [R_{g_i g_j}(0)]$ is meant a real number $\|\vec{R}_{gg}(0)\|$, complying with the following conditions:

$$\begin{aligned} \|\vec{R}_{gg}(0)\| &\geq 0, \text{ and } \|\vec{R}_{gg}(0)\| = 0 \text{ only when } \vec{R}_{gg}(0) = 0; \\ \|\alpha(\vec{R}_{gg}(0))\| &= |\alpha| \|\vec{R}_{gg}(0)\| \quad (\alpha - \text{a number}) \text{ and, in particular,} \\ \|\vec{-R}_{gg}(0)\| &= \|\vec{R}_{gg}(0)\|; \\ \|\vec{R}_{gg}(0) + B\| &\leq \|\vec{R}_{gg}(0)\| + \|B\|; \\ \|(\vec{R}_{gg}(0))B\| &\leq \|\vec{R}_{gg}(0)\| \cdot \|B\|; \end{aligned}$$

By norm of correlation matrix $\vec{R}_{gg}(\mu) = [\vec{R}_{gg}(\mu)]$ is meant a real number $\|\vec{R}_{gg}(\mu)\|$, complying with the following conditions:

$$\begin{aligned} \|\vec{R}_{gg}(\mu)\| &\geq 0, \text{ and } \|\vec{R}_{gg}(\mu)\| = 0 \text{ only when } \vec{R}_{gg}(\mu) = 0; \\ \|\alpha(\vec{R}_{gg}(\mu))\| &= |\alpha| \|\vec{R}_{gg}(\mu)\| \quad (\alpha - \text{a number}) \text{ and, in particular,} \\ \|\vec{-R}_{gg}(\mu)\| &= \|\vec{R}_{gg}(\mu)\|; \\ \|\vec{R}_{gg}(\mu) + B\| &\leq \|\vec{R}_{gg}(\mu)\| + \|B\|; \\ \|\vec{R}_{gg}(\mu)B\| &\leq \|\vec{R}_{gg}(\mu)\| \cdot \|B\|; \end{aligned}$$

By norm of normalized correlation matrix $\vec{r}_{gg}(0) = [\vec{r}_{g_i g_j}(0)]$ is meant a real number $\|\vec{r}_{gg}(0)\|$, complying with the following conditions:

$$\begin{aligned} \|\vec{r}_{gg}(0)\| &\geq 0, \text{ and } \|\vec{r}_{gg}(0)\| = 0 \text{ only when } \vec{r}_{gg}(0) = 0; \\ \|\alpha(\vec{r}_{gg}(0))\| &= |\alpha| \|\vec{r}_{gg}(0)\| \quad (\alpha - \text{a number}) \text{ and, in particular,} \\ \|\vec{-r}_{gg}(0)\| &= \|\vec{r}_{gg}(0)\|; \end{aligned}$$

$$\left\| \vec{r}_{gg}(0) + B \right\| \leq \left\| \vec{r}_{gg}(0) \right\| + \|B\|;$$

$$\left\| \left(\vec{r}_{gg}(0) \right) B \right\| \leq \left\| \vec{r}_{gg}(0) \right\| \cdot \|B\|;$$

By norm of normalized correlation matrix $\vec{r}_{gg}(\mu) = [\vec{r}_{gg}(\mu = i\Delta t)]$ is meant a real number $\|\vec{r}_{gg}(\mu)\|$, complying with the following conditions:

$$\text{a) } \left\| \vec{r}_{gg}(\mu) \right\| \geq 0, \text{ and } \left\| \vec{r}_{gg}(\mu) \right\| = 0 \text{ only when } \vec{r}_{gg}(\mu) = 0;$$

$$\left\| \alpha \left(\vec{r}_{gg}(\mu) \right) \right\| = |\alpha| \left\| \vec{r}_{gg}(\mu) \right\| \quad (\alpha - a \text{ number}) \text{ and, in particular,}$$

$$\left\| -\vec{r}_{gg}(\mu) \right\| = \left\| \vec{r}_{gg}(\mu) \right\|;$$

$$\left\| \vec{r}_{gg}(\mu) + B \right\| \leq \left\| \vec{r}_{gg}(\mu) \right\| + \|B\|;$$

$$\left\| \left(\vec{r}_{gg}(\mu) \right) B \right\| \leq \left\| \vec{r}_{gg}(\mu) \right\| \cdot \|B\|;$$

$R_{gg}(0), R_{gg}(\mu), r_{gg}(0), r_{gg}(\mu)$ and B are matrices, for which corresponding operation make sense. For square matrix in particular, we have

$$\left\| \left(\vec{R}_{gg}(0) \right)^p \right\| \leq \left\| \left(\vec{R}_{gg}(0) \right) \right\|^p$$

$$\left\| \left(\vec{R}_{gg}(\mu) \right)^p \right\| \leq \left\| \left(\vec{R}_{gg}(\mu) \right) \right\|^p$$

$$\left\| \left(\vec{r}_{gg}(0) \right)^p \right\| \leq \left\| \left(\vec{r}_{gg}(0) \right) \right\|^p$$

$$\left\| \left(\vec{r}_{gg}(\mu) \right)^p \right\| \leq \left\| \left(\vec{r}_{gg}(\mu) \right) \right\|^p$$

where p is a natural number.

For correlation matrices $\vec{R}_{gg}(0) = [R_{gg}(0)_{ij}]$, $\vec{R}_{gg}(\mu) = [R_{gg}(\mu)_{ij}]$ and normalized correlation matrices $\vec{r}_{gg}(0) = [r_{gg}(0)_{ij}]$, $\vec{r}_{gg}(\mu) = [r_{gg}(\mu)_{ij}]$, basically three easily calculated norms are considered:

$$\left\| \vec{R}_{gg}(0) \right\|_m = \max_i \sum_j |R_{gg}(0)_{ij}| \quad (m\text{-norm});$$

$$\left\| \vec{R}_{gg}(\mu) \right\|_m = \max_i \sum_j |R_{gg}(\mu)_{ij}| \quad (m\text{-norm});$$

$$\left\| \vec{r}_{gg}(0) \right\|_m = \max_i \sum_j |r_{gg}(0)_{ij}| \quad (m\text{-norm});$$

$$\begin{aligned} \left\| \vec{r}_{gg}(\mu) \right\|_m &= \max_i \sum_j |r_{gg}(\mu)_{ij}| \quad (m\text{-norm}); \\ \left\| \vec{R}_{gg}(0) \right\|_l &= \max_j \sum_i |R_{gg}(0)_{ij}| \quad (l\text{-norm}); \\ \left\| \vec{R}_{gg}(\mu) \right\|_l &= \max_j \sum_i |R_{gg}(\mu)_{ij}| \quad (l\text{-norm}); \\ \left\| \vec{r}_{gg}(0) \right\|_l &= \max_j \sum_i |r_{gg}(0)_{ij}| \quad (l\text{-norm}); \\ \left\| \vec{r}_{gg}(\mu) \right\|_l &= \max_j \sum_i |r_{gg}(\mu)_{ij}| \quad (l\text{-norm}); \\ \left\| \vec{R}_{gg}(0) \right\|_k &= \sqrt{\sum_{i,j} |R_{gg}(0)_{ij}|^2} \quad (k\text{-norm}); \\ \left\| \vec{R}_{gg}(\mu) \right\|_k &= \sqrt{\sum_{i,j} |R_{gg}(\mu)_{ij}|^2} \quad (k\text{-norm}); \\ \left\| \vec{r}_{gg}(0) \right\|_k &= \sqrt{\sum_{i,j} |r_{gg}(0)_{ij}|^2} \quad (k\text{-norm}); \\ \left\| \vec{r}_{gg}(\mu) \right\|_k &= \sqrt{\sum_{i,j} |r_{gg}(\mu)_{ij}|^2} \quad (k\text{-norm}). \end{aligned}$$

Thus, reliable prediction of technical condition of a high-rise building or building structure requires application of the correlation matrices described above, which makes it possible to solve problems of control, monitoring, identification, predication, diagnostics and detection of malfunction at early stages.

References

- [1] Suschev S.P. Monitoring of stability and residual life of high-rise buildings and structures with application of "Strela" mobile diagnostics complex. Unique and special technologies in construction (UST-Build 2005). M.: CNTCMO. 2005, pp. 68-71.
- [2] Telman Aliev. Digital Noise Monitoring of Defect Origin. — London: Springer, 2007, 235 p.
- [3] Telman Aliev. Robust Technology with Analysis of Interference in Signal Processing. — New York: Kluwer Academic/Plenum Publishers, 2003, 199 p.
- [4] Aliev T.A., Musaeva N.F., Guluyev G.A., Sattarova U.E. Noise Indication of Change of Dynamical Condition of Production Objects // Mechatronics, automation, control, №8, 2011, pp. 2-5.
- [5] Aliev T.A., Musaeva N.F., Guluyev G.A., Sattarova U.E. *Noise Technology of Indication and Identification of the Latent Period of Transition of an Object from a Normal Condition to an Emergency One* // Mechatronics, automation, control, №9, 2010, pp. 13-18.

- [6] T.A. Aliev, G.A. Guluyev, A.H. Rzayev, F.H. Pashayev. Correlated indicators of microchanges in technical state of control objects. *Cybernetics and Systems Analysis*, Springer New York, No.4, 2009, pp. 655-662.
- [7] T.A. Aliev, A.M. Abbasov, G.A. Guluyev, A.H. Rzayev, F.H. Pashayev. Positionally-binary and spectral indicators of microchanges in technical conditions of objects of the control. *Automatic Control and Computer Sciences*, Allerton Press, Inc., New York, No.3, 2009, p.p. 156-165.
- [8] Musaeva N.F. Methodology of calculating robustness as an estimator of the statistical characteristics of a noisy signal, *Automatic Control and Computer Sciences*, Allerton Press, Inc., New York (2005), Vol. 39, No.5, pp. 53–62.

21. UNIVERSITIES IN FACILITATING TRANSFER OF SCIENCE AND TECHNOLOGY IN ENERGY EFFICIENCY

*Prof. Dr. V. Shvets*¹, *Assoc. Prof. Dr. L. Palekhova*², *Assoc. Prof. Dr. T. Yakovenko*³

State Higher Educational Institution “National Mining University”,
Dnipro, Ukraine, <http://www.nmu.org.ua/en/>

ABSTRACT

Global energy crisis has significantly undermined Ukrainian industry, which is the basis of its national economy. For many years, energy intensity in the Ukrainian industrial sector has the highest level in the world. This article focuses on the study of integration of energy efficiency concept into non-environmental study programmes at technical universities.

Keywords: *sustainable development, higher education, educational programs, international cooperation between universities.*

Main text:

It is argued that energy efficiency today is the essential element of green economy. At the same time, energy factor is usually considered as operating resource without paying attention to its social and ecological function. As a result, Ukrainian students, in particular in Economics, are not provided with knowledge and skills relative to indicators and assessment of energy efficiency for application in management decisions [1].

Lately the most CIS countries had agreed with the need for fundamental reforms of national system of higher education, and currently they are developing an appropriate policy. The role of HEIs is in formation of a new staffing resources or “critical mass” of well-trained and motivated managers, who will make a valuable contribution to the adoption of in-house energy-efficient and sustainable management policies and systems. Reforms of higher education for sustainable society development are set out in the basic programming documents adopted by the governments. Thus, a new Law of Ukraine "On Higher Education" (Version of 09.08.2016) establishes a general outline of the State policy in the field of higher education, based on the principles of sustainability, among which the first and the most important task is: “the promotion of sustainable development through producing a competitive human capital, and creation of conditions for lifelong learning” [2].

In this regard, scientists and specialists have been developing the procedure of making educational process more consistent with European principles and standards. Authors point out that universities should become the “smithy of staff” for moving to wise practices on environment and energy resources management, including the application of energy efficient solutions and environmentally sustainable economic growth approach [3].

However, it should be noted that universities pay so far little or no attention to adaptation of the economical education programs for changing energy requirements of the economy. In particular, specific studies had also confirmed that Ukrainian universities are not paying attention to gaps in knowledge and formation of specific “sustainability and energy mindset” of future managers and non-core specialists (economists, marketers, etc.) [3]. And the required tools for putting these objectives in practice are not clearly described.

At the same time, a number of recent international forums on education for sustainable development explained the vision of related tasks. UNESCO World Conference on Education for Sustainable Development (Aichi-Nagoya, Japan, 10-12 November 2014) and World Education Forum (Incheon, Korea, 19-22 May 2015) emphasized that the transformation of higher education should be comprehensive and multifaceted, also cover the content of educational programs, educational methods and techniques, learning environment and learning outcomes.

Moreover, the Paris Agreement on Climate Change (United Nations Framework Convention on Climate Change, 30 November-12 December 2015) calls upon all Parties to ensure that issues of climate and energy saving are adequately reflected in education and training as their contribution to capacity building for climate action.

In this context, Figure 1 shows the vision of implementation of sustainable development and energy efficiency ideas in the education process in economics.

Content of educational programs in economics – all curricula should include a sufficient range of themes and issues, which are crucial for understanding of sustainability and energy efficiency at the global and local levels (such as the principle of energy efficiency development, the objectives of energy efficiency in management, methods and tools for measuring sustainability and energy efficiency assessment, international energy management standards, etc.).

Educational methods and techniques – methods and teaching practice should contribute to the improvement of education quality and the formation of a new administrative staffs and managers generation through stimulating innovatory efforts in the learning and training process (like integration of formal and informal education, development of students' mindset based on the model “challenge - comprehension - responsibility for sustainable development and energy efficiency - well-reasoned decisions”, dialogic learning and effective learning communication, etc.).

Learning environment in economics includes two levels of reform:

- (1) Upgrading diverse educational environment (*physical, virtual and online*) as a most effective tools of facilitating the assimilation of systematic and relevant knowledge on sustainable development and energy efficiency.
- (2) Encouraging acquisition and exchange of scientific and professional knowledge, and narrowing the knowledge gaps on methods and tools for sustainable management with special focus on the rational use of energy resources.

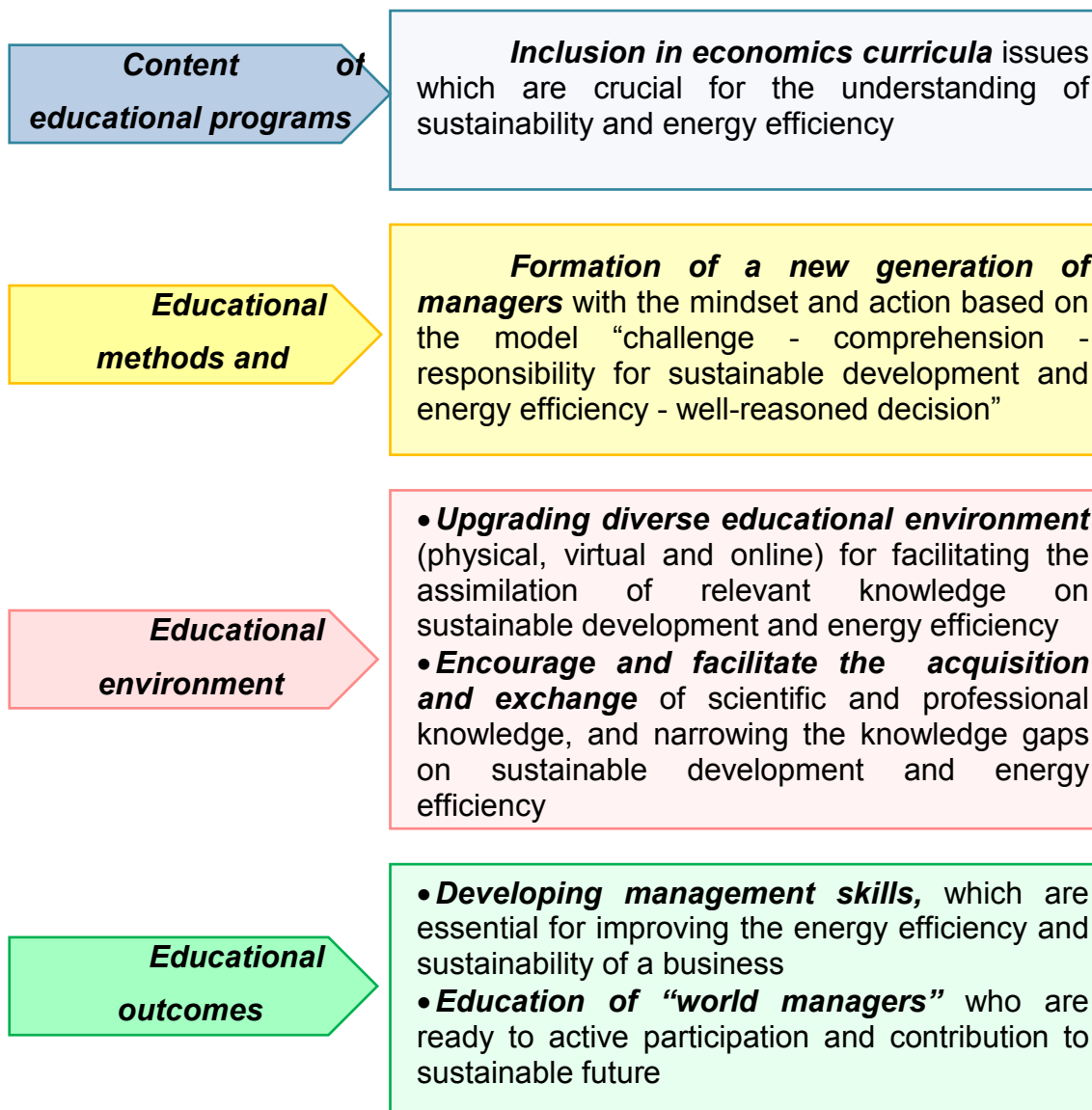

Fig. 1. The implementation process of the energy efficiency and sustainability aspects to educational programs in economics (Source: compiled by the authors based on [3-5])

Educational outcomes include two subsequent levels:

- (1) Developing management skills which are essential for improving the energy efficiency and sustainability of a business.
- (2) Education of managers who are ready to active participation and contribution to sustainable future.

The integration of energy efficiency concept has to be supported by new methods and principles of education, which ensure training of specialists with mindset of energy efficiency and sustainable development (Fig. 2).

Multidisciplinary
and holistic approach

➔ The principles of sustainable development and energy efficiency have to run through educational programs other than to be a single subjects

Integration of formal and
informal education

➔ Educational methods, tools and means for application the best practices of sustainable development and energy efficiency

Developing critical thinking

➔ Developing critical thinking for the students which will help them to keep an open mind for applying principles of sustainable development and energy efficiency to their decisions

Participatory approach

➔ Educational methods presuppose a dialog between teacher and students (other than influence) for developing thinking on solutions to professional tasks adjusted to the principles of sustainable development and energy efficiency

Multiplicative useful effect

➔ Teaching and educational methods should ensure real competitive advantages for the student's recruitment

Fig. 2. Educational and teaching methods in the context of sustainable development and energy efficiency problems (Source: compiled by the authors based on [2])

Integration of energy efficiency concept into educational process in management has to be provided in two directions: including of special

disciplines (for example, disciplines on energy efficiency standards) and integration of energy efficiency aspects into core disciplines (compulsory and optional) [4]. Provided approach will give to managers the opportunity to make well-reasoned decisions and to act responsibly for efficient use of resources, ensuring profitability and energy efficiency, and keeping principles of just society for considering the interests of present and future generations.

References

- [1] Shvets V., Palekhova L., Palekhov D., Ivannikov A. (2014) *Implementation of sustainable development ideas into economics curriculum*. In: *Economics Bulletin*, № 2 (46), pp. 114-119. ISSN 2073-9982
(In Russian: Шве́ц В.Я., Палехова Л.Л., Палехов Д.А., Иванников А.Л. (2014) *Имплементация идей устойчивого развития в учебные программы студентов экономических специальностей // Экономічний вісник*, № 2, С. 114-119. ISSN 2073-9982)
- [2] Law of Ukraine “On Higher Education” (Version of 09.08.2016) - <http://zakon5.rada.gov.ua/laws/show/1556-18> (accessed November 16, 2016).
(In Ukrainian: Закон України “Про вищу освіту” (Редакція від 09.08.2016). – <http://zakon5.rada.gov.ua/laws/show/1556-18> (обращение 16 ноября 2016).
- [3] Schmidt M., Palekhov D., Shvets V., Palekhova L., 2015: *Changing the paradigm of higher education for sustainable development*. In: *Management for sustainable developments in transitional economies: Monograph*. Dnepropetrovsk-Cottbus: NMU-BTU, pp. 365-378. ISBN 978-617-7109-91-3
(In Russian: Шмидт М., Палехов Д., Шве́ц В., Палехова Л., 2015: *Изменение парадигмы высшего образования для целей устойчивого развития // Управление устойчивым развитием в условиях переходной экономики: монография*. – Днепропетровск-Коттбус: НГУ-БТУ, С. 365-378. ISBN 978-617-7109-91-3)
- [4] Shvets V., Palekhova L., Schmidt M., Palekhov D., 2015: *The experience of international universities partnerships in the field of greening education and the development of distance online learning*. In: *Innovation in higher education - communication and collaboration in a modern university environment with specific digital tools: [international collective monograph]*. Ed.: Prof. Nakaznoy M.O. Dneprodzerzhinsk: DSTU, pp.170-181.
(In Ukrainian: Шве́ц В., Палехова Л., Шмидт М., Палехов Д., 2015: *Опыт международного партнерства университетов в сфере экологизации образования и развития дистанционного онлайн обучения // Інновації у вищій освіті – комунікація та співпраця у сучасному університетському середовищі за допомогою специфічних цифрових інструментів: [Міжнародна колективна монографія]. За заг. ред. проф. Наказного М.О. Дніпродзержинськ: ДДТУ, С.170-181)*
- [5] Shvets V., Palekhova L., Schmidt M., Palekhov D. (2015) *Partnership as a method of promoting a model of higher education for sustainable development*. In: *Economics Bulletin*, № 3 (51), pp. 146-154. ISSN 2071-2227
(In Russian: Шве́ц В., Палехова Л., Шмидт М., Палехов Д. (2015) *Партнерство как метод продвижения модели высшего образования для целей устойчивого развития // Экономічний вісник*. № 3 (51), С. 146-154)

Contacts:

¹Prof. Dr. V. Shvets ²Assoc. Prof. Dr. L. Palekhova, ³Assoc. Prof. Dr. T. Yakovenko

Affiliation: SHEI "National Mining University", Dnipro, Ukraine

E-Mail: ¹vasil-shvets@ukr.net, ²palehovall@gmail.com, ³yakovenkotatiana777@gmail.com

22. MANAGING THE SUSTAINABLE DEVELOPMENT OF URBAN SYSTEM IN THE CONTEXT OF EUROPEAN INTEGRATION

Prof. Dr. Artem Bardas¹, Assoc. Prof. Alla Dudnyk

State Higher Educational Institution “National Mining University”,
Dnipro, Ukraine, <http://www.nmu.org.ua/en/>

ABSTRACT

The article deals with problem of sustainable development of urban systems, analyzes the problem of the transformation of environment in cities, and discusses the methodological approaches to estimate environmental safety impact on economic and social indicators of a city sustainable development.

As we accept that the main question of sustainable development is to balance human needs with environmental safety, we also have to take the point that cities have transformed into such places where destruction of natural environment proceeds at a high pace.

Keywords: *sustainable development, urban systems, urbanization, environmental safety.*

Main text:

When signing the EU-Ukraine Association Agreement the both sides have recognized Agenda 21 – Sustainable Development Knowledge Platform 1992, Johannesburg Plan of Implementation for Sustainable Development 2002 and internationally agreed policy programs in the fields of employment, social policy and environmental protection to contribute towards the goal of sustainable development and to ensure that this objective is integrated and displayed at every level of mutual relations.

The model of an urban system sustainable development is, like any other models, an integrated system, which components represent main ideas of sustainable evolution of social, economic and environmental processes. There are a number of baselines for implementation of sustainable development principles in a policy at different level of public administration [1]:

- economic development based upon radical modified market interactions;
- natural and environmental sustainability based on biotic regulation;
- international cooperation in politic, social and economic policies;
- sustainable social development based on welfare and equality;
- ecologization of social consciousness be means of mass media and life-long learning system.

As we accept that the main question of sustainable development is to balance human needs with environmental safety, we also have to take the point that cities have transformed into such places where destruction of natural environment proceeds at a high pace.

Understanding the co-evolution of urban and natural systems is key to build a resilient society and transform our habitat. Cities mainly are going to be

developed in places that are the most biologically diverse, but the urbanization affects negatively not only landscapes, but pollutes water sources and air, destroys greenery. While concentrating a huge amount of people on comparatively small areas, most of the cities are known as so-called “demographic black holes” [2]. For instance, in Ukraine has been a strong trend of increasing the number of urban population since 1960; however, the trend become always linear since 2005 as it shown the Figure 1.

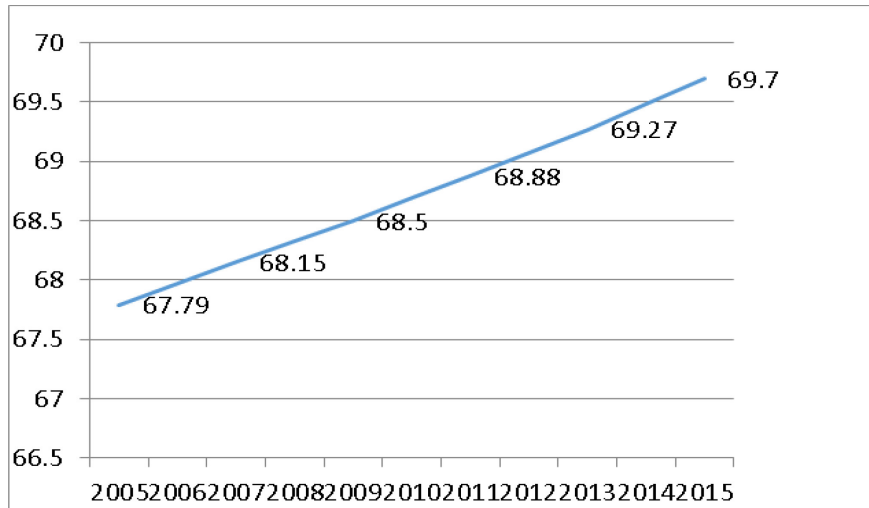

Fig. 1. Level of urbanization in Ukraine, % of urban population [3].

Ukraine's demographic outlook has changed from a country with a modestly high birth rate to one with more rapid aging and a smaller number of young people [2]. During more than three decades, until the middle of 1980, Ukraine's total fertility rate (TFR) was two children or more per woman. This indicator has been shrinking in cities since 1970th and now remains one of the world lowest – 1.5 TFR in 2013 [2].

The changes in crude birth rates, since 1970 until 2012, are shown in Figure 2. Concurrently with decline of crude birth rate the crude death rate has been growing in Ukraine as it shown at Figure 3.

Such a situation has been caused by not only social and economic factors. The birth rates are higher in rural regions and are lower in big cities and urbanized areas. These indicators seem to be worse in the industrialized southern and eastern regions of our country with the highest technogenic impacts on natural environment. This situation is not unique - many industrialized and developed nations have the same negative trends in demography. The specific of Ukraine is rather in a combination of a number of negative factors which are typical both for developed (low birth rate, the social model of consumerism) and developing countries (high levels of pollution of the natural environment, multi-faceted predatory attitude to natural resources, high crude death rate).

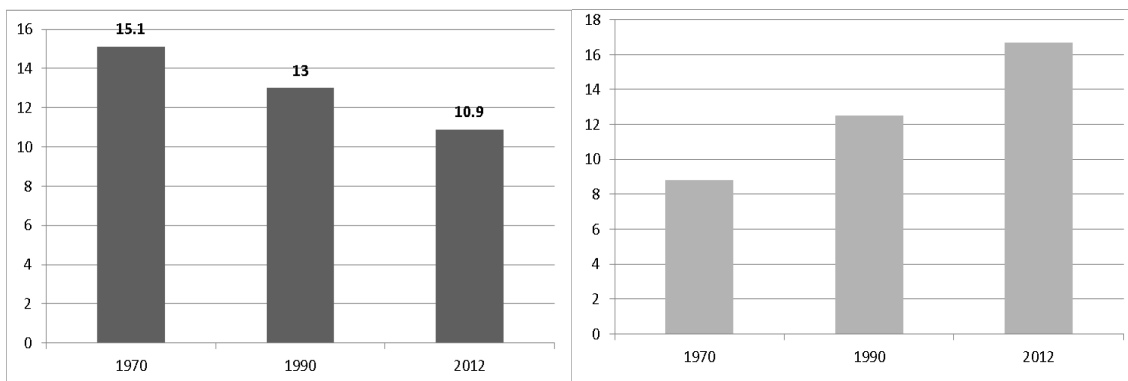

Fig.2. Crude birth rate in Ukraine, 1970-2012, per 1000 people [3].

Fig.3. Crude death rate dynamics in Ukraine, 1970-2012, per 1000 people [3].

Overcoming of the current trends is a matter of survival for contemporary Ukrainian society, a necessary condition to maintain its global competitiveness and adapt itself for different challenges. Considering the fact that most of the environmental risks are generated in urban areas - in megalopolises or industrial agglomerations - we need to improve our urban planning and design, enhance the quality of local governments and manage environmental pressures in a better way.

Reforms of urban planning need to separate industrial zones from residential areas develop flexible zoning. Dangerous productions must be removed from urban areas with high density of population and relocated to industrial zones, where risks of technological accidents would be lesser.

It would improve the ecological safety of urban systems. Linking transport infrastructure to residential areas, business and production centers, promotion coordination among metropolitan cities and their satellites would encourage better management of pollution.

The problems described above are not only inherent for Ukraine but have the global scale. As we can see, many developing countries in Africa and Asia have the highest increasing rates of urbanization, as there in 2030 urban population expected to increase up to 54% (in 1.45 times to 2000) and 55% (in 1.49 times to 2000) respectively [4].

World Health Organization has been monitoring on 2,000 cities and based on the gathered figures it affirms that pollution worsening in many countries. It was found that 15 out of the 20 most polluted places were in India and China. The others were in Pakistan, Iran and Bangladesh.

Of the worst 100, nearly 70 were in Asia and only a handful in Europe or the US. Unfortunately, the study did not cover those cities located in the Eastern Europe, like Kamianske, Dnipro, Kryvyi Rih and others, where pollution levels are extremely high and very dangerous for population.

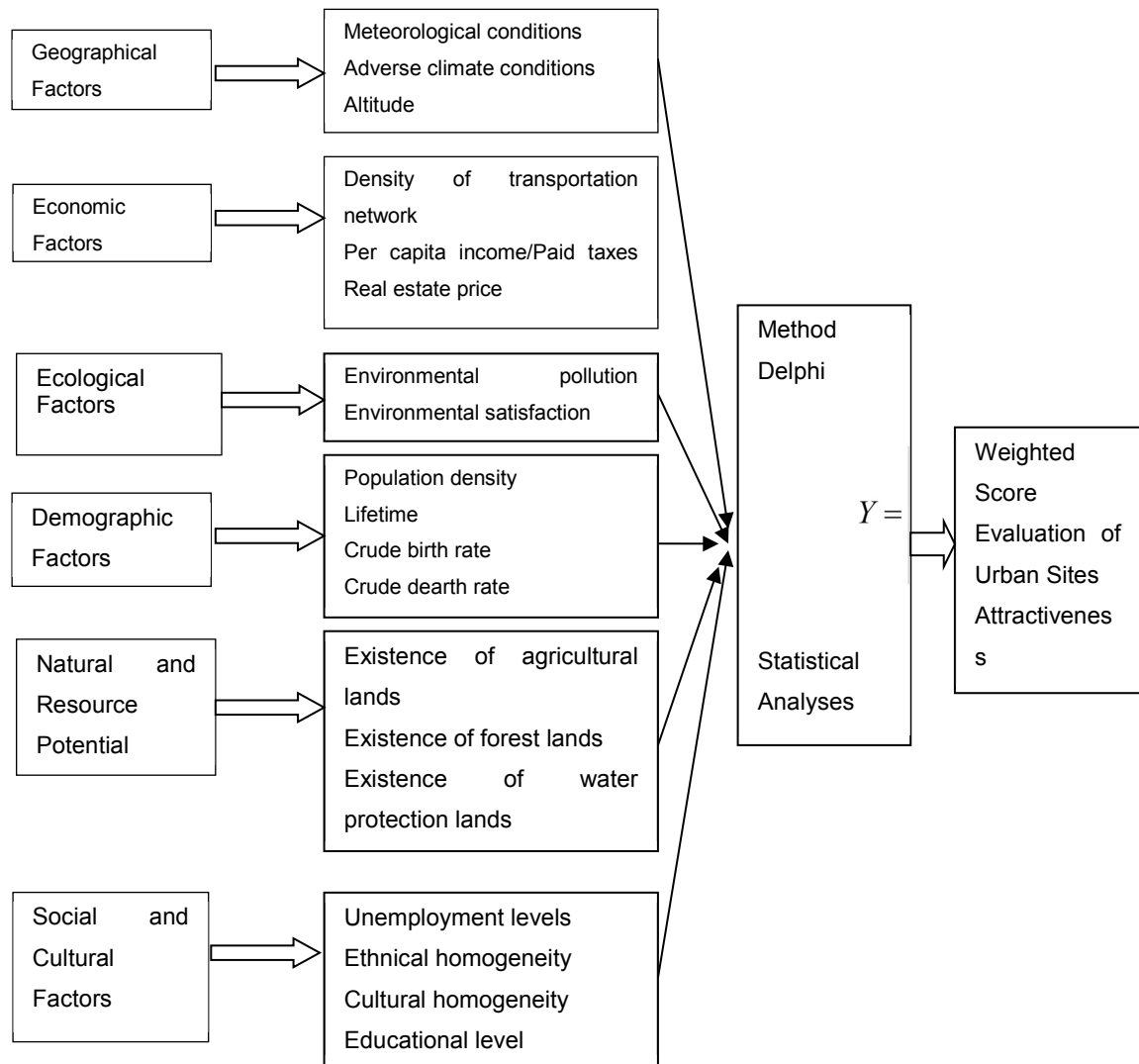

Fig.4. Methodological Approach for Evaluation the Attractiveness of an Urban Territory [5].

According to a recent WHO study, the cost of disease and the premature deaths caused in Europe every year by air pollution was more than \$1.6trillion in 2010, nearly 10% of the gross domestic product of the EU in 2013, while the UK was estimated to have suffered \$83bn (£54bn) in costs associated with air pollution [6]. Elsewhere in Europe, the figures were Germany \$145bn, and France \$53bn. The highest was in Bulgaria, which spent an estimated 29.5% of its GDP on the costs of air pollution fatalities [6].

If traditional concept of city development explained the worsening of urban environment by necessity of economic growth then modern theories of city's sustainable development pay more attention to creation of safety and resilient urban system, which satisfy both economic, social and ecological demands of local inhabitants. It is possible to do it under condition that local societies must find a consensus over main prospects of city development and create conditions for sustainable economic development of urban systems.

The prestige and international status of cities, prosperity of their citizens, as well as quality of infrastructure and services, depends on this ability to develop sustainably. In our study we are going to find some dependences between a number of social, economic, environmental factors and the attractiveness of

land plots in different districts of a city area. This study is considered a basement for developing a methodological approach, which aimed to help local authorities to estimate an impact of environmental safety on economic and social indicators of a city sustainable development.

References

- [1] *National Paradigm of Sustainable Development of Ukraine, 2016. State Establishment "Institute of Environmental Economics and Sustainable Development of National Academy of Sciences of Ukraine"*.
- [2] *Haub C. Ukraine's Demographic Reality. - <http://www.prb.org/Publications/Articles/2014/ukraine-population.aspx>(accessed October 4, 2016).*
- [3] *UNESCO. - <http://en.unesco.org/countries/ukraine> (accessed October 4, 2016).*
- [4] *World Urbanization Prospects. - <https://esa.un.org/unpd/wup/Publications/Files/WUP2014-Highlights.pdf> (accessed August 20, 2016).*
- [5] *Bardas A., Dudnyk A. To The Problem Of Evaluation Of Natural Resources Potential And Environmental Quality In Urban Settlements / A. Bardas, A. Dudnyk // Economic Bulletin of National Mining University. - 2016, №1 – P.148-155.*
- [6] *John Vidal. Air Pollution: a Dark Cloud of Filth poisons the World's Cities. The Guardian. – <https://www.theguardian.com/global-development/2016/jan/16/winter-smog-hits-worlds-cities-air-pollution-soars> (accessed October 4, 2016).*

Contacts:

¹Prof. Dr. Artem Bardas

Affiliation: SHEI "National Mining University", Dnipro, Ukraine

E-Mail: bardas_artem@ukr.ne

23. EXPERIENCE OF USING VOLUNTARY SUSTAINABLE DEVELOPMENT STANDARDS IN ENERGY SPHERE

Assoc. Prof. Dr. Tetiana Yakovenko¹, Assoc. Prof. Dr. Ludmila Palekhova²

State Higher Educational Institution “National Mining University”,
Dnipro, Ukraine, <http://www.nmu.org.ua/en/>

ABSTRACT

The main objective of this article was to study the practical aspects of implementing international energy standards as strategic tools to achieve the desired progress in the steel industry. The study highlighted that the overall goal is to ensure ‘energy efficiency’, ‘environmental sustainability’ and ‘energy equity’ as a single, unitary purpose and energy policy action programs. The immediate directions in the energy policy of steel plants will be the following: implementation of the development standards on energy saving and energy efficiency, reduction in GHG emissions by energy efficiency technologies, pursuit of competitive and transparent energy activity.

Keywords: *sustainable development, energy efficiency, voluntary energy standards.*

Main text:

The voluntary energy standards are recommended for management decisions toward implementation of sustainability principles at the different levels of the value chain, ranging from research and development to production and distribution [1]. The priority form of conformity according to international energy standards is a voluntary certification scheme, which is carried out to establish a control mechanism for compliance with energy efficiency criteria in production and management [2].

Recent literature on energy issues and sustainable development clearly demonstrated that energy certification should not be viewed only as a cost, but as a promising investment project, opening up new business opportunities. Voluntary energy certification is a procedure which confirms the compliance of the certified facility (products or management) with the requirements defined by the international standards on energy sustainability; this will allow us to overcome a crisis trend in energy-intensive industry sectors [3-4].

As for Ukraine, for many years country firmly occupies a leading position in the world ranking of energy intensity of the industrial sector. In 2015, the unit consumption of steel industry in Ukraine is 0.59, in Russia – 0.76, while for Germany – 0.31 (See Fig. 1-2).

Today, in energy sustainability index (calculated by the World Energy Council) among 125 countries Ukraine took the 63th place, Russia – 45th place, and Germany – 5th place (see Fig. 3-4).

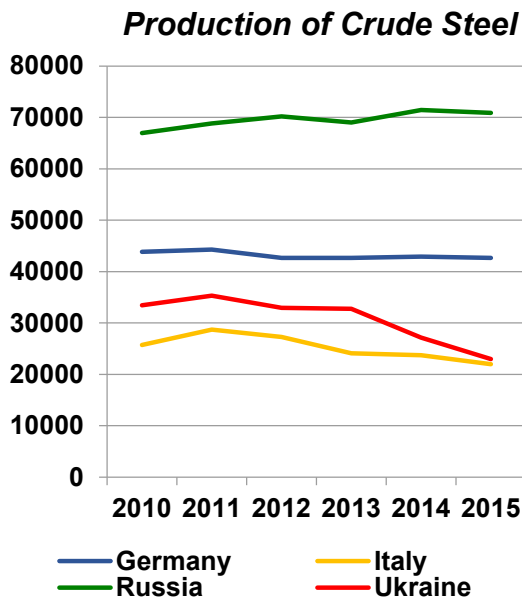

Fig.1 Total production of crude steel (Includes all qualities: carbon, stainless, and other alloy; in thousand metric tons) (Source: own compilation based on [5-6])

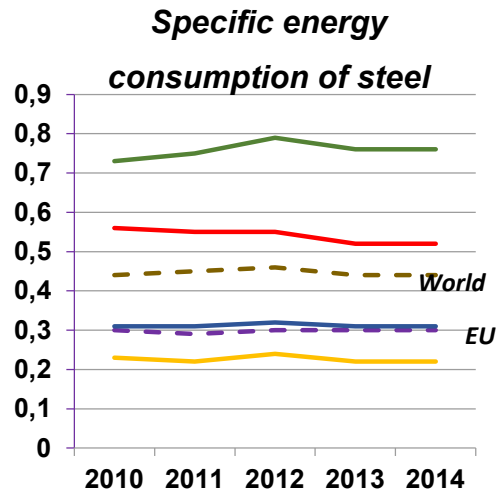

Fig.2. Specific energy consumption in the steel industry by countries (toe/t) (Source: own compilation based on [7])

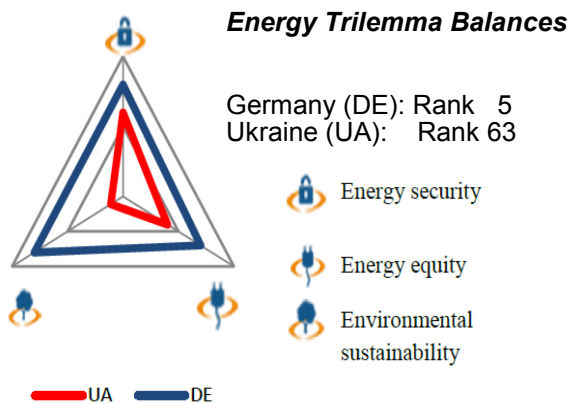
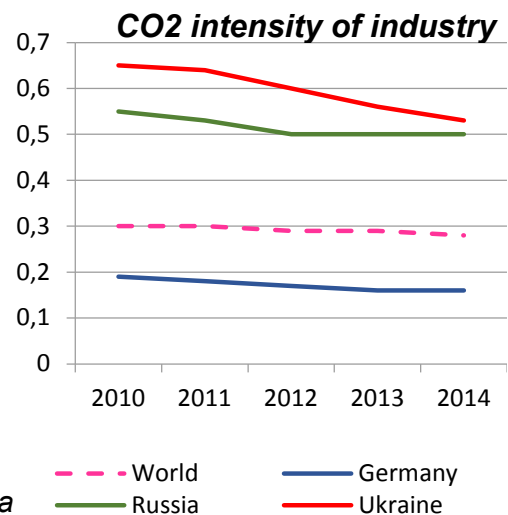
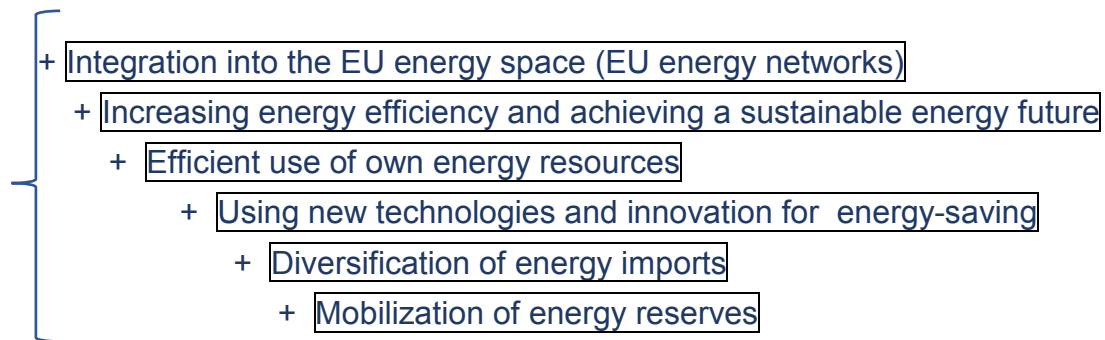

Fig.3. Comparison between the Energy Trilemma Balances of Germany and of Ukraine, 2016 (Source: calculated by [8])



As we can see, Ukraine is far behind in all indicators, especially in terms of environmental sustainability. At the same time, the review of several studies indicates that Ukrainian steel enterprises increasingly integrate energy aspects into their core business and supply chains. Such facts are based on application of some methods of strategic planning, energy sustainability considerations into economic and developmental decision-making [8].

After the signing Association Agreement with the EU, Ukraine should set itself goals that are comparable with EU objectives. The basic configuration of the new energy program of Ukraine is represented by the following formula:



The best world practices on energy management showed that countries have taken different approaches to tackling energy efficiency (See Fig. 4-5). However, today the voluntary energy certification is based predominantly on the ISO 50000 family of international standards. Among the most significant benefits for enterprises certified to ISO 50001 can be noted: increase of competitiveness due to the recognized international certificate; increase of investment attractiveness due to the reduction of risks associated with the energy demand, other positive effects [12].

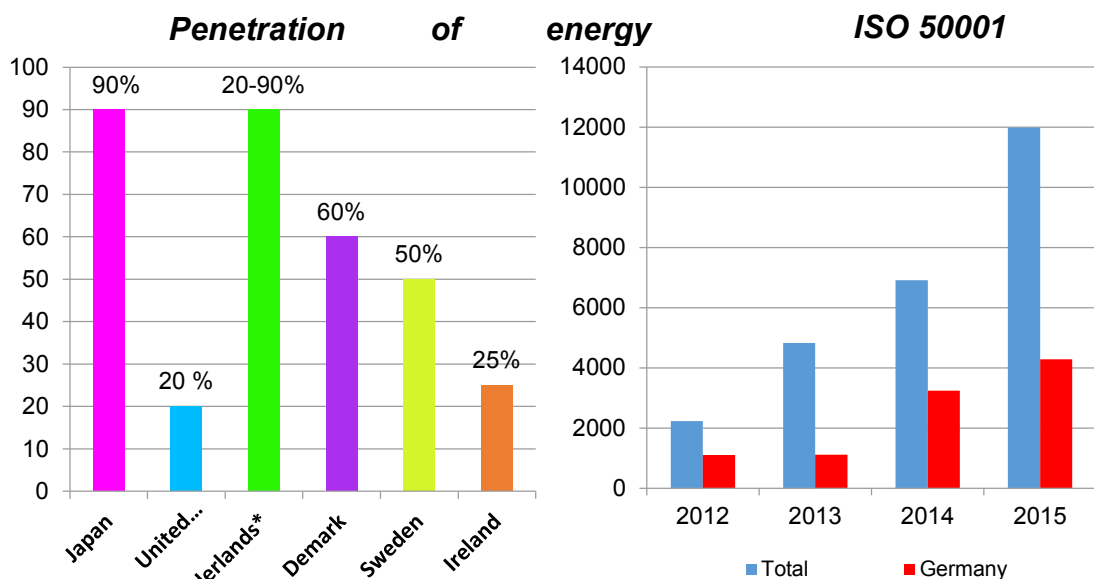

Fig. 4. Penetration of energy management standards in time and country (Source: [9])

Fig. 5. Dynamics of ISO 50001 certification (Source: calculated by [11])

In Ukraine, The EMS certified under the ISO 5001 was introduced in a five large steel holdings, such as: 'Azovstal iron and steel works', PJSC 'Khartsyzsk Tube Works', 'Ilyich Iron and Steel Works' of Mariupol (MMKI), JSC 'Zaporizhstal', 'Yenakievo Steel Plant' (EMZ).

Among the factors, that are important drivers for Ukrainian steel enterprises certified to ISO 50001, can be noted the reduction of energy consumption and the level of costs, and the reduction of energy and environmental risks with energy supply. Moreover, JSC 'Zaporizhstal' has not only improved technology in production, but also involved employees in a process by holding a special contest aimed at reducing the consumption of fuel and energy resources.

However, Ukrainian enterprises also face significant barriers on the way of implementation of ISO 50001. The most common ones are that Ukrainian top managers do not really know the principles of sustainability management and do not see the connection between the implementation of ISO 50001 and competitiveness. Among the barriers for steel enterprises certified to ISO 50001, also can be noted the lack of information and exchange of experience, and lack of government measures to stimulate the implementation of ISO 50001 [9; 12].

References

- [1] Hansmann B., Palekhov D., 2016: *Objectives and functions of voluntary sustainability standards in global value chains. In: Management for sustainable developments in transitional economies: Monograph. Dnepropetrovsk-Cottbus: NMU-BTU, PP. 14-24. ISBN 978-966-921-006-7*
(In Russian: Б. Хансманн, Д. Палехов. Задачи и функции добровольных стандартов устойчивого развития в глобальных цепочках создания стоимости // Управление устойчивым развитием в условиях переходной экономики: монография. – Днепропетровск-Коттбус: НГУ-БТУ, 2016. - С. 14-24. ISBN 978-617-7109-91-3)
- [2] Shvets V., Palekhova L., 2015: *Energy strategy of Ukraine: modern challenges. In: International workshop "Energy supply and energy efficiency", TU Azerbaijan, Baku. Cottbus: Brandenburg University of Technology Cottbus – Senftenberg, PP. 7-9. ISSN 3-9810211-8-5*
- [3] Palekhova L., 2014: *Economic instruments for integrating climate change considerations into development strategies of industrial regions in Ukraine – experience and issues. In: Implementing Adaptation Strategies by Legal, Economic and Planning Instruments on Climate Change / Environmental Protection in the European Union. Volume 4. Springer Verlag: Berlin-Heidelberg, PP. 171-180. ISBN 978-3-540-77613-0*
- [4] Pivnyak G., Shvets V., Paliekhova L., 2015: *Standards for responsible mining. In: Management for sustainable developments in transitional economies: Monograph. Dnepropetrovsk-Cottbus: NMU-BTU, PP. 18-32. ISBN 978-617-7109-91-3*
(In Russian: Пивняк Г., Швец В., Палехова Л., 2015: Стандарты ответственного горнодобывающего производства // Управление устойчивым развитием в условиях переходной экономики: монография. Днепропетровск-Коттбус: НГУ-БТУ, С. 18-32. ISBN 978-617-7109-91-3)
- [5] World Steel Association. *Steel Statistical Yearbooks 2010 to 2016. – <https://www.worldsteel.org/statistics/statistics-archive/yearbook-archive.html>*
- [6] *World steel in figures 2016. – <http://www.worldsteel.org/media-centre/press-releases/2016/World-Steel-in-Figures-2016-is-available-online.html>.*
- [7] *Specific energy consumption of steel, 2016. –<https://www.wec-indicators.enerdata.eu/world-final-energy-intensity.html#/unit-consumption-of-steel.html>.*
- [8] World Energy Council. – <https://trilemma.worldenergy.org/#!/energy-index>.

[9] Palekhova L., Simon S., 2016: *Competitive advantages through the implementation of international energy management standards*. In: *Bulletin of Prydniprov's'ka State Academy of Civil Engineering and Architecture*, № 3 (216). PP. 42-51. ISSN 2312-2676.

[10] Palekhova L., Kizilova M., 2015: *Voluntary energy-efficiency standards as an instrument of competitiveness on industrial markets*. In: *Bulletin of Tula State University*. PP. 405-412. ISBN 978-5-7679-3246-7

[11] ISO Survey-2015. – <http://www.iso.org/iso/home/standards/certification.htm>

[12] Shvets V., Palekhova L., Simon S., Palekhov D., Mammadov A., 2015: *Convergence of energy efficiency policies in the EU and countries with economies in the transfer*. In: *Social, economic and environmental problems of mining, construction and energy*. Tula State University, Tula, PP. 398-405. ISBN 978-5-7679-3246-7

Contacts:

Assoc. Prof. Dr. Tetiana Yakovenko¹, Assoc. Prof. Dr. Ludmila Palekhova²

Affiliation: SHEI "National Mining University", Dnipro, Ukraine

E-Mail: ¹ yakovenkotatiana777@gmail.com; ² palehovall@gmail.com

24. TEACHING ABOUT SUSTAINABILITY AT HIGHER EDUCATION INSTITUTIONS

Dr. Dmitry Palekhov

BTU Cottbus - Senftenberg, Department of Environmental Planning

Abstract: Sustainable development can be considered as a relatively old concept. Already in 1713 the German forester Hans Carl von Carlowitz published a book *Silvicultura oeconomica*, in which he advocated the conservation, growing and use of wood in a continuing, stable and sustained manner. This was the first documented use of the German term for sustainability or *Nachhaltigkeit*. Arguably, it was also the start of a scientific approach towards the sustainable use of natural resources, which ultimately expanded from Europe to the rest of the world. It took, however, almost 300 years until sustainable development became a global agenda.

UN Conference on Environment and Development held in Rio de Janeiro in June 1992 is widely regarded as the most important milestone in the global effort to pursue the transition towards sustainable development. Agenda 21, adopted at this Conference, mentioned and education at all levels as one of the paths to sustainability. This position also found reflection in the final document of the latest UN Conference Rio+20, i.e. *The Future we want*. Information, education and training on sustainability at all levels were referred as the key to promote sustainable consumption and production and *green economy*.

And, consequently, higher education is facing this new task of training a new generation of leaders which would be ready to face the challenges of the present and future world. As the today's students in engineering, architecture, economics and management will become tomorrow's decision-makers, whose objective will be the implementation of sustainability agenda at all possible levels.

Universities, therefore, should not only provide qualification in specific fields of knowledge, but also facilitate learning about sustainability for students in the full spectrum of non-environmental study programmes, i.e. 'green the curriculum'. At the same time, this process is not identical to environmental education. Sustainable development should be seen here as a horizontal objective that is reflected throughout all study programmes to provide transdisciplinary understanding of social, economic and environmental aspects of sustainability.

Contacts:

Dr. Dmitry Palekhov
Affiliation: BTU Cottbus - Senftenberg, Department of Environmental Planning
Tel: +49 355 69 3054
E-Mail: dmitry.palekhov@b-tu.de

25. UNTERSUCHUNGEN AN WÄRMETAUSCHERN FÜR FUßBODENHEIZUNGEN

Karel Fraňa¹, Sylvio Simon², Josef Egert³ und Tomáš Kořínek⁴

¹Technische Universität in Liberec, Fakultät für Maschinenwesen, Lehrstuhl für Energieanlagen

²Brandenburgische Technische Universität Cottbus – Senftenberg, Institut für Maschinenbau und Management

Abstrakt:

Das Ziel der Untersuchung ist die Entwicklung eines neuen Konzeptes für Wärmetauscher sowie die experimentellen und numerischen Untersuchung an den wärmeübertragenden Flächen. Für die experimentelle Untersuchung wurde eine neue Messanlage gebaut und die Untersuchungsverfahren für die thermodynamischen Tests definiert. Die Strömung mit Wärmeübergang wurde mit der Hilfe der numerischen Simulation untersucht. Die Ergebnisse wurden mit den experimentellen Ergebnissen verglichen und zeigten eine hohe Übereinstimmung. Außer den thermodynamischen Untersuchungen wurden auch Studien der Luftqualität durchgeführt. In diesem Fall geht es um eine numerische Studie zur CO₂ Verteilung im Raum. Eine niedrige erforderliche Frischluftzufuhr führt oft zu einem niedrigen Energieverbrauch.

Keywords: *strukturierte Bleche, Wärmetauscher, Strömung, Berechnung, Wärmeübertragung, Wandflächen, CO₂ Verteilung*

Einleitung

Die Energieeffizienz ist in verschiedenen Anwendungsgebieten ein wichtiger Punkt für Innovationen und technischen Fortschritt. Rund 35 Prozent des gesamten Energieverbrauchs wird in Deutschland für Gebäudebeheizung verbraucht. Der erste und einfachste Schritt zur Energieeinsparung an Gebäuden ist das Anbringen einer Gebäudedämmung. Als nächster Schritt muss die Energieeffizienz in den Heizungs- und Klimaanlage betrachten werden. Je nach Effizienz der Heizung- oder Klimaanlage können die Anlagen einen besonders großen Energieverbrauch verursachen. Dabei spielt vor allem das Alter der Geräte eine Rolle. Momentan liegt das durchschnittliche Alter von Heizgeräten in Deutschland bei 17,6 Jahren, über ein Drittel ist sogar älter als 20 Jahre.

Diese Veröffentlichung beschäftigt sich mit der numerischen und experimentellen Untersuchung des Wärmeübergangs in Heizanlagen. Die erste numerische Studie der strukturierten Bleche wurde in [1] vorgestellt. Die experimentelle Strömungsuntersuchung um die Bleche wurde in [2] präsentiert.

Ergebnisse

Abb. 1 zeigt die momentane Strömung durch den Wärmetauscher der Fußbodenheizung. Das Geschwindigkeitsfeld ist mit dem Vektor dargestellt und die Temperaturen mit der Hilfe der Kontur visualisiert. Für diese spezifischen Arbeitsbedingungen, die von der Intensivität der Einlaufluftströmung und der Konstruktion des Wärmetauschers definiert sind, ist sichtbar, dass die Luftströmung relativ günstig orientiert ist. Einzelne Rohre des Wärmetauschers wurden komplett umströmt, außer dem ersten Rohr. Abb. 1 beschreibt auch die Temperaturverteilung, wobei die blaue Farbe die Einlauflufttemperatur von 20°C darstellt. Die Luft wird bis im Durchschnitt auf 52 °C erwärmt. Die schwache Strömung und damit auch die größere Temperatur wurden in der Umgebung vom ersten Rohr gemessen. In diesem Fall ist es ratsam, die Geometrie zu verändern, um eine geeignete Umströmung um das erste Rohr zu erreichen.



Abbildung 1.: Geschwindigkeit- und Temperaturverteilung im Wärmetauscher mit CFD analysiert

Außerdem spielen die einzelnen Platten (Bleche) des Wärmetauschers eine genauso wichtige Rolle bei der Wärmeübertragung. In unseren Studien wurden unterschiedliche Blechstrukturen betrachtet [3]. Es ging um Diederichs, KMT, PWO und Hexagonal Strukturierung (siehe Abb. 2). Die ermittelten Ergebnisse wurden mit den Ergebnissen von glatten Blechen miteinander verglichen. Abb. 3. Zeigt, dass die maximalen Temperaturen gerade bei glatten Blechen und PWO Strukturen ermittelt wurden. Überraschend wurden bei der Hexagonal Struktur die maximalen Temperaturwerte zwischen einzelnen Erhebungen festgestellt. Das wird als nicht optimale Strömung interpretiert. D.h., die Strömung ist nicht intensiv genug, so dass kein ausreichender Wärmeübergang entsteht.

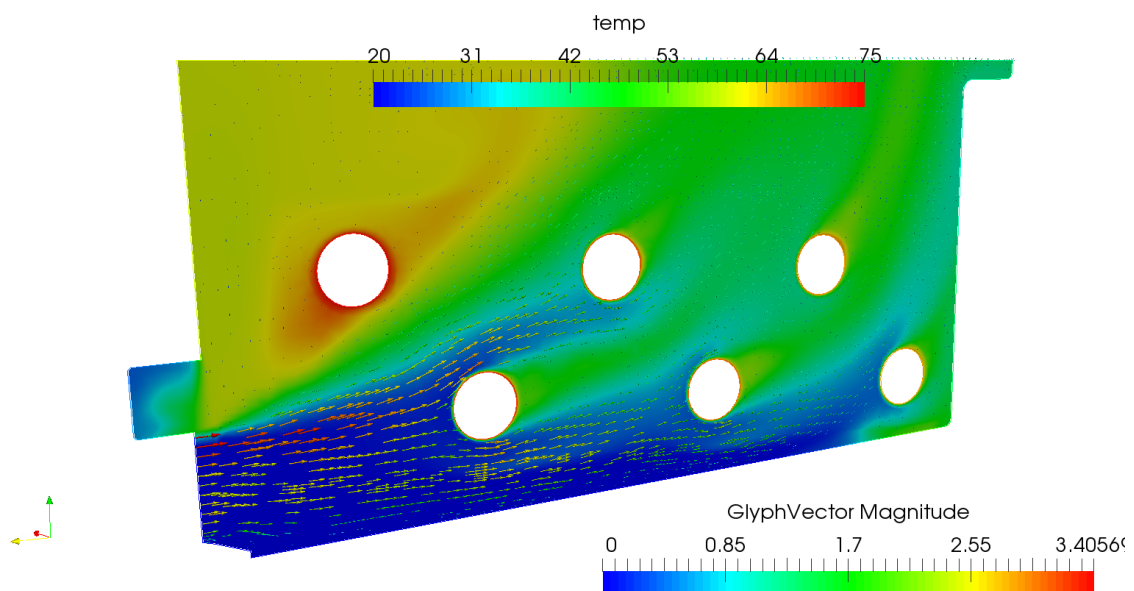
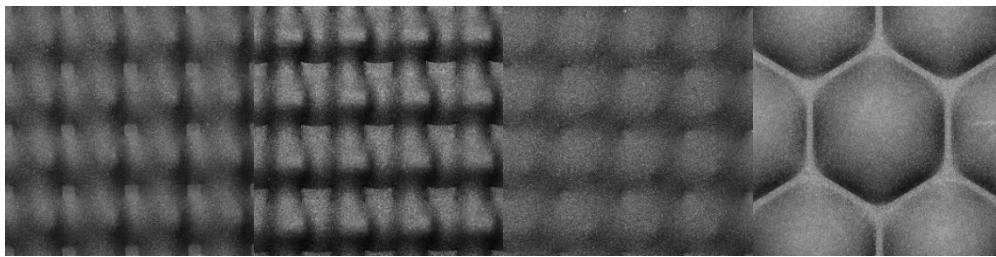

Diedrichs

KMT

PWO

Hexagonal

Abbildung 2.: Die untersuchten Blechstrukturen für experimentelle Messung

Umgekehrt wurden minimale Temperaturwerte bei der Diedrich-Struktur ermittelt. In diesem Fall ist der Wärmeübergang von den Blechoberflächen zu der umströmten Luft intensiv genug. Diese Ergebnisse werden in der Tabelle 1 zusammengefasst.

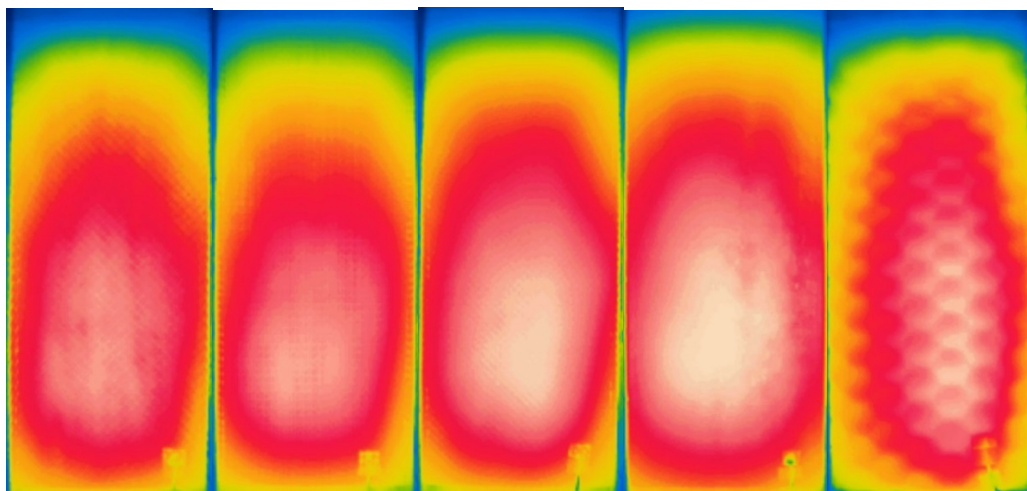

Diedrichs

KMT

PWO

glatt

Hexagonal

Abbildung 3.: Temperaturverteilung an der Blechoberfläche bei der Umströmung mit der mittleren Luftgeschwindigkeit von 10 m/s gemessen

	Diedrichs	KMT	PWO	Glatt	Hexagonal
t-durchschnittlich	73,2	74,1	82,7	87,2	73,9
t-maximal	97	99,4	109,3	112,4	104,7

Tabelle 1: Die durchschnittlichen und maximalen Werte der Temperatur an den Blechoberflächen

Abb. 4 stellt die zeitliche Entwicklung der CO₂ Verbreitung im Schnitt durch einen dreidimensionalen Raum dar. Die Größe des Rechnungsgebiets war 0,9 m x 0,85 m x 0,75 m. Das Gitter hatte 482 533 Elemente wobei es an den Eintritts- und Austrittelementen weiter verfeinert wurde. Beim Eintritt wird die Volumenkonzentration von CO₂ als 1 eingestellt. Für die numerische

Untersuchung der CO₂ Verteilung wird das klassische Modell der CFD, eine Transportgleichung für den Massetransport von CO₂, das Fick'sche Gesetz für Diffusionsvorgang und turbulente Diffusionsvorgang genutzt.



Abbildung 4.: Die CO₂ Verbreitung im Raum in der Zeit

Die in Abb. 4 dargestellten Ergebnisse beschreiben eine Entwicklung der Strömung bis zum stationären Zustand der CO₂ Konzentration. Nach der 360s Simulation gibt es keine wesentliche Veränderung der CO₂ Konzentration mehr.

Zusammenfassung

Die numerischen Simulationen wurden für die Strömungs- und Wärmeübertragungsuntersuchungen in Fußbodenheizungen angewendet. Mit Hilfe der numerischen Berechnungen wurden die optimalen Strömungsbedingungen im Zusammenhang von Wärmeübertragung und Luftqualität definiert. Ausgewählte numerische Ergebnisse wurden mit den durchgeführten Experimenten verglichen, wobei es eine sehr gute Übereinstimmung zwischen den Versuchen und den Ergebnissen der numerischen Simulation gab. Im Ergebnis der Untersuchungen zeigte sich, dass die Anwendung von strukturierten Blechen in Wärmeübertragern bzw. in Wärmetauschern deutlich zur Verbesserung des Wärmeübergangs beitragen kann.

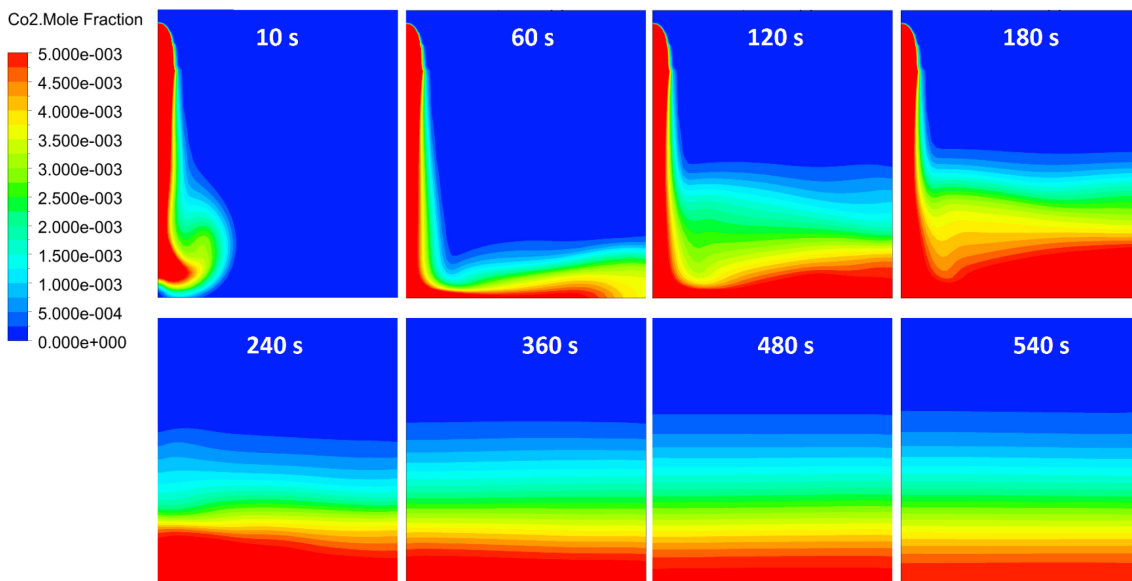
Danksagung

Diese Forschung wurde auch von studentischen Grants SGS-KEZ finanziell unterstützt. Die Untersuchungen fanden sowohl in Liberec als auch am Campus Senftenberg der brandenburgischen technischen Universität statt.

References

[1] K. Fraňa, S. Simon, "Air Flows along Perforated Metal Plates with the Heat Transfer", *World Academy of Science, Engineering and Technology, International Journal of Mechanical, Aerospace, Industrial, Mechatronic and Manufacturing Engineering*, Vol. 9, No.8, pp. 1469-1474, 2015

[2] J. Egert, K. Fraňa, S. Simon, S. Wichmann, "Heat Transfer Studies on Structured Metal Plates", *International Journal of Applied Science and Technology (IJAST)*, DOI: 10.14416/j.ijast.2016.05.002, 2016

[3] S. Simon, *Werkstoffgerechtes Konstruieren und Gestalten mit metallischen Werkstoffe*, Verlag Dissertation.de, ISBN 978-3-86624-324-8, 2008

26. MATERIALS UND MINING 4.0 – DIGITALER TAGEBAU

Autoren: Kay Kollowa, Matthias Martin (beide Actemium), Sylvio Simon

Institution: Institut für Maschinenbau und Management, Fakultät 3, BTU C-S
Actemium BEA GmbH, Fördertechnik Lausitz

Keywords: Industrie 4.0, Materials and Mining 4.0, Digitaler Tagebau, Digitalisierung, Tagebaugeräte, Tagebautechnik, Fördertechnik, Prozessvisualisierung

Die Konkretisierung und Umsetzung von Industrie 4.0 im Bereich Gewinnung und Logistik führt einer neuen Form der Prozessvisualisierung in Gewinnungs- und nachfolgenden Transportprozessen. Unter dem Thema Materials und Mining 4.0 werden verschiedene Systembetrachtungen zu einem Gesamtsystem des digitalen Tagebaus zusammengeführt, um einen größtmöglichen Nutzen zu gewinnen. Dabei ist die Prozessvisualisierung nur ein Teilbereich, Bewegungsplanungen, Routenberechnungen, Sensorüberwachungen und Fehlersuche sind weitere Möglichkeiten im digitalen Tagebau.

Der Visualisierungsprozess umfasst eine Nachbildung von Tagebaugroßgeräten in Form von 3D-Modellen. Diese 3D-Modelle sollen in Echtzeit mit Hilfe einer speziellen Prozess-Visualisierungssoftware und eingehenden Parameterwerten der speicherprogrammierbaren Steuerung animiert werden. Die jeweiligen Bewegungsabläufe entsprechen dabei denen der realen Geräte.

Die Recherchen zur Vorbereitung der Modellierung von komplexen technischen Anlagen führten zur grundsätzlichen Klärung der Frage der Modellierung. Zum einen gibt es die Möglichkeit der Nutzung bereits bestehender Geometriemodelle der Hersteller von Tagebautechnik, zum anderen kann auch eine Neumodellierung erfolgen. Auf dem Markt erhältliche CAD-Konstruktionsprogramme sollen bei kommerzieller Nutzung der 3D-Prozessvisualisierung zur Erstellung dieser Anlagen dienen. Der Aufbau der Datenstruktur von 3D-Objekten im Bereich der CAD-Konstruktion und der Computeranimation unterscheiden sich in einigen Punkten.

Beide Anwendungsgebiete stellen im Grunde unterschiedliche Anforderungen an ein 3D-Modell, wobei eine Konvertierung zwischen den verschiedenen Schnittstellen unter bestimmten Bedingungen möglich ist. Sollen vorhandene CAD-Modelle von bestehenden Projekten oder anderen Quellen genutzt werden, so ist es vorteilhaft, die Daten im nativen Dateiformat der verwendeten Konstruktionssoftware vorliegen zu haben. Bei der Verwendung von sonstigen Schnittstellen, sollte bei jedem Projekt separat geprüft werden, ob sich eine Konvertierung und Weiterverarbeitung der CAD-Daten lohnt. Oft gestaltet sich eine erneute, auf die Prozessvisualisierung zugeschnittene Konstruktion von technischen Anlagen effektiver.



Abbildung 1: Modellierter Tagebauabsetzer [i]

Sollen 3D-Modelle in Echtzeit gerendert werden, so ist ein enormer Rechenaufwand nötig, um einen flüssigen Bewegungsablauf zu erhalten. Es ist anstrengenswert, eine Animation mit 30 Bildern pro Sekunde zu erhalten. Das heißt, dass der Rechner eine dreidimensionale Szene 30-mal pro Sekunde rendern muss, um sie auf dem Computerbildschirm mit höchstmöglicher Qualität für das menschliche Auge darzustellen. Unter anderen ist die Komplexität des Modells und somit seine Anzahl der Polygone für die Rechenzeit eines gerenderten Bildes verantwortlich. Daher wurde untersucht und experimentell nachgewiesen, wo es Einsparpotential im Bereich der Konstruktionsvereinfachung am 3D-Modell gibt.



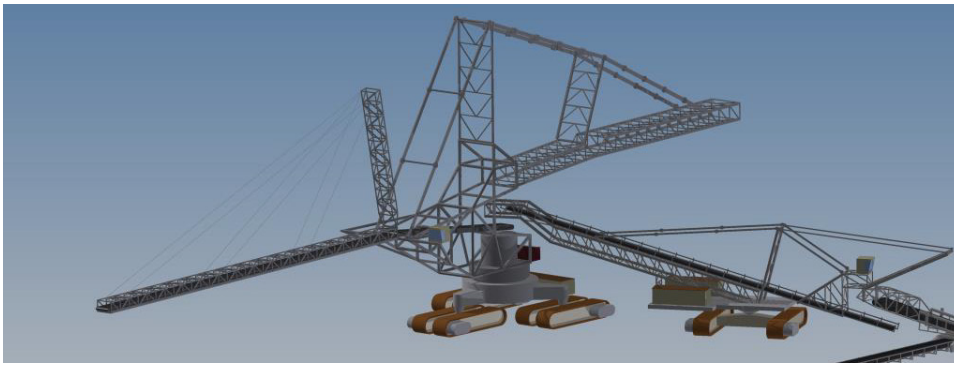

Querschnittsprofilart		Dimension	Dateigröße (DWG)
Vierkant-Rohr DIN 59410 (quadratisch) - 160x160x10		160x160x10	202 kB
Vierkant-Vollprofil DIN EN 10059 (quadratisch)		150	109 kB
L-Profil: DIN EN 10056		L150x100x12	133 kB
I-Profil: DIN 1025-5 IPE		IPE 160	165 kB
Rund-Vollprofil		150	72 kB

Abbildung 2: Vergleich von verschiedenen Querschnittsprofilen in Bezug auf die Datengröße einer Baugruppe

Da einmal fertiggestellte parametergesteuerte CAD-Daten immer wieder verwendet werden können, ist es sinnvoll, einen Baukasten für Tagebaugroßgeräte zu realisieren. Zwei Arten von Baukästen wurden erarbeitet. Zum einen ist ein Baukasten für Tagebaugroßgeräte mit Hilfe von Dialogfenstersteuerung entstanden und zum anderen eine übersichtliche Ordnerstruktur, welcher die einzelnen Baugruppen entnommen werden können. Die Baugruppen können schließlich durch die vorbereiteten Parameter bedingt

in Form und Maß angepasst werden, um sie in einer separaten Datei zusammenzufügen. Die Wahl zur Verwendung des jeweiligen Baukastens, richtet sich nach den bauartbedingten Unterschieden der Tagebaugroßgeräte und der Anzahl der benötigten 3D-Modelle.

Bei der Verwendung der erstellten 3D-Modelle in der Prozess-Visualisierungssoftware GraphworX64 ist es wichtig, die optimale Daten-Schnittstelle zu wählen. Für große Baugruppen mit einer Vertex-Anzahl von über 65.000 sollte die *.dwg-Schnittstelle benutzt werden. Sind kleinere Objekte vorhanden (unter 65.000 Vertex), so ist die *.3ds Schnittstelle vorzuziehen, da Textur-Informationen erfahrungsgemäß erhalten bleiben. Bei Verwendung der *.dwg-Schnittstelle kommt es zur Verfälschung der Textur.

Das 3D-Modell des Bandabsetzers wurde Schritt für Schritt in drei verschiedenen Detaillierungsgraden in die Software GraphworX64 implementiert und getestet. Die letzte Version, welche einen für den Anwendungsfall ausreichenden Detaillierungsgrad aufweist, besteht mittlerweile aus ca. 13.000 Einzelteilen. Die Visualisierungssoftware stößt, was die Grafikleistung betrifft, bereits an ihre Grenzen. Anhand der durchgeführten Versuche wurde nachgewiesen, dass es möglich ist, Tagebaugroßgeräte echtzeitlich in 3D zu visualisieren.



Abbildung 3: Digitaler Tagebau in der Benutzeroberfläche Editor-Modus

Die Arbeiten im Rahmen von Materials und Mining 4.0 zeigen, dass es möglich ist, einen Tagebau in die Echtzeit – Prozessvisualisierung realistisch einzubinden. Diese Möglichkeiten gestatten nun auch, Fahrmanöver von Tagebaugroßgeräten, so wie sie in Lausitzer Tagebauen verwendet werden, vorab zu simulieren, um Bewegungsfehler zu vermeiden, durch die es Anlagenstillstand oder gar Anlagenbeschädigungen kommen kann.

Vergleicht man die Entwicklung der Prozessvisualisierung im Bereich der Förder- und Gewinnungstechnik, so kann man deren Entwicklung in den letzten 15 Jahren vor allem durch die Zunahme an realistische Simulationen beschreiben. Eine anwendungsorientierte Zustandsbeschreibung der Prozessvisualisierung am Ende der 1990 Jahre befindet sich in [ii]. Stellte die Prozessvisualisierung bisher nur ein Abbild der Realität dar, sind jetzt Voraussimulationen möglich.

Video zum digitalen Tagebau: siehe QR-Code

Kontaktdaten Dr. Matthias Martin
Software Engineering - Gruppenleiter

BU Actemium Fördertechnik Spremberg



Actemium BEA GmbH
OT Schwarze Pumpe, An der Heide
03130 Spremberg / Germany

✉ matthias.martin@actemium.de

🌐 www.actemium.de

Literatur:

ⁱ Kay Kollowa, Masterarbeit BTU Cottbus- Senftenberg; Actemium BEA
Fördertechnik Lausitz, 2016

ⁱⁱ Sylvio Simon, Möglichkeiten der Materialflußoptimierung an
Betonmischanlagen; Verlag dissertation.de; ISBN 3-933342-50-3; 1999



27. ASSESSMENT METHOD OF WASTE PROCESSING SYSTEM

Marek Młyńczak, Marcin Plewa, Robert Giel

Wrocław University of Science and Technology,
Faculty of Mechanical Engineering

Abstract: Waste processing system is net of connected conveyers with points of sorting or processing. It is presented visual model of sorting plant made in FlexSim environment. In real sorting system workers work on the workstations located opposite each other on both sides of the belt. Workers collect the same fractions of waste from the running stream. Assessment method is dedicated to evaluate that kind of sorting lines and may be applied as optimization tool. It has been collected big data base covering many operational parameters. Statistical analysis allows for productivity assessment based on three measures: line efficiency, line productivity, line uniformity related to workstation workload. Each measure can achieve two values: high and low. Critical values are rated by professional judgment of experts. Overall assessment gives six states of the system and each state has its own area for improvement. Presented assessment method is easy to point out problematic area in the system and help management staff in keeping high efficiency of the sorting plant.



Figure 1. Flexim model of sorting station

Contact:

Marek Młyńczak
Wrocław University of Science and Technology, Faculty of
Mechanical Engineering
Phone: +48 71 320 38 17, email: marek.mlynczak@pwr.edu.pl

28. DIE DEUTSCHE „ENERGIEWENDE“ UND DIE FOLGEN FÜR DIE BETRIEBS- UND INSTANDHALTUNGSSTRATEGIEN VON BRAUNKOHLEKRAFTWERKEN.

1Guerrero, C., 2Töpfer, C., 3Krautz, H.J.

^{1,2,3} Chair of Power Plant Technology
BTU Cottbus-Senftenberg
Cottbus, Germany

Abstract: Angesichts der jüngsten energiepolitischen Veränderungen der Bundesregierung wird erwartet, dass der Energiemix (in Deutschland) einen erheblichen Transformationsprozess durchläuft. Erneuerbare Energien haben in diesem neuen Konzept Vorrang in der Einspeisung. Dies führt dazu, dass nur noch ein geringerer Teil der Stromverbrauchsprofile von konventionellen Kraftwerken abgedeckt wird.

Braunkohle war traditionell – als Teil der Grundlast – eine wichtige Energiequelle für die kostengünstige und sichere Stromerzeugung in Deutschland. Die zunehmende Integration von fluktuierenden Energiequellen (vor allem Photovoltaik und Windkraft) in das Energieversorgungssystem wird zunehmenden dazu beitragen, dass eine Vielzahl von betrieblichen und technischen Herausforderungen auf Betreiber von thermischen Anlagen zukommen. Beispielsweise werden die eingeplanten jährlichen Volllastbetriebsstunden von Braunkohlekraftwerken stark reduziert, des Weiteren die Start- und Abschaltvorgänge, ebenso wie häufige Wechselbelastungen zunehmen.

Diese neuen Betriebsanforderungen führen zu einer sinkenden Lebensdauer von spezifischen Komponenten. Die Materialermüdung wird durch schwankende thermische sowie mechanische Beanspruchungen hervorgerufen, die infolge steil ansteigender Lastgradienten auftreten.

Darüber hinaus wird die Flexibilisierung der Braunkohlekraftwerke auch durch den beschlossenen Atomausstieg, der im Jahre 2022 vollzogen wird, an Bedeutung gewinnen. Kraftwerksbetreiber müssen diese und andere Herausforderungen berücksichtigen und dahingehend ihre Betriebs- und Instandhaltungsstrategien optimieren.

Indem Braunkohlekraftwerke effektive und ausreichende Regelleistungsenergie bieten, um die Variabilität des Systems zu kompensieren, können sie als Übergangstechnologie maßgeblich dazu beitragen, das Stromnetz zu stabilisieren und abzusichern.

Kontakte:

E-Mail:
guerrcin@b-tu.de, Claudia.toepfer@b-tu.de, krautz@b-tu.de

29. THEORETICAL ANALYSIS OF THE INCREASE IN PRODUCTIVITY OF AUTOMATIC TRANSFER LINES.

1 Dr. Fariz Amirov, Dr. A. Mammadov

¹Azerbaijan Technical University

In article complexity of the mathematical models of automatic lines for determination of their productivity of dependence on the following parameters is considered: numbers of sites, numbers of stores, numbers of streams on each site, like the used stores, number of moderators. Some issues which are solved by the theory of productivity of automatic lines are considered at a design stage and operation.

Keywords: automatic transfer lines, productivity, parameters, stores, stream.

The researches of conducted references show that, the complexity of the mathematical models of automatic lines for determination of their productivity depends on the following parameters: numbers of sites, numbers of stores, numbers of streams on each site, like the used stores, number of moderators, etc. Classification of the automatic lines on mathematical models for determination of their productivity is provided on fig. 1. [1, 7]

To the main issues which are resolved by the theory of productivity at a design stage and operation. The choice of optimum structural configuration division of lines into sites and creation of multiline structures, determination of optimum size of the replacement between local stores and their placement to lines, definition of necessary number of moderators, the choice of a control system, etc. [2-5]

The analysis of the existing decisions on the theory of productivity of automatic lines indicates that they are generally devoted to tasks of the analysis and do not provide design process with enough qualified decisive rules.

Complexity of development of a synthesis algorithm of structural configuration of automatic lines is explained by it .

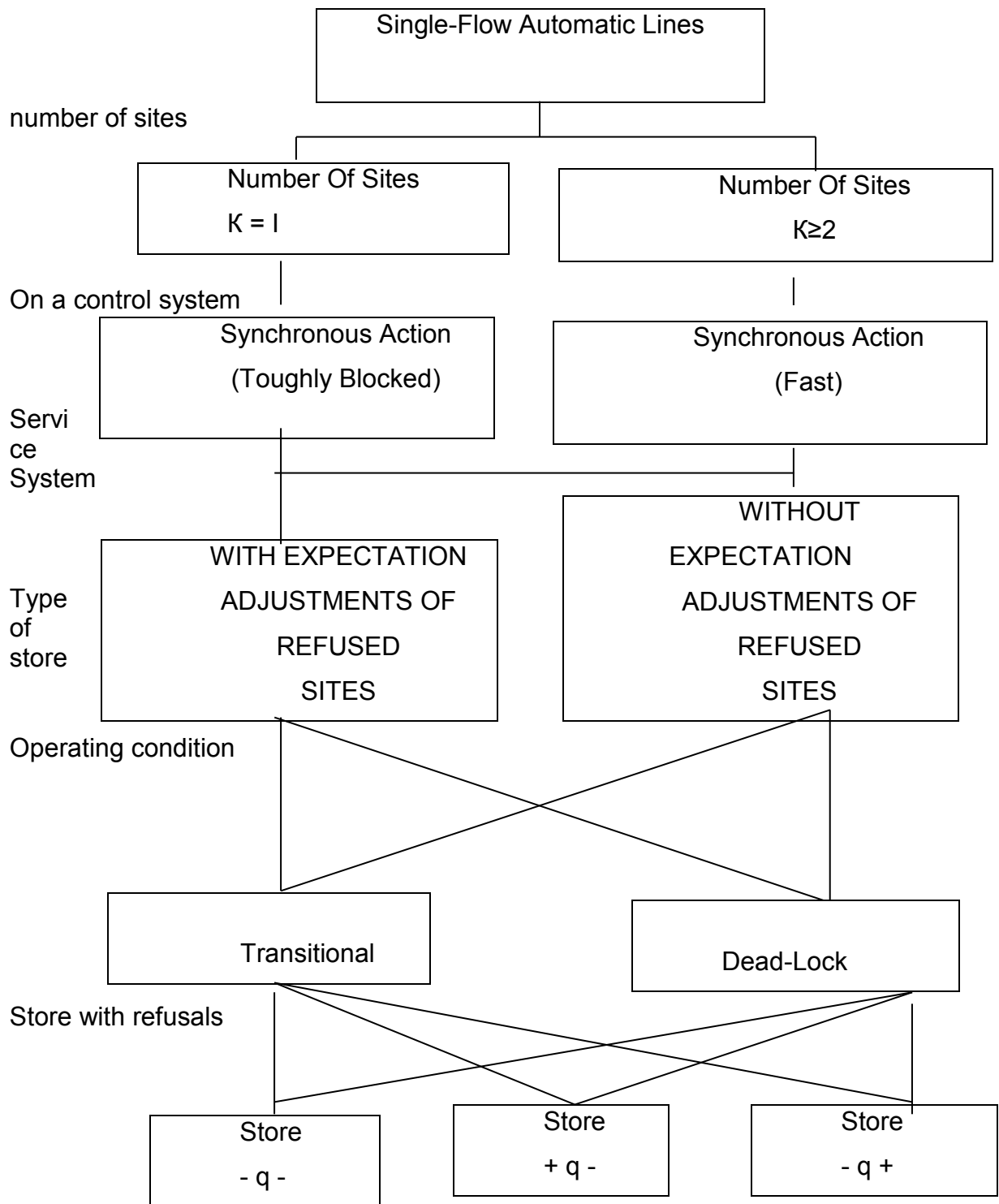

Fig. 1. Classification of single-flow automatic lines on mathematical analysis, with models, where: $(-q-)$, $(+q-)$ and $(-q+)$ are the symbols of stores which at refusal do not accept and do not give, and accept.

For the purpose of the analysis of the existing methods of calculation of the automatic lines productivity, we will consider design process on stages and we will define necessary rules for decision-making. At the same time we will mark that the technological process is set in the form of technological transitions.

1st stage. Optimization of technological process of automatic lines.

2nd stage. Determination of structural configuration of automatic lines.

Under the concept of single-flow automatic lines, such structural configurations are accepted, in which for each sector operates one flow . Under the concept of

such sector we will understand either the separately taken aggregate, or a set of toughly blocked aggregates (i.e. automatic lines with synchronous action). Under the concept of such sector, we will understand the set of the equipments between two stores or between two separators of flows. Under multithreaded structure of automatic lines, we will accept such configurations, in which at least, on one sector the number of flows are more than one.

The analysis of a mathematical model of fig. 1 shows that the decision for computation of productivity in the form of finite formulas can be received from two-district automatic lines, as the use of two stores leads to a mathematical model in private derivatives of an order more than seven, the common decision of which does not exist. [7]

To basis of the analytical decision of two-district automatic lines and generalizations of large amount of results of statistical modeling, the empirical calculation formula of productivity of automatic lines is offered, consisting of sections with the identical equipment on each section and fault-free transit stores, which has the following form: [6]

?

$$Q = \frac{q}{1 + B \left(1 + \frac{k-1}{1 + (1+B)Z_m \mu / 4q} \right)} \quad (1)$$

where: $B = \bar{t}_{BOC} / \bar{t}_P$ - specific losses of single- flow;

\bar{t}_{BOC} - average time of recovery of single refusal of a flow;

\bar{t}_P - average time of work of a flow or time between failures;

$q = 1/t_U$ - cyclic performance of one site;

$t_U = t_{BC} + t_M$ - duration of a cycle of action of single- flow;

t_M - machine (main time) action cycle.

t_{BC} - auxiliary time of a cycle of action;

Z_m - the capacity of stores (in pieces);

$\mu = 1/t_{BOC}$ - intensity of recovery of the refused flow;

k - number of sites.

Optimum number of stores determined to the subsequent formula [8]:

$$K_{opt} = \sqrt{\frac{A + N(m_1 + 1) * B_o (1 - \delta)}{(A + Nm_1)\alpha \quad 1 + B_o \delta}}$$

where A - the relation of dependence of automatic lines with synchronous action to total annual wages of the serving workers;

m_1 - the relation of annual costs on repair and servicing of automatic lines with synchronous action to total annual wages of the serving workers

α - a relative cost of the store in comparison with average cost of one machine in the line:

B_0 - total specific losses of automatic lines with synchronous action;

δ - coefficient of compensation of specific losses by the store;

N - service time of automatic lines in years.

The empirical formula of more general view for calculation of automatic lines performance is offered with complex structure and trouble-free stores with a working condition in case of refusal (-q-). This formula has the following form [9]

$$Q = q_{min} K_q \quad (3)$$

$$K_q = \min\{\eta_1; \eta_2, \dots; \eta_k\}$$

$$\eta_1 = \min\{C_{i1}; C_{i2}\}$$

$$C_{i1} \left[l + B_i (\gamma_k (B_i \cdot a_{i-1}))^{1/\sqrt{n_i}} \right]^{-1}$$

$$C_{i2} \left[l + B_i (\gamma_k (B_i \cdot a_{i-1}))^{1/\sqrt{n_i}} \right]^{-1}$$

$$q_{min} - \min\{q_1, q_2, \dots, q_k\}$$

$q_i = n_i / t_{uk}$ - cycle of action of i-th site:

B_i - specific losses of i-th site

t_{uk} - duration of cycle of action of i-th site single-flow

$\gamma_k (B_i \cdot a_i)$ - tabular value of coefficient of imposing of losses.

The generalized approximate method of calculation of productivity of automatic lines with use of the upper and lower estimates of performance, which has the following form: [10]

$$\eta = \eta_{min} + (3/5) \left((k-2)/(k-1) \right) (\eta_{max} - \eta_{min}) \quad (4)$$

where: η_{min} - the minimum availability coefficient of automatic lines.

- η_{max} the maximum availability coefficient of automatic lines.

K - number of sites of automatic lines

Methods of receipt of the lower and upper estimates of performance in work and the coefficient availability of automatic lines are introduced. This method is completely oriented to use of the calculation machines and assumes the availability of analytical decisions for calculation of performance of elementary modules from which automatic lines are packed. Therefore, when using this method, it is necessary to develop analytical decisions for the available models. The provided analysis of works on a research of performance of multiflow automatic lines shows that they cover the following class of mathematical models:

- system of automatic lines with synchronous action,

- the approximate method of calculation of productivity of multithreaded two-district automatic lines with equal cyclic productivities of sections with the transit store with a working condition in case of a failure (-q-);
 - the approximate method of calculation of productivity of multithreaded and multi-polling automatic lines without the record difference of cyclic productivities of flows with the transit store with a working condition in case of a failure (-q-).
- For the purpose of setting decided in the real operation of a problem we will consider the general task of optimum design of automatic lines.
The criterion of optimum design of automatic lines has the following form [1-7]:

$$\min = \sum_{i=1}^n 3_{AJi} \Phi / Q_i, \quad ($$

$$Q_i \geq Q_{\Pi Pi}$$

$$S \leq S^*$$

where: $3_{AJi} = f(N_i, M, S, Z, T, W)$ - the cost of current assets and the amortized assignments providing the set performance of adjustable automatic lines for i-th detail;

$Q = \psi(N, M, K, Z, T, A, B, K_{\Gamma i})$ - performance of automatic lines with specific structural configuration for i-th detail;

$N_i = \varphi_1(C_i, K_{\Gamma i})$ - number of machines in structure of adjustable automatic lines for handling i-th detail;

$M = \varphi_2(C_i, K_{\Gamma i}, N_i)$ - number of service personnel;

$K = \varphi_3(K_{\Gamma i}, N)$ - number of sites of adjustable automatic lines;

$S = \varphi_4(N, A)$ - the space occupied by adjustable automatic lines;

$Z = \varphi_5(K_{\Gamma i}, K)$ - capacity of the used stores;

T - type of transport system;

$K_{\Gamma i} = \varphi_6(C_i, N_i)$ - availability coefficient of the used machines and stores for i-th detail;

A - a management system of adjustable automatic lines;

C_i - the engineering procedure for i-th detail realized on adjustable automatic lines;

W - capacity of all aggregates of adjusted automatic lines

n - number of the made details.

Conclusions

The conducted researches show that designing of the automatic lines system for production of details of large-scale production should be based on the theory of performance and is considered very complex task.

For the purpose of statement solved in this work of a problem is considered a general task of optimum designing of automatic lines.

References

- [1] F. G. Amirov. Mechanical engineering / Solutions for theoretical task of performance of automatic transfer lines, Baku-2003, page 26.
- [2] Azarov A. S. Automation and technology of mechanical engineering. M.-L.: Mechanical engineering, 1965, page 113
- [3] Bazovsky F. I. Reliability. Theory and practice. M.: World, 1965, page 373.
- [4] Bazram R. B., Prupis L.M. Conveyors stores through passage. "Machines and tools". 1974, No. 10, page 9-14
- [5] Barlow R., Proshan F. Mathematical theory of reliability. M.: Soviet radio, 1969, page 488.
- [6] Dymshchits E. S. Development of methods of calculation of reliability of automatic transfer lines for present values of reliability of their elements. ENIMS, report on a subject, stage 3, 1964, page 336.
- [7] Sultanzade N. M. Reliability and performance of automatic machine systems. Education guidance. M.: VZMI. 1982, page 80.
- [8] Volchkevich L. I. Reliability of automatic transfer lines. M.: Mechanical engineering. 1969, page 308.
- [9] Belousov A. P., Dashchenko A. I., etc. Automation processes in mechanical engineering. M, the Higher school, 1973, page 456.
- [10] Sultanzade N. M. Optimization method of structural configuration of automatic transfer lines. Sat: "Management system machines and automatic transfer lines", M.: VZMI, 1982, page 9-13.

30. REMOTE-CONTROLLED TOOLS FOR DECONSTRUCTION TASKS

Mariusz Plak, Johannes Wilhelm, Sylvio Simon (BTU)

Institutionen: Wrocław University of Technology, Department of Machine Design and Research, Lukasiewicza 7/9, 50-371 Wrocław, Poland
Institut für Maschinenbau und Management, Fakultät 3, BTU C-S

Abstract. The paper is based on the project work concerning a remote-controlled tool – in this special case a demolition robot – to investigate its behavior during work to ensure process reliability while the task of deconstruction. Therefore, a theoretical review as well experimental testing is performed to enable to work on geometrical (CAD) and discrete (CAE) models, also to improve ergonomics of the machine by the proposal of a new tool mounting solution. Furthermore, re-involving the operator in the information flow between machine and operator by implementing a Human-Machine Interface is treated within this project.

Keywords: demolition robot, HMI (Human-Machine Interface), conceptual design, force feedback, FEM (Finite Element Method), human-controlled machines

Introduction

In times of expanding and crowding cities the importance not only of conversion and renovation of existing property, but even of new built-ups and demolition of these gains due to the fact of limited urban space. Already without regarding the demands of process reliability and efficiency during such an operation, the on first glance simple seeming task of deconstruction can become a highly complex undertaking, when it is about undocumented, abandoned property, in worst case in direct connection to neighboured buildings or within strictly limited space. It is obvious, that the automation or optimization of automated processes cannot be projected to random projects and leads to different solutions for each undertaking itself. But all these solutions have in common, that they are mainly about the relief of the workmen from the physically hard work and to ensure beside a higher efficiency of work steps and workplace safety. [1]–[4], In the recent time, a change to the usage of remote-controlled equipment is noticeable, which enables also to take on modular deconstruction tasks, for example in the demolition of skyscrapers from top to bottom and inside to outside, compared to the used pulling of old property within the seventies and eighties of the last century. One tool for this purpose is a demolition robot (Fig. 1), which is a remote-controlled, multifunctional and driveable tool, able to carry depending on its size heavy tools like hammers or crackers.



Fig. 1: Demolition Robot

The machine's ability of being remote-controlled secures in this point of view the operator from the hazardous working environment, but in fact the physically or mechanically untethered connection between operator and machine leads to a lack of information about the situation of the machine. In a consequence, even unwanted improper usage within the resonant frequency of the demolition robot can lead to breakdowns and especially also to costly downtime.

In this context, a project between Wrocław University of Technology and ARCAD Ltd. In cooperation with Brandenburg University of Technology is about to perform a numerical analysis of an existing demolition robot with a preliminary design project concerning the tool mounting and the possibility to implement a Human-Machine Interface to overcome the lack of information due to the physically untethered connection of operator and demolition robot.

Methodology

Base for the work within the project is on the one hand data provided physically by the existing robot. Measurements of components also by the use of the 3D-scanner Leica ScanStation and transferring these into a CAD-system enabled the creation of a geometrical (CAD) model. The result is shown in Fig. 2.



Fig. 2: Geometrical (CAD) model of the existing demolition robot

This base of data in form of a geometrical (CAD) model provides also the possibility to compare breakdown-related parts and components to model-different solutions on the market to identify possible reasons for breakdowns. The demand of a to this related Finite Element Analysis (FEA) expands therefore the project scope by measurements to get information about machine behaviour and set boundary conditions to declare the position and situation of the pointed assembly in calculatory space. For this sake, the authors performed measurements with a high-speed camera Phantom V12 (Fig. 3 left) and vibrometer Commtest VB7 concerning data while the states of proper and improper usage of the demolition robot. The data out of these test runs was analysed with TEMA Motion, additionally by the use of National Instruments LabVIEW, which revealed furthermore a source for reliable data (Fig. 3 right) regarding the later discussed implementation of a HMI.

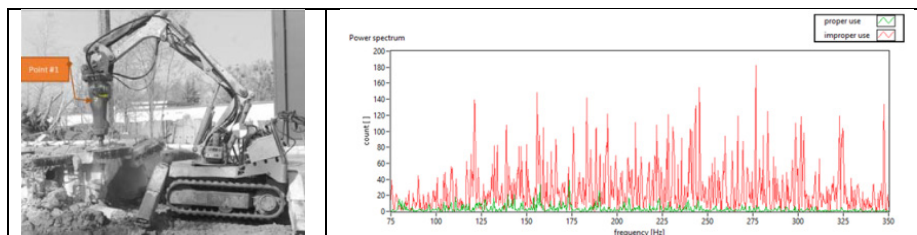

Fig. 3: Footage from high-speed camera (left) and gained frequency/power spectrum (right)

Due to several user feedbacks about failures and breakdowns of similar robots, in combination of all the mentioned input data the creation of a discrete (CAE) model in concentration to the previously mentioned tool mounting followed and was performed in NX Nastran. The calculations for static case were intended in a first step to describe stress behaviour on the mounting (Fig. 4) in order to prove the design of the machine, in this project especially the design of the mounting, which showed up with a potential to be optimized in its function as a tool mounting toward ergonomics and efficiency during tool changing.

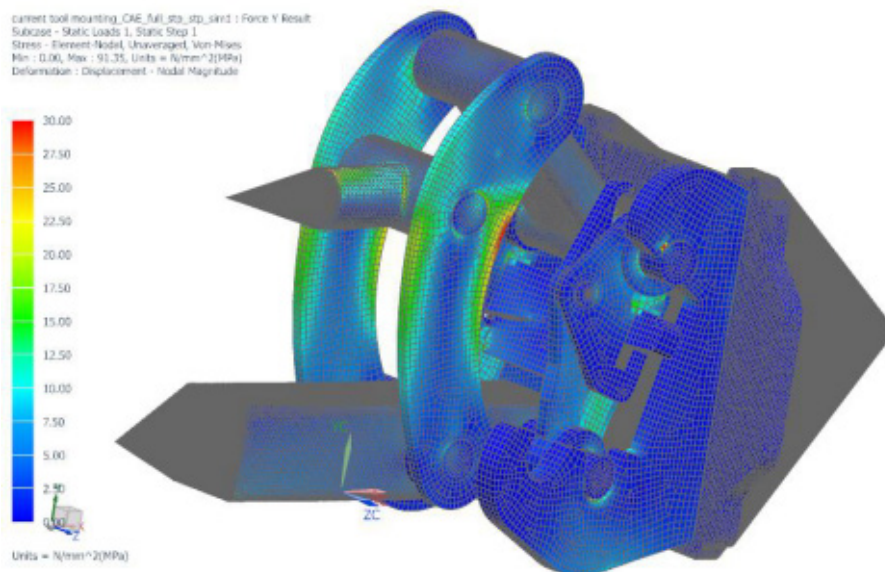

Fig. 4: Element-nodal von-Mises-stress on the original tool mounting

The results and thereby gained information helped to compare the original mounting to the solution of a new mounting and underlined additionally in this regard not only the user experiences of failures and breakdowns, but the assumption out of measurement, that suboptimal or improper usage can lead additionally to breakdowns of the normally well-dimensioned product. In the consequence, the necessity of implementing a HMI gains importance.

HMI Implementation

The existing version of an implementable HMI bases on a visual, arm-mounted matrix as status/caution/warning visual system (Fig. 5 left). [4] The here presented project concerns beside this a HMI implementation into the manipulator with pointing the view on the lack of natural information flow between machine and operator, to re-involve the operator into this information flow in a for him or her most natural way [5], [6] by the use of direct and indirect force feedback techniques.

In a more conceptual way, an also this concerning non-haptic force feedback device in form of a combination helmet (Fig. 5 right) is presented out of the project as a possible to the robot wireless tethered and – as a consequence – for the use of the robot strictly required device.

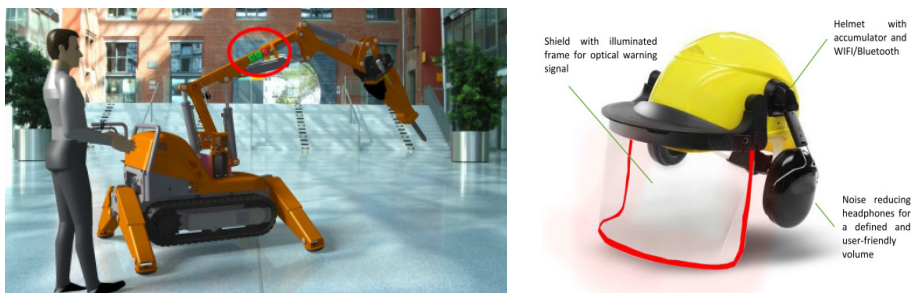

Fig. 5: Arm-mounted HMI (left) and a concept of a combination helmet as a non-haptic feedback device (right)

But it is not only intended to open the discussion about additional tasks for obligatory safety gear, especially the necessity of including this personal safety gear not only by increased ergonomics over habits back into operators will to use them and to identify as well authorized users of a specific machine is obvious due to respective injuries and incidents in cases of real life on construction sites [3], [7], [8].

Conclusion

By regarding the studies and prototypes concerning automation in the field of construction within the last 25 years it is obvious, that the will to automatize in central Europe depended mainly on the situation of manpower and workforce. Impulses from Japan and other nations in far east are always difficult to implement and only in a certain way to the regional economy of construction and the market of construction machines. Solutions, which are dedicated to the

relief of workers regarding the physically hard work are generally increasing and are continuously improved. Anyway, a universal and multifunctional construction robot for new built-ups, conversion, renovation and even demolition does not exist until yet due to the differing local situations and demands of each single case. Even similar looking tasks like the plentiful deconstruction and demolition of plattenbau and prefabricated building in the former east of Germany did not lead to a solution, because the deconstruction took always place within the direct stock of neighboured property. In the consequence, there is still a further field for studies and operation, even in the mind of Industry 4.0.

References

- [1] F. Corucci and E. Ruffaldi, "Toward Autonomous Robots for Demolitions in Unstructured Environments," *Intell. Auton. Syst.*, vol. 13, pp. 1515–1532, 2016.
- [2] S. Simon and K. Wollenick, "Automatisierung und Robotereinsatz im Bauwesen," 1994.
- [3] F. A. O. Fernandes and R. J. A. de Sousa, "Finite element analysis of helmeted oblique impacts and head injury evaluation with a commercial road helmet.," *Struct. Eng. Mech.*, vol. 48, pp. 661–679, 2013.
- [4] D. Derlukiewicz, M. Ptak, and S. KoziółEk, "Proactive failure prevention by human-machine interface in remote-controlled demolition robots," *Adv. Intell. Syst. Comput.*, vol. 445, pp. 711–720, 2016.
- [5] T. H. Massie and J. Kenneth Salisbury, "The PHANToM Haptic Interface: A Device for Probing Virtual Objects."
- [6] O. Körner, "Entwicklung eines computergesteuerten Trainingssimulators für die Koloskopie mit aktivem Force-Feedback," 2003.
- [7] F. A. O. Fernandes, R. J. S. Pascoal, and R. J. Alves de Sousa, "Modelling impact response of agglomerated cork," *Mater. Des.*, vol. 58, pp. 499–507, 2014.
- [8] D. Derlukiewicz, M. Ptak, J. Wilhelm, and K. Jakubowski, "The numerical-experimental studies of demolition machine operator work," 2016.

31. UNTERSUCHUNGEN ZUR FERTIGUNG STRUKTURIERTER KUNSTSTOFFTEILE MITTELS 3D DRUCK AUS BIOBASIERTEN MATERIALIEN

Michael Weist (BTU), Sylvio Simon (BTU), Thomas Büsse, Johannes Ganster,
Jens Balko, Ron Jacob

Institut für Maschinenbau und Management, Fakultät 3, BTU C-S
Fraunhofer IAP Potsdam, Verarbeitungstechnikum Schwarzheide

Strukturierte Feibleche werden seit etwa 2 Jahrzehnten vor allem in der Automobilindustrie als Wärmeabschirmbleche und Abgasanlagenverkleidungen eingesetzt. Weitere Anwendungen sind gestaltete Oberflächen, C – Profile für Trockenbauwände, Kuchenformen usw. Eine Strukturierung wird oft dort eingesetzt, wo ein sich anschließender Umformvorgang zu Faltenbildung führen würde. Durch die Strukturierung treten diese Falten optisch nicht übermäßig in Erscheinung. Dabei wird das besondere Leichtbaupotential dieser strukturierten Bleche meist nicht ausgenutzt. Sie weisen nämlich eine deutlich größere Biegesteifigkeit als glatte Feibleche gleicher Blechstärke auf.

Untersuchungen mit verschiedenen strukturierten Blechen zeigten, dass bei einigen Strukturen für die gleiche Durchbiegung im Biegeversuch annähernd die doppelte Kraft gegenüber glatten Blechen gleicher Ausgangsblechstärke aufgewendet werden muss. Darin liegt nun das Leichtbaupotential, sofern es keine geometrischen Einschränkungen bezüglich des Bauraumes gibt, da natürlich das strukturierte Blech zwar nicht Volumenmäßig sondern eher Einbauraummäßig mehr Bauraum beansprucht. Das strukturierte Blech kann etwa in der halben Ausgangsblechstärke gegenüber dem Glattblech ausgeführt werden.^[iii]



Abbildung 1: Durchbiegung im 3 Punkt Biegeversuch mit der KMT Struktur (oben rechts) ^[iv]

Durch die reduzierte Blechstärke verringert sich auch die Masse für das Bauteil. Ein weiterer Effekt ist, dass durch die Struktur auch der Wärmeübergang verbessert werden kann. ^[v]

Inwieweit sich diese versteifenden und wärmeleitenden Eigenschaften vollständig oder nur anteilsweise auch auf Kunststoffe übertragen lassen, ist Gegenstand der begonnenen Untersuchungen. Da thermoplastische Kunststoffe im Umformvorgang bei thermischer Unterstützung fließen können, sind sie für eine Strukturierung äußerst interessant. Gegenüber metallischen Werkstoffen sollten deutlich höhere Umformgrade und damit auch stärkere Versteifungseffekte bei Biegebeanspruchung erreicht werden können. Für die Fertigung solcher strukturierter Kunststoffproben wurde mit der Schmelzschichtung (engl. Fused Deposition Modeling *FDM*) ein Verfahren des Rapid Prototypings gewählt. Mit diesem Verfahren konnten strukturierten Blechen nachempfundene Probekörper aus dem biobasierten Kunststoff Polymilchsäure (engl. Polylactid acid *PLA*), wie sie in Abbildung 2 zu sehen sind, hergestellt werden. Erste Versuche mit diesem in der Schmelzschichtung etablierten Material deuten auf eine Erhöhung der Biegesteifigkeit um etwa 50% hin.

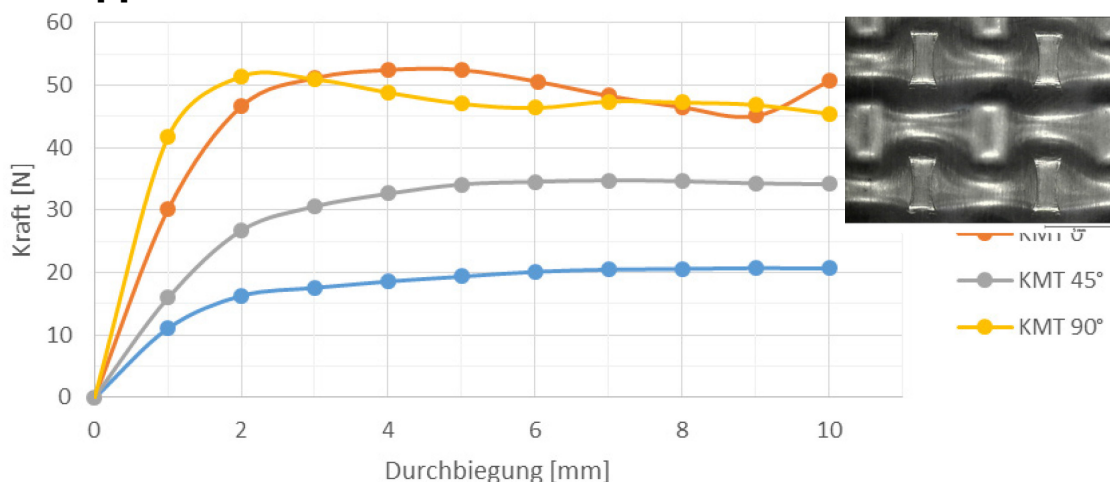

Abbildung 2: Prinzipieller Verfahrensablauf beim FDM – Verfahren (links)^[VI], gedruckte Probekörper: flaches und strukturiertes Kunststoffblech aus PLA (rechts). [Fraunhofer IAP]

Der biobasierte Kunststoff Celluloseacetat (CA) weist eine höhere Schlagzähigkeit, Biegesteifigkeit und Wärmestabilität als PLA auf. Es ist jedoch ein neues Material für das Schmelzschichtverfahren, dessen geeignete Verarbeitungsparameter zunächst bestimmt werden mussten.

Untersucht wurden die CA-Typen Setilithe 4V-35-E von Mazzuchelli 1895 SPA sowie Biograde 45.4 von Fkur. Die rheologischen und thermischen Materialeigenschaften wurden durch Ermittlung der Schmelzflussindizes sowie DSC-Messungen bestimmt. Hieraus konnte auf geeignete Extruderkopf- und Heizbetttemperaturen geschlossen werden. Für die Extrusion muss eine genügend hohe Fließfähigkeit des Materials erreicht werden. Auf die dafür nötige Extruderkopftemperatur kann mit Hilfe von Schmelzflusswerten (engl. Melt Volume Rate *MVR*) geschlossen werden. PLA wurde für die Untersuchung als Referenzmaterial verwendet. Die Schmelzflusswerte von PLA im empfohlenen Verarbeitungstemperaturbereich von 190°C bis 210°C am Extruderkopf betragen 19 – 45 cm³/10min bei einem Auflagegewicht von 5 kg. Aus den *MVR*-Messungen in Abb. 3 wurde abgeleitet, dass demnach für CA die Extruderkopftemperatur auf 210°C bis 220°C eingestellt werden muss.

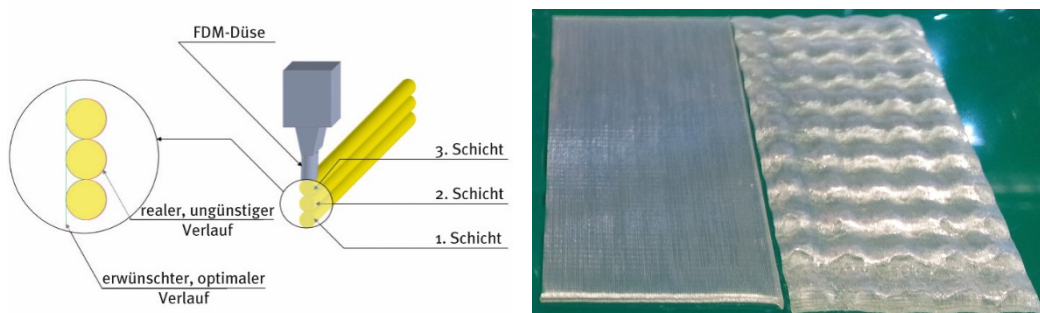

Abbildung 3 Schmelzflusswerte für die Celluloseacetat-Typen: Die geeigneten Extruderkopf-temperaturbereiche betragen für CA Setilithe 208-222°C und für CA Biograde 45.4 214-228 °C.

Um ein Ablösen des Druckkörpers vom Heizbett des Druckers zu verhindern und eine feste Verschweißung der Druckschichten zu erreichen, aber gleichzeitig die Stabilität des Materials nicht zu beeinträchtigen, ist eine Heizbetttemperatur nahe oder oberhalb der Glasübergangstemperatur T_g geeignet^[vii]. Aus den DSC-Abkühlkurven in Abbildung 4 wurden die Glasübergangstemperaturen für die CA-Typen bestimmt.

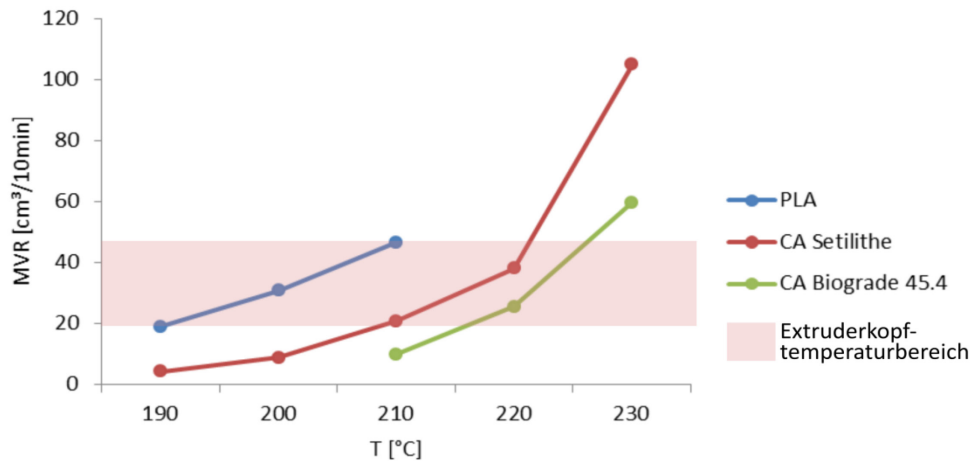

Abbildung 4: DSC Abkühlkurven bei einer Rate von 10K/min und die daraus bestimmten Glasübergangstemperaturen (Punkte) für CA Setilithe $T_g = 99^\circ\text{C}$ und CA Biograde 45.4 $T_g = 108^\circ\text{C}$.

Am Verarbeitungstechnikum Schwarzheide des Fraunhofer IAP wurden auf einem Doppelschneckenextruder aus den Granulaten Filamente mit einem Durchmesser von 2,85 mm hergestellt. Die Rundheit und Maßhaltigkeit der Filamente entsprachen den Anforderungen für einen 3D-Druck^[viii]. Testdrucke wurden auf dem Drucker X400 von German RepRap ausgeführt. Probekörper für die mechanischen Prüfungen wurden von allen Celluloseacetat-Typen auf dem X400 mit einer Heizbetttemperatur von 120°C und PET-Band als

Bettoberfläche hergestellt. Wichtig ist eine Trocknung der Filamente vor der Verarbeitung im 3D-Druck, um Bläschen im Extrudat zu vermeiden. Um die Qualität der Drucke zu beurteilen und die mechanischen Eigenschaften zu untersuchen, wurden Probekörper vom Typ1BA nach ISO 527 sowie Prüfkörper nach ISO 179 hergestellt.

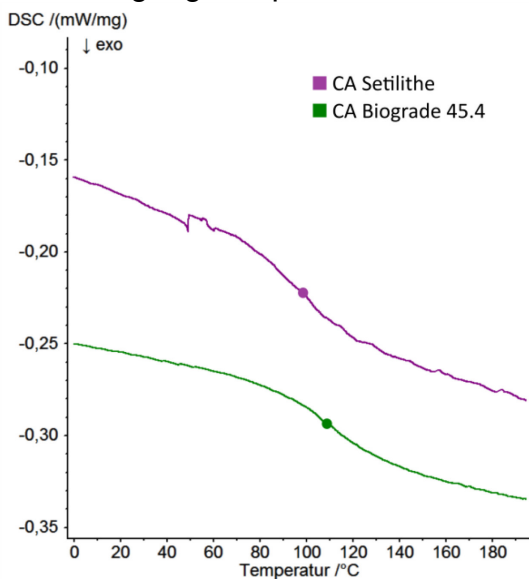

Abbildung 5: Mechanische Eigenschaften der gedruckten Prüfkörper

Die Schlagzähigkeiten der Probekörper aus CA Setilithe und CA Biograde sind um 100% bis 200% höher als die Schlagzähigkeit von PLA. Die Zugfestigkeiten der Celluloseacetate fallen um etwa 30% geringer als die Zugfestigkeiten von PLA aus. Die erhöhte Schlagzähigkeit der Celluloseacetate ergibt sich durch den Weichmacheranteil im Material, der im PLA nicht enthalten ist. Die Festigkeiten der gedruckten Celluloseacetatkörper sind trotz optisch guter Qualitäten geringer als die Festigkeiten, die im Datenblatt für Spritzgusskörper beschrieben werden. Dies ist ein in der Schmelzsichtung bekanntes Phänomen^[ix]. Ein zusätzlich beheizter Druckraum könnte die Verschweißung der Schichten, die vom temperierten Druckbett weiter entfernt sind, verbessern und somit die Festigkeit der Druckkörper weiter erhöhen.

Die Eignung von Celluloseacetat für eine Verarbeitung im Schmelzsichtverfahren konnte nachgewiesen werden. Aufgrund der enthaltenen Weichmacher werden höhere Schlagzähigkeiten als bei vergleichbaren PLA-Probekörpern erreicht. Versuche zur Herstellung strukturierter Platten aus geeignetem CA befinden sich in Vorbereitung.

Kontaktdaten:

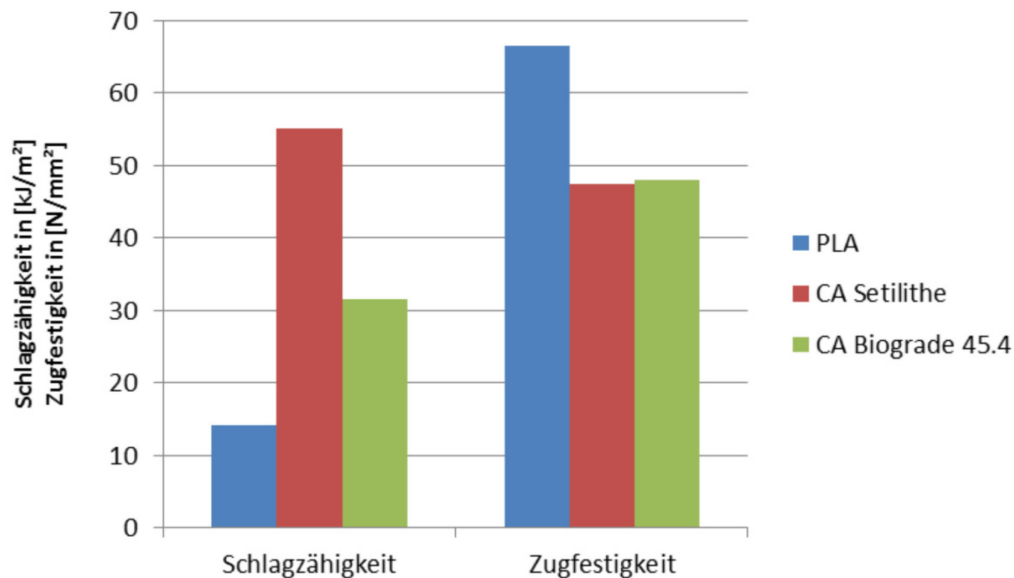
Sylvio Simon, BTU Cottbus-Senftenberg
Ron Jacob, Fraunhofer IAP Verarbeitungstechnikum Schwarzheide

Literatur:

i Sylvio Simon; Werkstoffgerechtes Konstruieren und Gestalten mit metallischen Werkstoffe, Verlag Dissertation.de, ISBN 978-3-86624-324-8, 2008

ii Sylvio Simon, Marion Hoppe, Bernd Viehweger; Strukturierte Feinbleche – Umformverhalten bei Zieh- und Hydroformverfahren; Konstruktion 5-2005, S. W7 – W9

iii Sylvio Simon, Steffen Wichmann, Josef Egert, Karel Frana; Untersuchungen zur Verbesserung der Wärmeübertragung durch die Nutzung von strukturierten Feiblechen – Experiments on Heattransfer with Structur Metal Sheets; Neseff Tagung Moskau Smolensk 2016; ISBN 978-5-91412-313-7

iv Hans B. Kief, Helmut A. Roschiwal, Karsten Schwarz; CNC-Handbuch 2015/2016, Hanser-Verlag, ISBN: 978-3-446-44090-6

v Li, L., Sun, Q., Bellehumeur, C., & Gu, P. (2002, August). Investigation of bond formation in FDM process. In *Solid Freeform Fabrication Symp., Austin, TX* (pp. 1-8)

vi Ron Jacob, Bachelorarbeit BTU Cottbus-Senftenberg, 2016

vii Walter Castro Smith, Richard W. Dean, Structural characteristics of fused deposition modeling polycarbonate material, *Polymer Testing*, Volume 32, Issue 8, December 2013, Pages 1306-1312, ISSN 0142-9418

32. ENTWICKLUNG EINES METALL – KUNSTSTOFF – VERBUNDZAHNRADES

Sylvio Simon (BTU), Robert Schiemann (BTU), Steffen Wichmann (BTU)

Institut für Maschinenbau und Management, Fakultät 3, BTU C-S

Abstract: Metall – Kunststoff – Verbundzahnrad gibt es als spritzgießtechnische Lösung für ausgewählte Nischenprodukte auf dem Markt. Die Ausführung als spritzgießtechnische Lösung sichert den Kraftschluss zwischen dem Verzahnungsring aus metallischem Werkstoff und der Kunststoffnabe. Der Kunststoff „verklebt“ mit dem Metallbauteilen. Für das Spritzgießen wird daher eine Spritzgießform benötigt, die kostenintensiv und nicht mehr in der Geometrie veränderbar ist. Der besondere Vorteil von Metall – Kunststoff – Verbundzahnradern liegt in der schwingungsdämpfenden Kunststoffnabe.



Abbildung1: Wasserstrahlgeschnittenes Metall – Kunststoff – Verbundzahnrad (BTU)

In der hier untersuchten Lösung für Einzelfertigung bzw. kleine Stückzahlen wurden die Komponenten aus Metall (Zahnring, Welle – Nabe – Einsatz) sowie die Kunststoffnabe mittel Wasserstrahlchneidverfahren mit hoher Genauigkeit ausgeschnitten und mittels Längspressverband gefügt. Für spätere Anwendungen kann der Zahnring mittels Laserstrahlchneidverfahren geschnitten werden. Prinzipiell sind alle Wärmebehandlungsverfahren wie bei Zahnradern üblich auch am Zahnring realisierbar.

Der Weg zu einer neuen Fertigungstechnologie

Zum Anfang wurden Welle-Nabe-Verbindungen gegenübergestellt, die das Fügen einzelner Komponenten ermöglichen. Zwecks unzureichender Kraftübertragung durch Reibung ist die Realisierung von reinen kraftschlüssigen Verbindungen auszuschließen. Die Kombination von kraft- und formschlüssige Verbindungen, wie Keilwellen- und Passverzahnungen, quer verpresst, führen zu einer sichereren Übertragung von Drehmomenten. In der nachfolgenden Abbildung sind Vor- und Nachteile ausgewählter Welle – Nabe – Verbindungen gegenüber gestellt. [1][2]

Welle- Nabe – Verbindungen			
Keilwellenverbindungen	Passverzahnungen	Polygonverbindungen	Querpressverbindungen
+ gleichmäßige Kraftverteilung um den Umfang	+große, stoßartige Drehmomente übertragbar	+ selbstzentrierend	+Längskräfte übertragbar
+schwellende, wechselnde Drehmomente übertragbar	+Kerbwirkung an Welle und Nabe gering	+ sehr geringe Kerbwirkung an Welle und Nabe	+sehr hohe Anforderungen an Oberflächenqualitäten
- Längskräfte zu vermeiden	- radiale Kraftkomponente durch schräge Zahnflanke, daraus resultierende Nabenaufweitung	- Herstellkosten	- unterschiedliche Wärmeausdehnungskoeffizienten zwischen Kunststoff und Stahl schwächen die Verbindung bei Temperaturänderung

Abb. 2: Übersicht über gängige Welle – Nabe – Verbindungen

Im weiteren Verlauf des Projektes stand die Untersuchung der Genauigkeit der Wasserstrahlschneidanlage „Flow Waterjet Mach 4 2513b“, mit der die einzelnen Komponenten des Verbundzahnrades herzustellen sind. Hierfür folgte die Entwicklung verschiedener, vereinfachte Proben aus S235JR, Aluminium, sowie den Kunststoffen Polypropylen und Polyamid.[3] Diese sind mit der Wasserstrahlschneidanlage hergestellt und mit einem 3D-Scanner der Firma Steinbichler digitalisiert worden.

Eine Weiterverarbeitung und Auswertung der Daten mit dem Programm „Geomagic Control“, führte zu ersten Ergebnissen der Schnittgenauigkeit, siehe Abb. 3/4, Beispiel Geometrie Zahn aus Stahl. Tb.1 zeigt eine Übersicht der Abweichungen aller Geometrien aus S235.



Abb. 3: 3D – Vergleich -und Abb. 4 2D – Vergleich von CAD-und Scandaten der Zahnradprobe aus Stahl

Abweichungen δ [mm] für Stahl					
	Da 30 mm (Welle)		Di 60 mm (Nabe)		Zahn
	Abweichung	Ist Durchmesser –	Abweichung	Ist Durchmesser –	Abweichung
2D Vergleich1	-0,077	29,923	-0,062	60,062	-0,066
2D Vergleich2	-0,062	29,938	-0,053	60,053	-0,058
2D Vergleich3	-0,068	29,932	-0,055	60,055	-0,054
Winkelfehler	0,3°		0,5°		-
δ_{Ges} \pm Messfehler	-0,069 \pm 0,005	29,931 \pm 0,005	-0,057 \pm 0,005	60,057 \pm 0,005	- 0,059 \pm 0,005

Tb. 1 Abweichungen δ aller Geometrien aus Stahl

Darüber hinaus sind Oberflächenrauheiten durch taktile Messungen aufgenommen worden. Die besten Oberflächenrauheitswerte erzielte der Werkstoff S235JR. Diese lagen bei der Zahngeometrie mit Ra 4,8 μm bzw. Rz 34,8 μm im Bereich der Qualität 10 bis 11 für Metallzahnäder. Festzuhalten ist, dass alle Werkstoffoberflächengüten für reine Querpressverbindungen 6 bis 7 mal höher ausfielen als gefordert, siehe Tb.2. Das reine Kraftschlüssige Verbindungen nicht möglich sind, wurde hiermit untermauert.

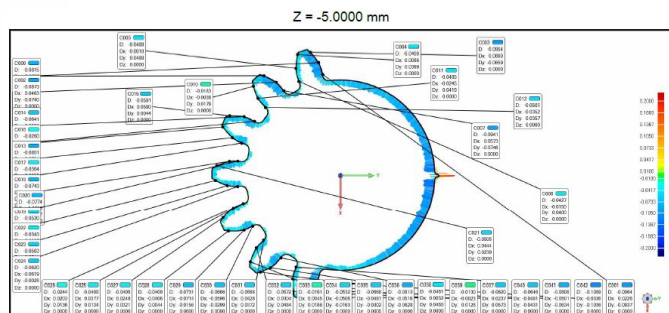
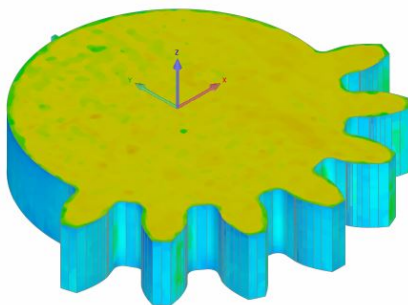
Soll – Werte für Zahnäder und Querpressverbindungen			
		Oberflächenrauheit	
		Ra [μm]	Rz [μm]
Querpress- verbindung	Da30 mm (Welle)	0,8	4,0
	Di30 mm (Nabe)	1,6	6,3
Zahnkranz	Qualität 12	-	-
	Qualität 11/ 10	6,3	40,0
	Qualität 9	1,6	14,0

Tb. 2 Soll – Werte für Zahnäder und Querpressverbindungen [1][2]

Auf Basis dieser Auswertungen wurde der Kunststoff Polyamid in Verbindung mit Stahlkomponenten positiv bewertet. Nach der vollständigen Berechnung und Konstruktion der Zahnradkomponenten mit Hilfe der Software „Autodesk Inventor“ wurden die Teile mithilfe der „Flow Waterjet Mach 4 2513b“ geschnitten, siehe Abb.5. [4][5]



Abb. 4 Schneidvorgang der Komponenten

Das Schneiden der Kunststoffteile erfolgte mit einer geänderten Schneidstrahldicke, um das Fügen mit Untermaß zwischen Stahlnabe und Kunststoffring, sowie mit Übermaß zwischen Kunststoffring und Stahlzahnkranz, zu ermöglichen. Beide vorausgewählten Formschlüssigen Welle – Nabe – Verbindungen wurden hergestellt und gefügt, siehe Abb. 6/7.[3]



Abb. 5/6 Hergestelltes Verbundzahnrad mit Keilwellenverbindung sowie Passverzahnung mit Evolventenflanken

Zukünftig sind verschiedene Verschleißtests, Rundheitsprüfung und Oberflächengütemessungen an den Zahnradern durchzuführen. Für Verschleißuntersuchungen wurde ein erster Prototyp eines Prüfstandes entwickelt, siehe Abb.8, welcher individuell modifiziert werden kann.

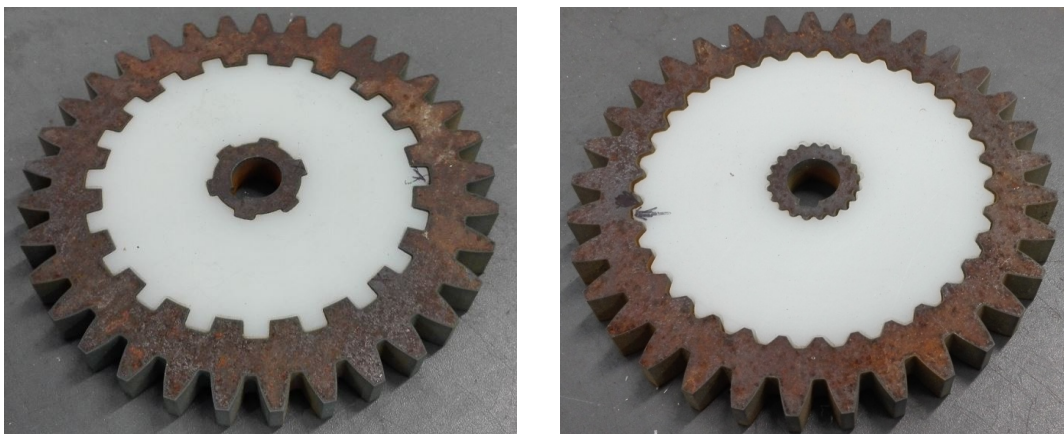

Abb. 7 Prototyp Zahnradprüfstand

Vorteile des Verbundes liegen in der Gewichtsersparnis bei gleicher Verschleißbeständigkeit durch den festen Zahnkranz. Das Gewicht sinkt bei dem nebenstehenden Zahnrad, Abb.9, durch den Kunststoffeinsatz von 1,25 Kg auf 0,74 Kg, was einer [3] Reduktion von ca. 40 % entspricht. Außerdem verminderte sich das Trägheitsmoment um ca. 23 %, was einem dynamischen Motorlauf, oder einer Leistungersparnis zu Gute kommt. Weiterhin werden kleine mechanische Stöße, die durch Anfahrvorgänge, Lastwechsel oder andere technische Faktoren entstehen, in Folge des hohen elastischen Verhaltens von Kunststoffen minimiert und Lärmemissionen gesenkt.

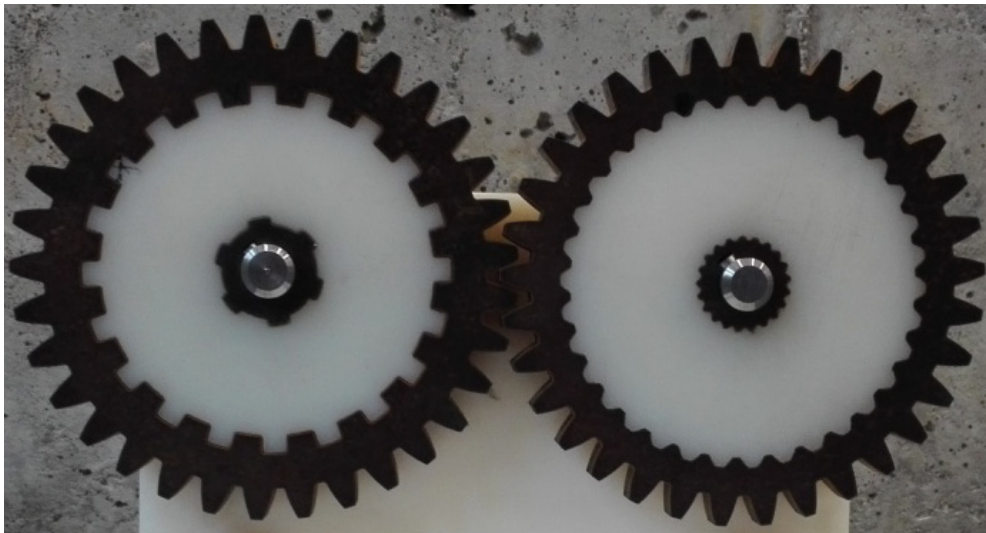

Abb. 9 Zahnradabmaße

Literaturverzeichnis

- [1] Wittel, H., Muhs, D., Jannasch, D. und Voßiek, J.. *Roloff/ Matek Maschinenelemente*, Bd. 20. Reutlingen: Vieweg+Teubner, 2011. ISBN: 978-3-8348-1454-
- [2]Schlecht,B. *Maschinenelemente 1*. Dresden: PEARSON, 2007. ISBN: 978-3-8273-7145-4.
- [3] Ehrenstein, Gottfried W. *Mit Kunststoffen konstruieren*, 2. Auflage, Hanser. ISBN: 3-446-21295-7
- [4] Krause, Werner *Plastzahnräder*, VEB Verlag Technik Berlin.
- [5] Kaufhold, *Berechnung und Konstruktion von Bauteilen mit Thermoplasten*, Leipzig, VEB Deutscher Verlag für Grundstoffindustrie, 1970.

33. UNTERSUCHUNGEN ZUR TRAGFÄHIGKEIT STRUKTURIERTER BLECHE

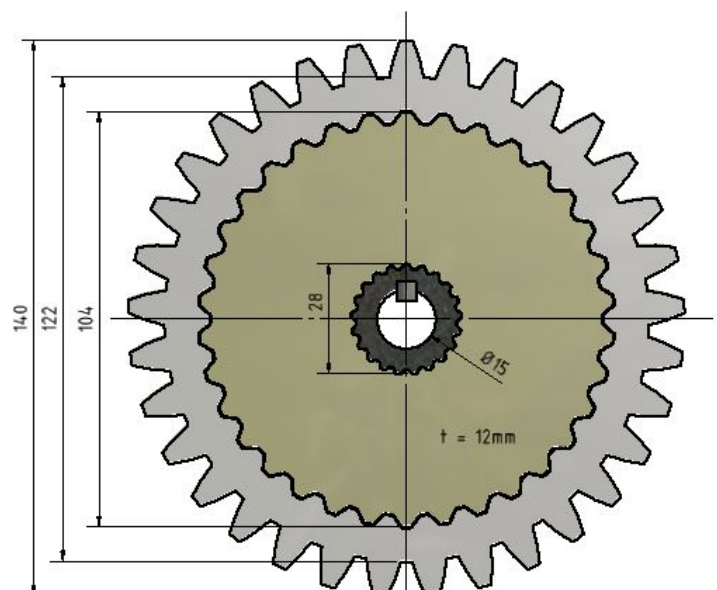
Sylvio Simon (BTU), Michael Weist (BTU)

Institut für Maschinenbau und Management, Fakultät 3, BTU C-S

Keywords: strukturierte Bleche, Biegesteifigkeit, Berechnung Leichtbau, Dehnsteifigkeit, Nebenformelemente, anisotrophe Fläche, Druckbehälter

Strukturierte Feibleche weisen eine deutlich größere Biegesteifigkeit als glatte Feibleche gleicher Blechstärke auf. Diese Eigenschaft verdanken sie den Nebenformelementen, die die Struktur bilden. „Um Biegesteifigkeit und Stabilität zu sichern oder hohe Festigkeitswerte in bevorzugten Richtungen zu erzielen, werden Flächentragwerke häufig durch linienhafte, regelmäßig angeordnete Elemente versteift oder verstärkt“ [1]. Solche Flächenkonstruktionen werden im allgemeinen als richtungsabhängig, also als anisotrop bezeichnet.[2]

In der industriellen Anwendung sind strukturierte Feibleche seit Anfang der 1990er Jahre als Wärmeabschirmbleche an Kraftfahrzeugabgasanlagen zu finden. Weitere Anwendungen gibt es im Karosseriebereich und im Bauwesen. Durch die Einbringung der Struktur wird das Ausgangsmaterial partiell umgeformt und gestreckt. Dadurch entsteht eine erhöhte Biegesteifigkeit, verbunden mit einer reduzierten Dehnsteifigkeit.

Für die weitere industrielle Nutzung ist die vollständige mathematische Beschreibung der Eigenschaften notwendig, um in Konstruktions- und Berechnungsprogrammen zeitnah das zukünftige Verhalten des modellierten Bauteils zu simulieren. Einzeluntersuchungen zum Verhalten unter einachsiger Zugbeanspruchung, zum Biegeverhalten und zum Verhalten bei Schubbeanspruchung sind notwendige Vorarbeiten. Wiedemann verweist weiter darauf, dass, wenn die Versteifungselemente regelmäßig und so eng gesetzt sind, daß über ihren Abstand etwa konstante Spannungen und Verformungen herrschen, die anisotrope Fläche als Kontinuum angesehen werden kann.



Abbildung 1: geometrische Kennwerte von strukturierten Blechen bzw. Flächenartigen Bauteilen

Die bisher industriell eingesetzten strukturierten Bleche weisen eng liegende Strukturierungselemente auf. Eine Besonderheit stellt hierbei die Beulstruktur da, deren Strukturierungselemente auch direkt aneinander liegen, jedoch eine

größere flächenmäßige Ausdehnung in Form einer Wabe haben als die anderen Strukturierungen mit Punkt-, Quadrat- oder Knochenmuster. In Bezug auf die verwendete Ausgangsblechstärke von 0,5 – 1,0 mm, Strukturhöhen bis zu 4 mm und Strukturabstände bis ca. 15 mm können bisher gefertigte Bauteile aus strukturierten Bleche mit Bauteillängen über 1000 mm im Sinne der Wiedemann'schen Definition als Kontinuum betrachtet werden.

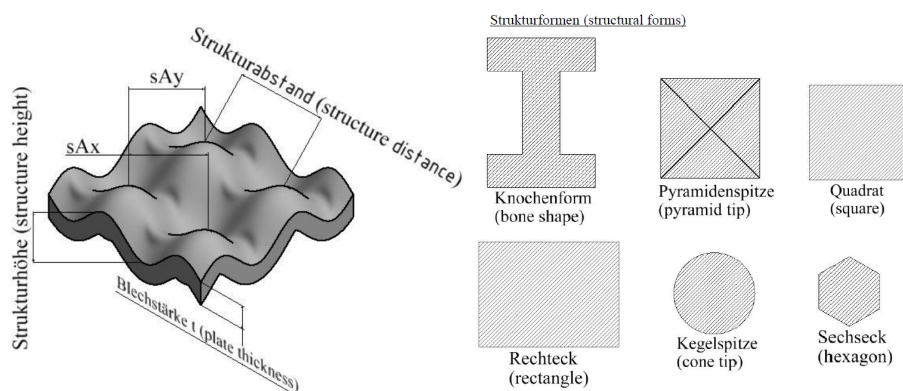

Abbildung 2: verschiedene Strukturformen (Auswahl)

Die Erhöhung der Biegesteifigkeit ist vom Strukturmuster und den geometrischen Merkmalen der Struktur wie Strukturtiefe /-höhe sowie Strukturabstand in Längs- und in Querrichtung abhängig. Bei industriell gefertigten strukturierten Blechen konnte Strukturierung eine mehrfache Biegesteifigkeit gegenüber dem glatten Ausgangsblech gleicher Blechstärke in verschiedenen Untersuchungen bereits nachgewiesen werden. [3]

Die Möglichkeit, Strukturen selbst einzubringen, gestattet Untersuchungen zu den Einflüssen der einzelnen geometrischen Parameter. Auch die Strukturordnung muss nicht zwingend beidseitig sein. Abbildung 3 zeigt eine einseitig eingebrachte Walzstruktur. Der Einfluss der Strukturhöhe konnte exemplarisch an der btu 01 Struktur ermittelt werden.

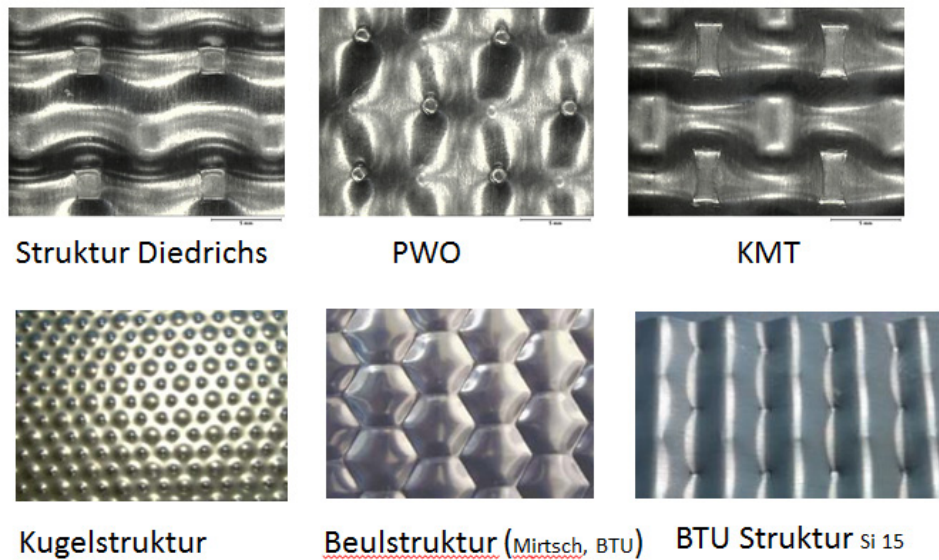

Abbildung 4: Einfluss der Strukturhöhe auf die Biegesteifigkeit.

Sieht man sich den ersten Bereich der x- Achse detaillierter an (siehe Abbildung 4), so fällt auf, dass es sowohl weniger geeignete Strukturen als auch eine Mindeststrukturhöhe je Struktur zu geben scheint, um den Effekt der höheren Biegesteifigkeit zu erreichen. Immerhin erreicht die Struktur mit der Strukturhöhe 2,8 mm bei einer Durchbiegung von 0,6 mm etwa das 3 fache an Kraft wie das glatte und das nur 2 mm strukturierte Blech.

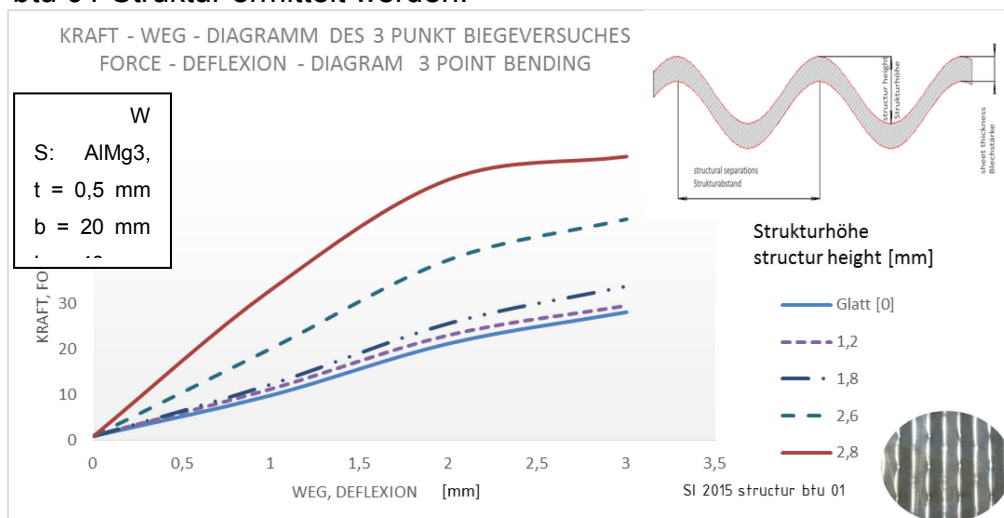

Abbildung 5: Detailbetrachtung des 3 – Punkt – Biegeversuches

Der flache Verlauf der Kurve für die Struktur 2,8 am Beginn der Beanspruchung ist mit einer minimalen Relativbewegung der Probe zu erklären. Diese doch eher stark geraffte Struktur btu 01 erreicht nicht die Biegesteifigkeiten der industriell gefertigten Strukturen. Zum Vergleich, die biegesteife Struktur KMT, aus AlMg 2,5, t = 0,5 kann gegenüber dem glatten Ausgangsblech eine etwa 4 fache größere Kraft aufnehmen.

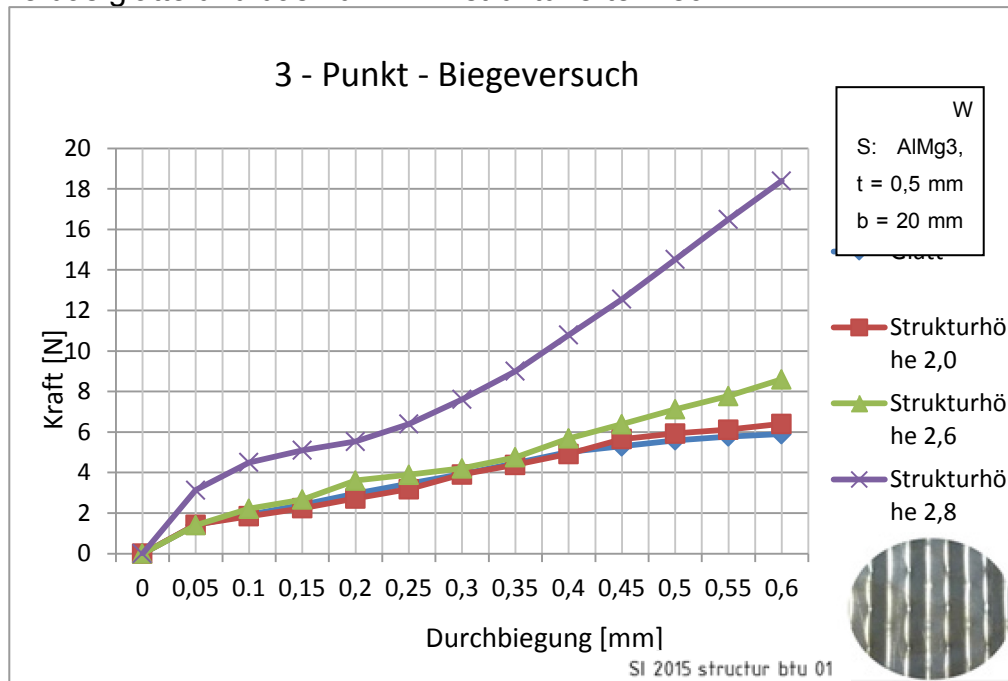

Abbildung 6: 3 Punkt Biegeversuch mit KMT Proben, bis zur Durchbiegung bei etwa 1mm ist das Materialverhalten elastisch.

Eine laseroptische Analyse von Oberflächenstrukturen zeigt, dass es eine strukturabhängige Verteilung der Flächenanteile von der Mittelebene des Bleches gibt. Diese Ergebnisse korrespondieren mit der unterschiedlichen Biegesteifigkeit der Strukturen.

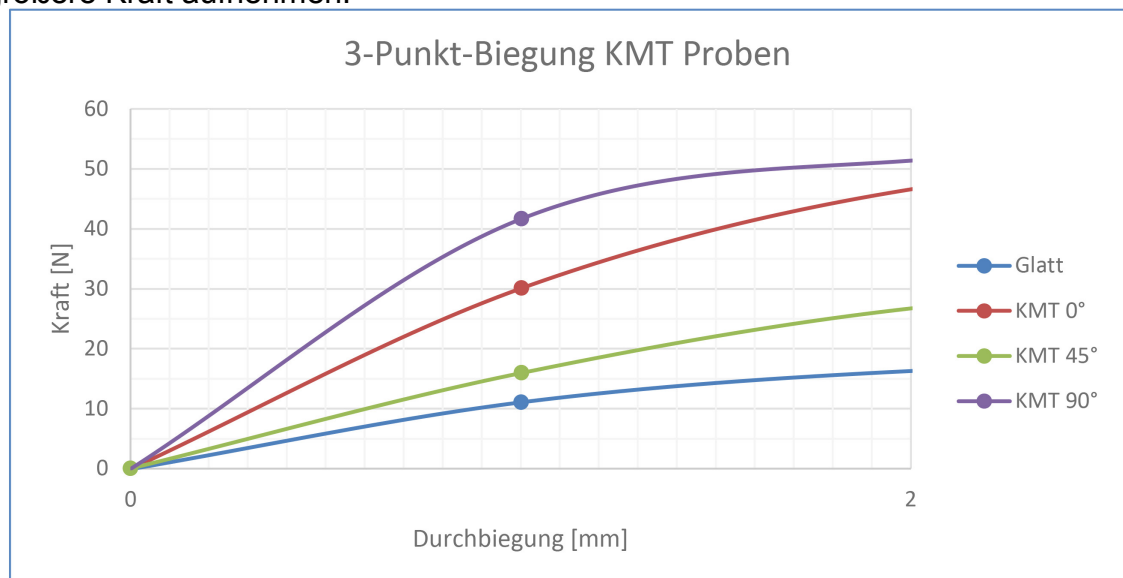

Abbildung 7: Vergleich der Traganteile verschiedener Strukturen

Für die umfassende Nachbildung der mechanischen Eigenschaften der Strukturen ist nicht nur die vollständige Geometrie mit realem Strukturverlauf und den dazugehörigen Blechdicken notwendig, sondern auch der Einfluss der Kaltverfestigung durch das Einbringen der Struktur muss berücksichtigt werden. Die Kaltverfestigung ist dabei noch flächen- und querschnittsabhängig.

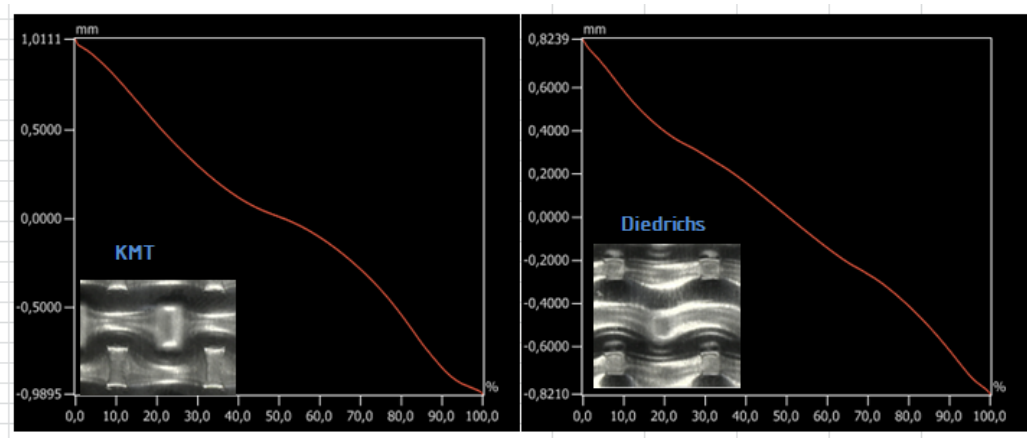

Abbildung 8: Vergleich der Flächenanteile verschiedener Strukturen,

Die erhöhte Dehnsteifigkeit der strukturierten Bleche kann konstruktiv als Sicherheitselement verwendet werden. So können Behälter für unter Druck stehende Medien bei einem nicht mehr zulässigen Druck (Überdruck) sich so verformen, dass sich die Struktur aus dem Bauteil herauszieht. Gleichzeitig vergrößert sich das Behältervolumen und der Innendruck fällt dadurch ab.

Druckbehälter aus strukturiertem Blech

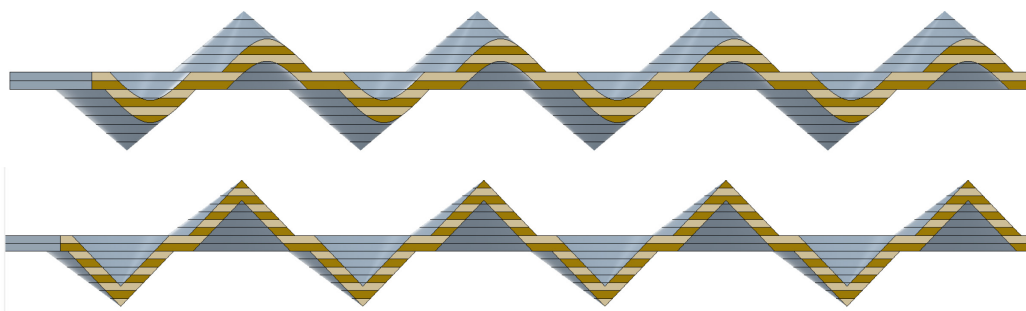

- Kleine Spannungen erzeugen bereits deutliche Dehnungen,
- Volumenzuwachs des Behälters reduziert Innendruck,
- Nicht der gesamte Behälter muss strukturiert sein.



Abbildung 9: Versuchsbehälter aus strukturiertem Blech vor und nach einem Druckversuch.[4]

Literatur:

¹ J. Wiedemann, Leichtbau, Springer-Verlag 2007, ISBN 978-3-540-33656-7

² M. Hoppe, S. Simon, B. Viehweger; Strukturierte Feinbleche – Umformverhalten bei Zieh- und Hydroformverfahren; Konstruktion 5-2005

³ S. Simon; Werkstoffgerechtes Konstruieren und Gestalten mit metallischen Werkstoffe, Verlag Dissertation.de, ISBN 978-3-86624-324-8, 2008;

⁴ F. Otremba, S. Simon; A NEW DESIGN OF HAZMAT TANKS; Tagungsbeitrag, IMECE 2016

34. ENERGIEEFFIZIENZ BEI ANTRIEBS- UND LOGISTIKLÖSUNGEN

Christin Faulstich (BTU), Jan Magister (BTU), Sylvio Simon (BTU)

Institut für Maschinenbau und Management, Fakultät 3, BTU C-S

Keywords: Energieeffizienz, Energieverbrauch, industrielle Fertigung, Pneumatische Anlage, Pneumatische Förderung, Druckluft, Druckluftherzeugung.

Energieeffizienz in der Fertigung umfasst nicht nur die Betrachtung des reinen Energieverbrauches während des direkten Herstellungsprozesses sondern auch Logistik- und Lagerprozesse. Kief definiert Energieeffizienz wie folgt: Unter Energieeffizienz versteht man den Energieverbrauch

- pro Anzahl der produzierten Werkstücke
- während der Betriebszeit der Maschine
- während der Leerlaufzeit (Stand-by) der Maschine [x]

Mit der Einführung der ISO 50001 zu Energiemanagementsystemen soll zumindest der spezifische Energieverbrauch nicht mehr wachsen. Die Einsparpotentiale ergeben sich aus dem Jahresenergieverbrauch.



Abbildung 2: Jahresenergieverbrauch der Einzelkomponenten einer CNC – Maschine [x]



Abbildung 3: Energieverbrauch eines Bearbeitungszentrums [x]

Mit zunehmend komplexeren Maschinen steigt auch der Energieverbrauch im Bereich der Druckluft, die für Steuerungs- und Handlingsfunktionen genutzt werden kann. Das gesamte Einsparpotential wird deutlich, wenn man sich den Gesamtenergieverbrauch in Deutschland über einen längeren Zeitraum ansieht.

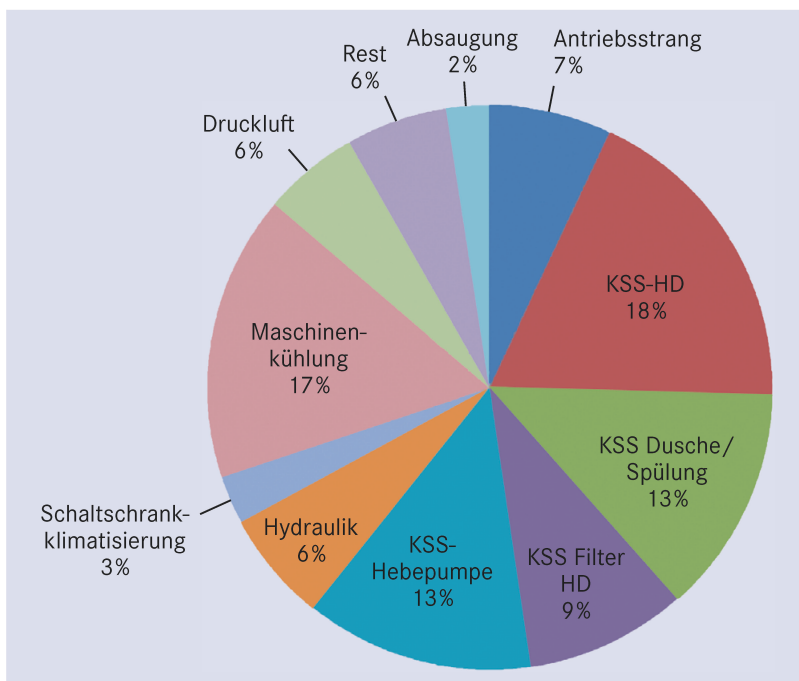
Entwicklung des Endenergieverbrauchs nach Sektoren

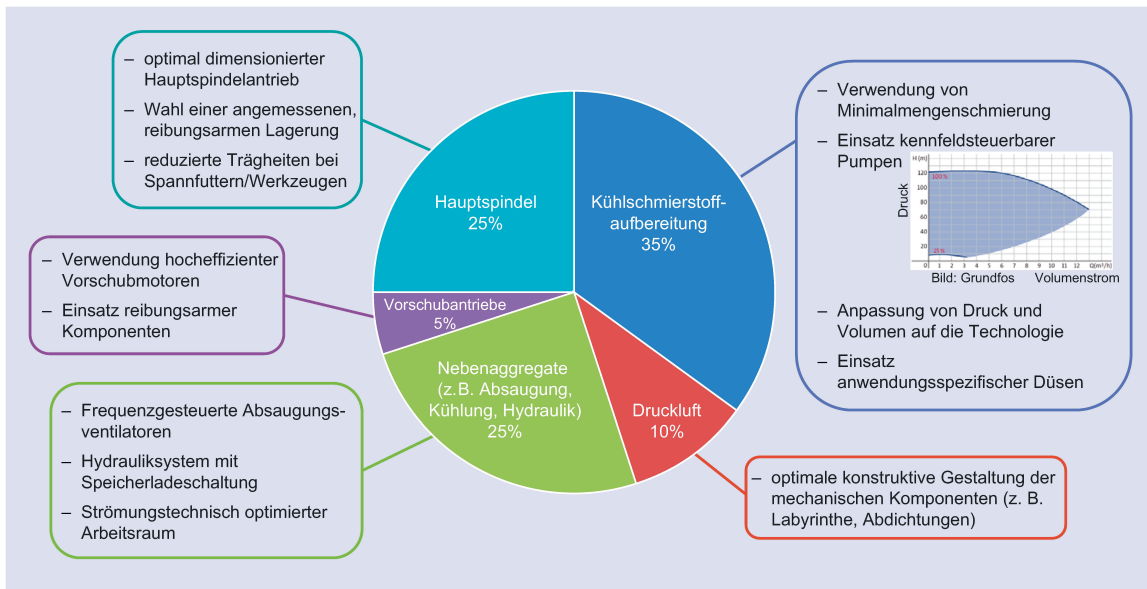
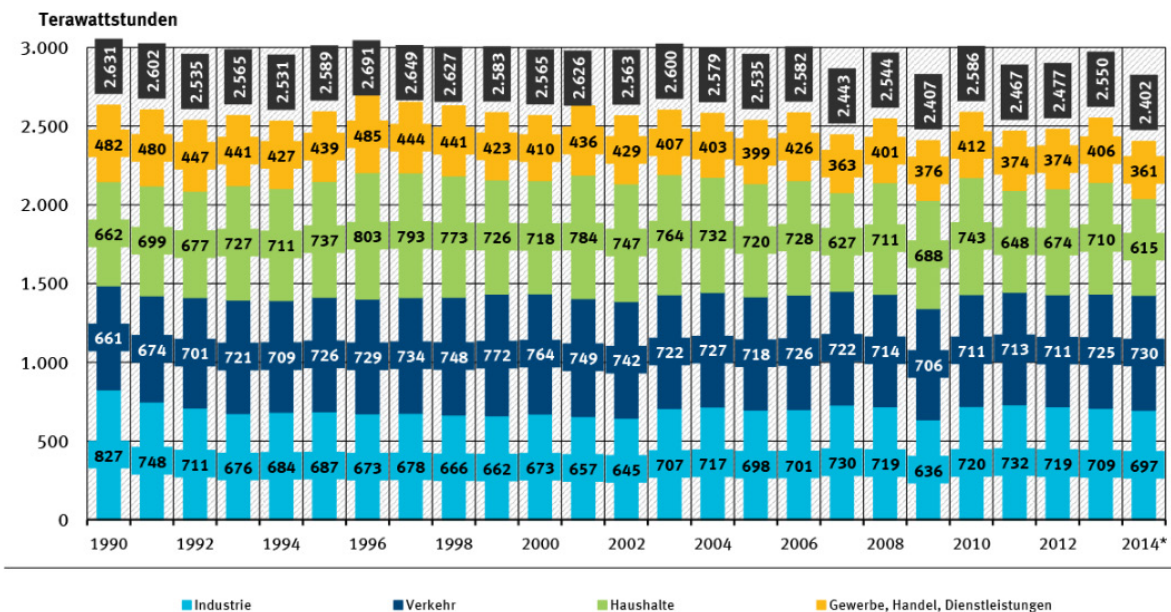

* Vorläufige Angaben

Quelle: Arbeitsgemeinschaft Energiebilanzen: Auswertungstabellen zur Energiebilanz der Bundesrepublik Deutschland 1990 bis 2014, Stand 08/2015

Abbildung 16: Entwicklung des Endenergieverbrauchs nach Sektoren

Der Gesamtenergieverbrauch in Deutschland über die letzten 25 Jahre schwankt zwischen ca. 2,4 bis ca. 2,7 TW, wobei jedoch der Industrieverbrauch seit 2011 um ca. 5% zurückgegangen ist. Der Anteil für Verkehr hat sich jedoch

erhöht. Betrachtet man nun den Verkehr als ein Element der Logistik, dann sind Effizienzbetrachtungen für Logistikprozesse nicht zu vernachlässigen. Ein ganz bedeutender Logistikprozess ist dabei die Pneumatische Förderung.

Aufgrund des Trägermediums Druckluft ist die Pneumatische Förderung eine kostenintensive Variante um Schüttgüter von A nach B zu transportieren. Vereinfacht kann gesagt werden, dass fast die gesamte elektrische Energie zur Erzeugung der Druckluft in Wärmeenergie umgewandelt wird. Durch die Verwendung von inerten Gasen bei der Förderung von explosiven Produkten vervielfachen sich diese Kosten nochmal. Dennoch ist diese Art der Förderung z.B. in der chemischen Industrie beliebt, da man hiermit auch umweltgefährdende Produkte sicher unter Abgrenzung zur Umgebung transportieren kann.



Abbildung 17: Energiefluss an einer Druckluftanlage [xi]

Eine verbreitete Möglichkeit zur Verbesserung der Energiebilanz ist die Nutzung der Abwärme für Heizzwecke. Dies ist zumindest im Winter förderlich, da die Nutzung für Warmwasserbereitung meist nur einen geringen Anteil der zur Verfügung stehenden Wärmemenge benötigt. Zu berücksichtigen ist hierbei weiterhin das benötigte Temperaturniveau, welches teilweise nur aufwendig erreicht werden kann.

Ein sinnvoller Ansatz ist es, den Druckluftbedarf durch Optimierungen in der Förderung zu minimieren. Eine Möglichkeit ist in der Druckförderung die Erzeugung einer Pfropfenförderung statt der oft verwendeten Flugförderung.

Hierzu können an der Versuchsanlage im Institut für Maschinenbau und Management durch verschiedene Einstellungen (u.a. Volumenstrom, Drehzahl der Zellenradschleuse) Parameter optimiert werden.

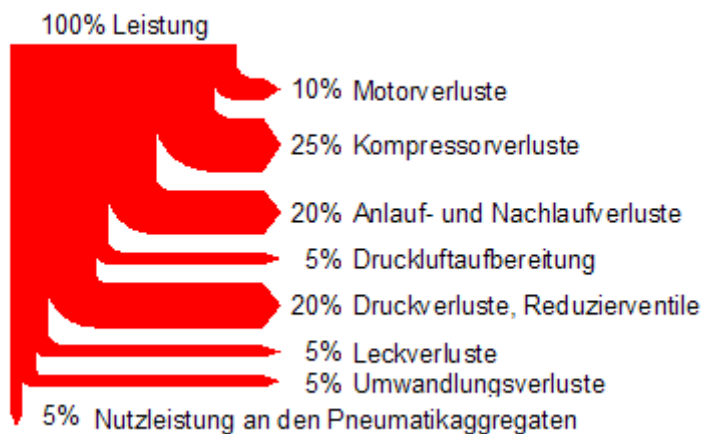

Abbildung 18: Versuchsanlage für Pneumatische Förderung am Institut für Maschinenbau und Management

Bei Pfpfenförderung wird durchschnittlich nur $1/3$ der Elektroenergie gegenüber der Flugförderung benötigt. Dies bezeichnet aber nur einen Teil der möglichen Einsparungen. Hier sind ohne Anspruch auf Vollständigkeit noch zu nennen:

- Verminderung von Abrieb / Verschleiß an Produkt und Anlagentechnik
- geringerer Raumbedarf durch kleinere Drucklufizerzeuger
- geringere Druckkesselgröße
- TÜV Prüfung nach BetrSichV von Anlage, Kessel und Ölabscheider wird kostengünstiger
- teilweise Übernahme von Wartung und Prüfung durch befähigte Personen gem. TRBS 1203 und BetrSichV Anhang 2 Abschnitt 4
- kostengünstigere Kompressorenwartung durch weniger Verbrauchsstoffe
- weniger Volumenstrom bedeutet auch weniger Rückstände im Filter und in der Abreinigung



*Abbildung 49: verschmutzter Anlagenfilter der Versuchsanlage
(Nettomaterialkosten ca. 300 Euro)*

Abschließend kann gesagt werden, dass mit der im Institut vorhandenen Versuchsanlage unterschiedlichste Schüttgüter auf ihre Eignung zur Pneumatischen Förderung untersucht und die Förderparameter je nach Vorgabe zur Optimierung des Energiebedarfes angepasst werden können. Aus Erfahrung muss hier beachtet werden, dass sich jedes Produkt unterschiedlich verhält, selbst bei gleichen Werten auf dem Sicherheitsdatenblatt.

Literatur:

x Hans B. Kief, Helmut A. Roschiwal, Karsten Schwarz; CNC-Handbuch 2015/2016, Hanser- Verlag ISBN: 978-3-446-44090-6

xi Website: <http://www.energie.ch/themen/industrie/druckluft/>

35. AKTUELLE UNTERSUCHUNGEN AN TRAGROLLEN

Stephan Henschler (BTU), Thomas Rieder (BTU), Robert Schneider (BTU), Jan Magister (BTU), Sylvio Simon (BTU)

Institut für Maschinenbau und Management, Fakultät 3, BTU C-S

1. Einleitung

Die Minderung der Geräuschemission von Hochleistungsgurtt Förderanlagen in Tagebauen stellt in Verbindung mit höheren Anforderungen des Umweltschutzes und der Akzeptanz in der Bevölkerung ein Problem dar. Zum einen gilt es Mensch und Umwelt vor Lärm zu schützen und zum anderen ist es für den Betreiber schwierig, die gesetzlichen Auflagen für den Betrieb solcher Anlagen zu erfüllen. Untersuchungen haben gezeigt, dass Tragrollen die Hauptschallquellen dieser Gurtt Förderanlagen sind. Im Rahmen einer Baugruppenprüfung werden in Kooperation mit der Lausitz Energie Bergbau AG (LEAG) akustische und mechanische Kenngrößen von Tragrollen auf einem Prüfstand (TPS) an der Brandenburgischen Technischen Universität Cottbus-Senftenberg untersucht (Abb.1).



Abbildung 1: Tragrollenprüfstand (TPS)

Bestandteile dieser Untersuchungen sind:

- Hochfahrprüfläufe – Dabei wird eine Tragrolle unter Prüflast auf eine Umfangsgeschwindigkeit von 10 m/s beschleunigt und der Schalldruckpegel aufgezeichnet. Dies ermöglicht die Berechnung der Schallemission in Abhängigkeit von der Umfangsgeschwindigkeit.
- Ermittlung des Abklingverhaltens – Durch Anschlagversuche wird das Eigenschwingverhalten einer Tragrolle erfasst.

157 *Abbildung 5: Wendeschneidplatte mit Eckenradius r*

- Erfassung der Tragrollengeometrie – Die präzise Beschreibung der Geometrie des Tragrollenmantels ermöglicht Rückschlüsse auf mögliche Anregungsursachen.

Die ermittelten Kenndaten erlauben eine quantitative Bewertung der akustischen Wirkung von Tragrollen und ermöglichen die Ableitung von Vorgaben für den Einsatz in Gurtförderanlagen. Basierend auf den Erkenntnissen umfangreicher Tragrollenprüfungen und Untersuchungen wurden die Lieferanforderungen der LEAG an Tragrollen um neue Parameter erweitert und präzisiert. Somit wird eine gezielte Beschaffung von geräuscharmen Tragrollen ermöglicht.

2. Untersuchungsprogramm

2.1. Hochfahrprüfläufe

Um die Schalleistung in Abhängigkeit von der Gurtgeschwindigkeit anzugeben, werden am Tragrollenprüfstand Hochfahrversuche mit Tragrollen durchgeführt. Die Tragrolle wird dafür auf dem Prüfstand eingespannt und mit einer definierten Last auf die Antriebswalze gedrückt. Anschließend wird die Tragrolle auf eine Umfangsgeschwindigkeit von bis zu 10 m/s beschleunigt und der dabei entstehende Schalldruck von drei Messmikrofonen aufgezeichnet. Für die Ermittlung der Schalleistung aus den aufgenommenen Schalldrücken wird ein Hüllflächenverfahren in Anlehnung an die DIN EN ISO 3744:2011 eingesetzt. Dafür wurde der Prüfraum mit Schallabsorptionsmaterial ausgekleidet und ein geeignetes Hüllflächenmodell ausgewählt (Abb.2).



Abbildung 2: Hüllflächenmodell Halbkugel über reflektierender Oberfläche mit den Positionen der Schalldruckmikrofone zur Bestimmung der Schalleistung bei Ablauf der Tragrolle [1]

Die Umfangsgeschwindigkeit wird über die, durch Magnetkontakte aufgenommene Drehzahl ermittelt und ermöglicht somit die Darstellung der Schallintensität in Abhängigkeit zur jeweiligen Umfangsgeschwindigkeit (Abb. 3)

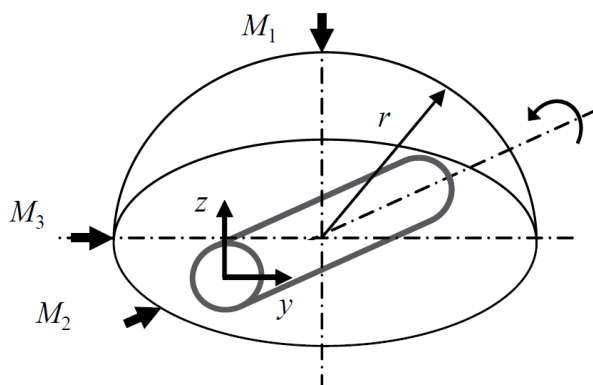

Abbildung 3: Schematische Darstellung von Schalleistungspegeln eines Tragrollentyps (A194x750-6310-G2-18) in Abhängigkeit von der Umfangsgeschwindigkeit

Die Hochfahrversuche einzelner Rollen mit diesem Verfahren bei Prüfung einer ganzen Charge ermöglichen Aussagen zum akustischen Verhalten in der Gurtförderanlage. [1]

2.2. Anschlagversuche

Ein weiterer Bestandteil dieser Untersuchungen ist ein Anschlagversuch zur Erfassung akustischer Kenngrößen. Mit diesem kann das Eigenschwingverhalten einer Tragrolle aufgenommen werden. Die dabei ermittelten Frequenzspektren des Schalldruckpegels deuten darauf hin, dass der Stahlmantel wesentlich die Geräuschemission einer Tragrolle beeinflusst (Abb. 4).

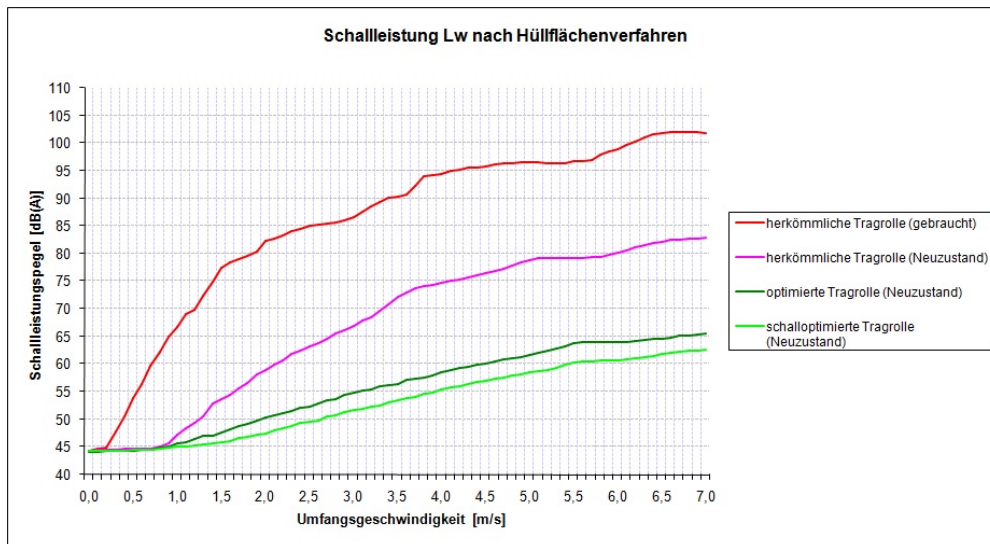

Abbildung 4: Frequenzspektrum des an drei verteilten Mikrofonen gemittelten Schalldruckpegels nach Anschlag einer Stahlmanteltragrolle (Durchmesser 194 mm, Länge 750 mm)

Weiterhin können die Dämpfungseigenschaften untersucht werden. Dies erfolgt durch die Ermittlung des Abklingverhaltens. Dafür wird die Abnahme des Schalldruckpegels in Abhängigkeit von der Zeit nach einem definierten Anschlag ausgewertet. Das Dämpfungsverhalten einer Tragrolle ist von ihrer konstruktiven Gestaltung und den eingesetzten Werkstoffen abhängig. So zeigen klassische Tragrollenkonstruktionen mit Stahlrohrmantel ein Abklingverhalten, das dem einer Glocke entspricht. Durch konstruktive Änderungen des Tragrollenmantels oder durch den Einbau von zusätzlichen

Dämpfungselementen können deutlich bessere Abklingwerte erreicht werden (Abb. 5).

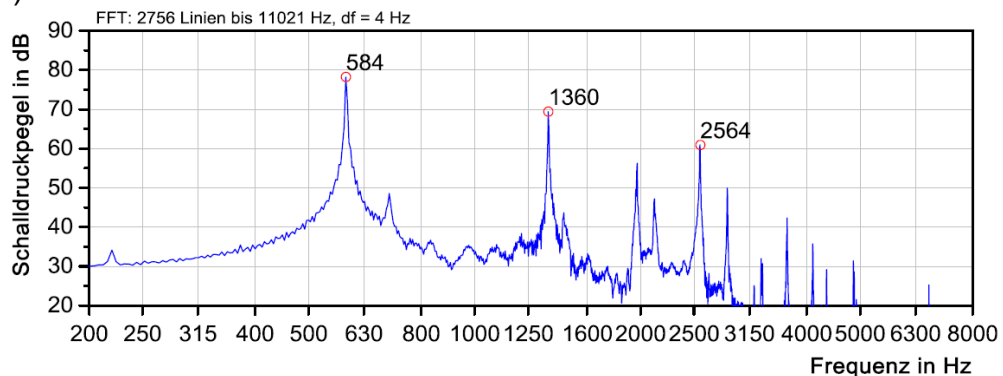

Abbildung 6: Abklingverhalten von Stahlmanteltragrollen der Durchmesser 159-219 mm und einer innen gedämpften Tragrolle (#201) im Vergleich zu einer Rolle mit Kunststoffmantel sowie dem Verhalten einer Bronzeglocke

Die Wirkung solcher Maßnahmen bezogen auf die Dämpfungseigenschaften der Tragrolle können durch einen mechanisch einfachen Anschlagversuch nachgewiesen werden. Die ermittelten Kenndaten erlauben eine quantitative Bewertung der akustischen Eigenschaften des Tragrollenmantels und lassen bei vergleichbaren mechanischen Anregungen in der Anlage geringere Geräuschemissionen an Gurtförderanlagen erwarten. [2]

2.3. Erfassung der Tragrollengeometrie

Das Abrollverhalten einer Tragrolle hat einen bestimmenden Einfluss auf die Lärmemission dieser. Unstetigkeiten des Tragrollenmantels bewirken durch das Abrollen am Fördergurt eine mechanische Körperschallanregung, welche zur Abstrahlung von Luftschall führen kann. Um die Rundlaufeigenschaften von Tragrollen genau zu beschreiben wird im Rahmen der Tragrollenprüfung eine klassische Rundlaufprüfung an drei Stellen des Tragrollenmantels durchgeführt (Abb. 6).

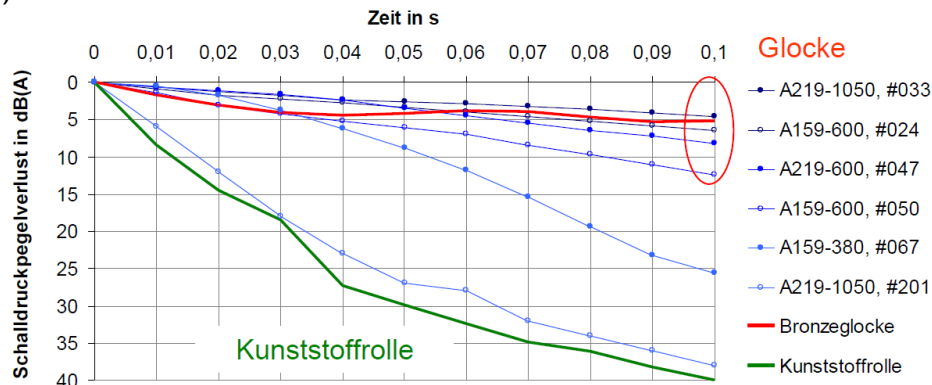

Abbildung 6: Messaufbau der Rundlaufprüfung

Dabei hat sich gezeigt, dass die ermittelte Rundlaufabweichung nicht ausreicht um Rückschlüsse auf die zu erwartende akustische Wirkung der Tragrollen zu erhalten. So zeigten Tragrollen mit gleichgroßen Werten für die Rundlaufabweichung Unterschiede von bis zu 10 dB(A) in der Schallemission während eines Prüflaufes am TPS.

Um die Geometrie des Tragrollenmantels genauer zu beschreiben wurde ein Verfahren entwickelt, mit dem aus der gemessenen Rundlaufabweichung die Größen Kreisformabweichung sowie Exzentrizität der Drehachse berechnet werden können (Abb. 7)

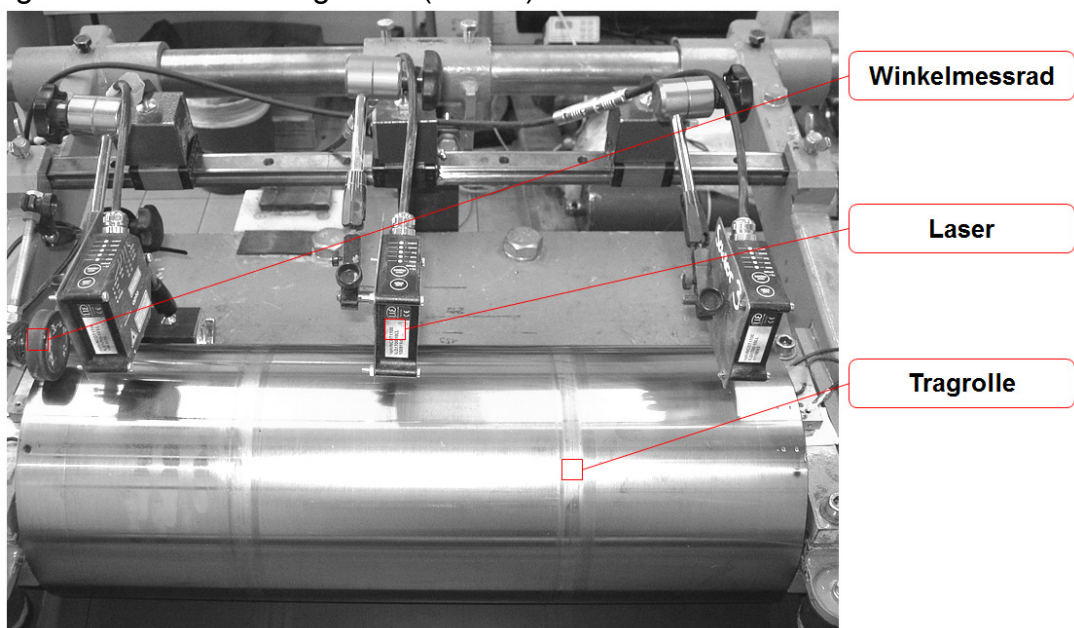

Abbildung 7: Rundlaufeigenschaften einer Tragrolle mit gewalztem Stahlmantel

3. Fazit

Die ermittelten Kenndaten erlauben eine quantitative Bewertung der akustischen Wirkung von Tragrollen und ermöglichen die Ableitung von Vorgaben für den Einsatz in Gurtförderanlagen. Basierend auf den Erkenntnissen umfangreicher Tragrollenprüfungen und Untersuchungen wurden die Lieferanforderungen der LEAG an Tragrollen um neue Parameter erweitert und präzisiert. Somit wird eine gezielte Beschaffung von geräuscharmen Tragrollen ermöglicht.

Die Umsetzung dieser Richtlinien zeigt in der Praxis bereits Erfolg. In Kombination mit einer zielgerichteten Instandhaltung sichern die akustischen und mechanischen Vorgaben für Tragrollen eine über mehrere Jahre mit der Neuausrüstung vergleichbare Geräuschemission für Gurtförderanlagen ab.

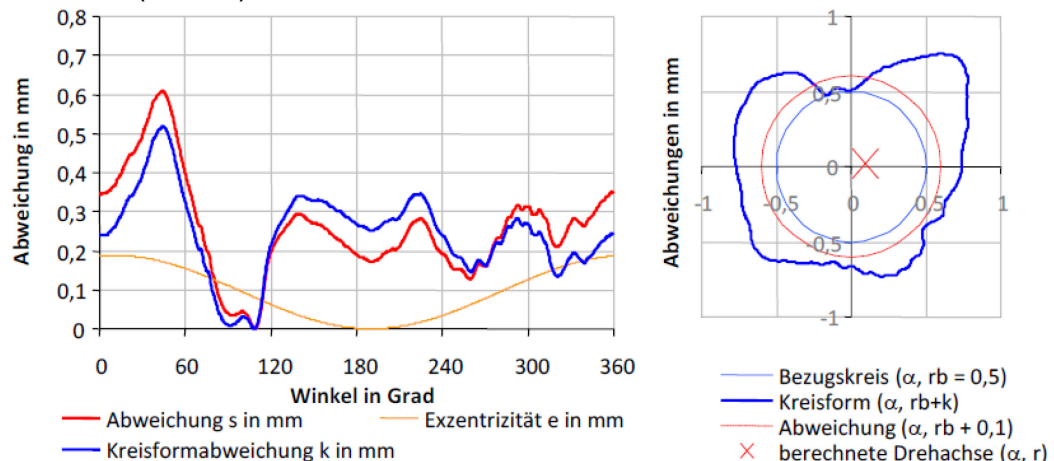
Literaturverzeichnis

- [1] Täschner D.: Untersuchungen der akustischen Wirkung von Tragrollen zur zielgerichteten Lärminderung an Gurtförderanlagen, Freiburger Forschungshefte, Bergbau, C 546, Technische Universität Bergakademie Freiberg, Freiberg, 2014
- [2] Henschler S., Rieder T., Täschner D. & Biegel P.: Abklingverhalten und Dämpfungseigenschaften von Tragrollen zur Lärminderung an Gurtförderanlagen, Tagungsbericht 21. Fachtagung Schüttgutfördertechnik 2016, Technische Universität München, Garching, 2016

36. UNTERSUCHUNGEN ZUR ENERGIEEFFIZIENZ BEI DER SPANENDEN BEARBEITUNG

Sylvio Simon (BTU), Andreas Brill (BTU), Steffen Wichmann (BTU)

Institut für Maschinenbau und Management, Fakultät 3, BTU C-S

Einleitung

Von der BTU Cottbus – Senftenberg und der TU Liberec sind in einer Kooperationsstudie Untersuchungen über den Zusammenhang von Kühlschmierstoffen auf die Energiebilanz und Oberflächenrauheit von spanend bearbeiteten Werkstücken durchgeführt worden [1]. Dabei wurden die Spanungsparameter und die angewandten Kühlschmierstoffe für die Untersuchungen variiert. Von der TU Liberec konnten hierfür Ergebnisse über Schnittkräfte und Schnittleistungen beim Schlichtdrehen und Schlichtfräsen unter Verwendung verschiedener Kühlschmierstoffe, Schmiermittelmengen und konstanten Spanungsparametern erzielt werden. Dieser Artikel befasst sich nun mit den bisherigen Ergebnissen der BTU Cottbus – Senftenberg. Das Ziel der Untersuchungen ist die Optimierung des Spanvorganges und der verwendeten Kühlschmierstoffe und ihrer angewendeten Mengen. Dadurch ist es möglich die Energiebilanz spanender Werkzeugmaschinen besser einzuschätzen und zu optimieren. Hierzu sind Versuchsreihen aufgenommen und die Schnittkräfte sowie Maschinenleistung gemessen worden. Im Gegensatz zu den Untersuchungen der TU Liberec werden bei den Untersuchungen der BTU Cottbus – Senftenberg die Spanungsparameter bei Verwendung einer Minimalmengenschmierung variiert.

Keywords: spanende Bearbeitung; Drehen und Fräsen; Prozessflüssigkeit; Minimalmengenschmierung (MMS)

Für die Untersuchungen kam eine Drehmaschine vom Typ Harrison M250 zum Einsatz. Dazu werden ein Baustahl S235 und ein Vergütungsstahl C45E mit unterschiedlichen Bearbeitungsparametern längsgedreht. Für die Versuchsreihen sind nacheinander Vorschub, Drehzahl, Einstellwinkel sowie Schnitttiefe verändert worden. Für jeden Spanungsparameter wird eine Versuchsreihe mit Trockenbearbeitung und mit Minimal-



Abbildung 7: Wendeschneidplatte mit Eckenradius r

mengenschmierung aufgenommen. Weiterhin kommen für die Versuche Wendeschneidplatten mit unterschiedlichen Eckenradien zum Einsatz (vgl. Abb. 1). Der Eckenradius wird für die Untersuchungen zwischen 0,2 mm und 0,4 mm variiert. Während der Versuchsdurchführung werden die jeweilige Schnittkraft und die Wirkleistung der Drehmaschine aufgezeichnet. Mithilfe der gemessenen Schnittkraft wird die Schnittleistung berechnet und der Wirkungsgrad für jeden Spanvorgang bestimmt. Im Folgenden werden die bisherigen Ergebnisse einer Trockenbearbeitung des S235 und des C45E dargestellt und erläutert.

Versuchsreihe Vorschub

Den Wirkungsgrad der Drehmaschine in Abhängigkeit vom Vorschub bildet Abbildung 2 ab. Sie veranschaulicht, dass der Wirkungsgrad der Drehmaschine mit zunehmendem Vorschub ebenfalls zunimmt. Hierbei ist es irrelevant welcher Werkstoff oder welcher Eckenradius für das Werkzeug gewählt wird. Aus dem Diagramm lässt sich ein fast linearer Anstieg des Wirkungsgrades mit zunehmendem Vorschub erkennen.

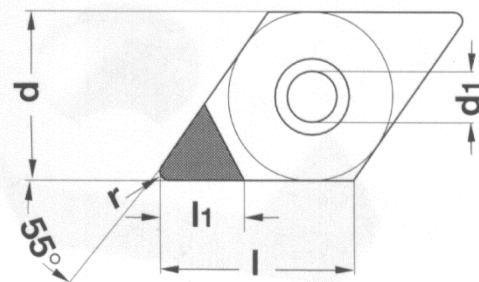

Abbildung 2: Diagramm 1, Versuchsreihe Vorschub

Auffällig ist, dass der Wirkungsgrad mit zunehmendem Vorschub bei der Bearbeitung eines Vergütungsstahls günstiger ausfällt. Mit steigendem Vorschub werden des Weiteren bessere Wirkungsgrade beim Spanen ohne Kühlschmierstoffe erzielt.

Versuchsreihe Drehzahl

Durch eine Variation der Drehzahl ist ein erwartungsgemäß ähnlicher Zusammenhang zwischen Wirkungsgrad und Drehzahl wie schon für die Versuchsreihe Vorschub zu erkennen. Dies veranschaulicht Abbildung 3. Mit abnehmender Drehzahl der Maschine wird auch der Wirkungsgrad geringer. Ebenfalls ist ein fast linearer Zusammenhang für eine Trockenbearbeitung erkennbar. (vgl. Abb. 3) Auch hier lässt sich kein direkter Zusammenhang von Werkstückwerkstoff und Eckenradius des Meißels ableiten.

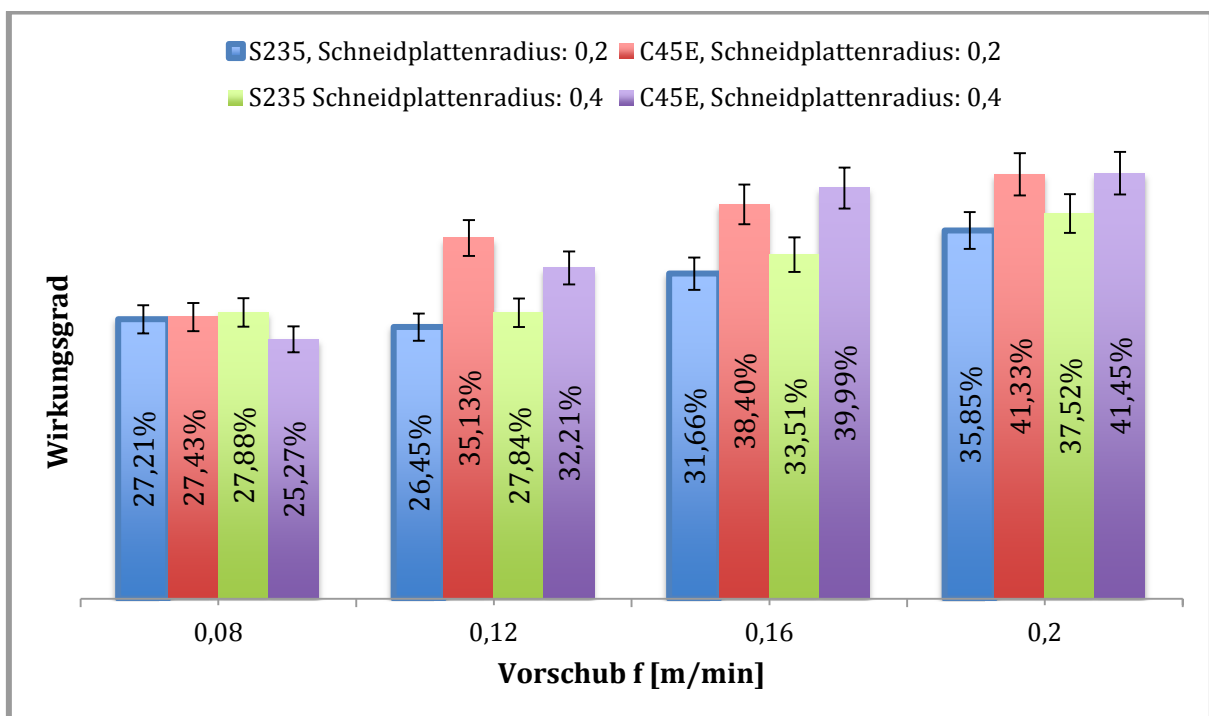

Abbildung 3: Diagramm 2, Versuchsreihe Drehzahl

Lediglich die Versuchsreihe des Vergütungsstahls mit einem Schneidplattenradius von 0,2 mm lässt für alle Drehzahlen einen höheren Wirkungsgrad erkennen. Die Abnahme des Wirkungsgrades entspricht der Leistungsaufnahme der Maschine und ist bei einer Trockenbearbeitung ähnlich wie bei einer Veränderung des Vorschubes.

Versuchsreihe Einstellwinkel

Eine Veränderung des Einstellwinkels hat die Wirkungsgrade wie sie in Abbildung 4 dargestellt sind zur Folge. Bemerkenswert bei dieser Versuchsreihe ist, dass der Wirkungsgrad des Spanprozesses mit abnehmendem Einstellwinkel und einem Eckenradius der Schneidplatte einen Anstieg erfährt. Unabhängig vom Werkstückmaterial. Wohingegen die Versuche mit einem Schneidplattenradius von 0,4 mm einen unveränderten Wirkungsgrad erkennen lassen.

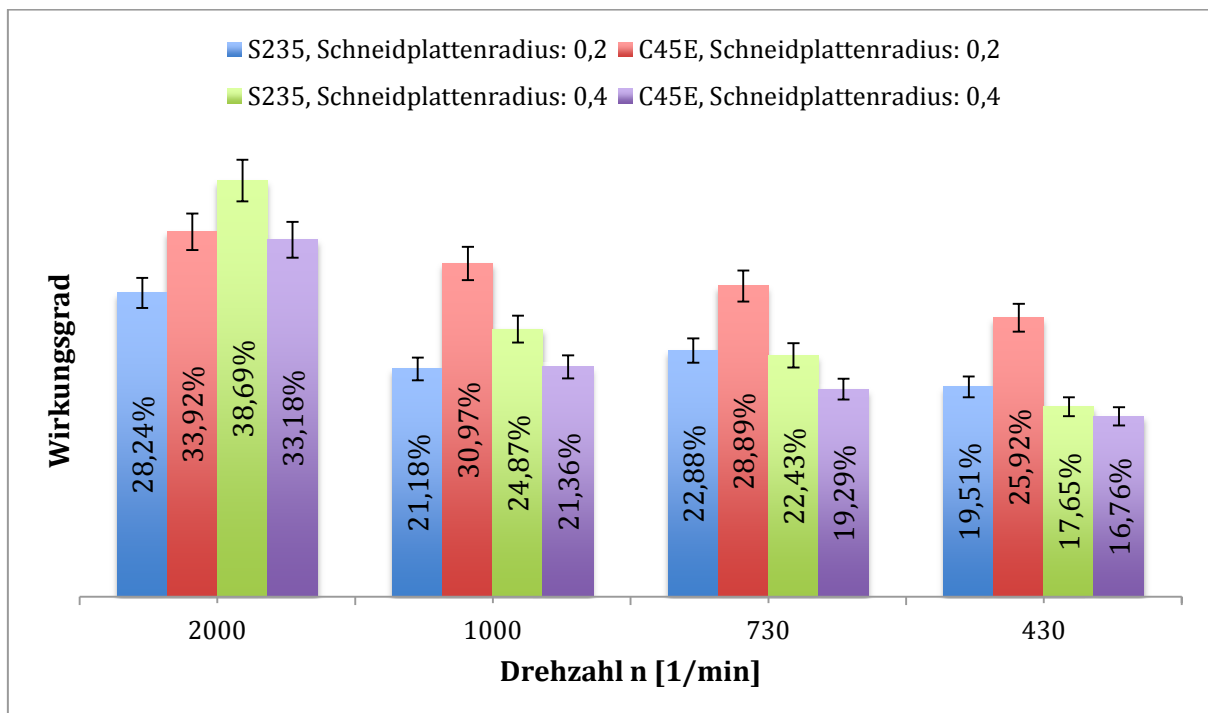

Abbildung 4: Diagramm 3, Versuchsreihe Einstellwinkel

Aus dieser Versuchsreihe geht hervor, dass der Wirkungsgrad auch bei einer Trockenbearbeitung durch Drehen positiv beeinflusst werden kann. Dies ermöglicht, bei festgelegten Spanungsparametern durch anpassen des Einstellwinkels einen optimalen Wirkungsgrad für den Spanvorgang zu erzielen.

Versuchsreihe Schnitttiefe

Abbildung 5 stellt den Wirkungsgrad des Spanprozesses bei unterschiedlichen Schnitttiefen dar. Der Wirkungsgrad nimmt hierbei mit abnehmender Schnitttiefe ab. Besonders sind die Wirkungsgrade die erreicht werden, sobald die Leistungsgrenze der Maschine erreicht wird. Die Wirkungsgrade bei einer Schnitttiefe von $a_p = 0,5$ mm liegen in einem Bereich von 44 % bis 54 %. Aufgrund der geringen Nennleistung der verwendeten Maschine ist hier aber kein längerer Spanvorgang möglich. Die 1,3 kW Nennleistung sind bei einer Schnitttiefe von $a_p = 0,5$ mm überschritten und der Hauptantrieb kippt über seinen Sattelpunkt ab.

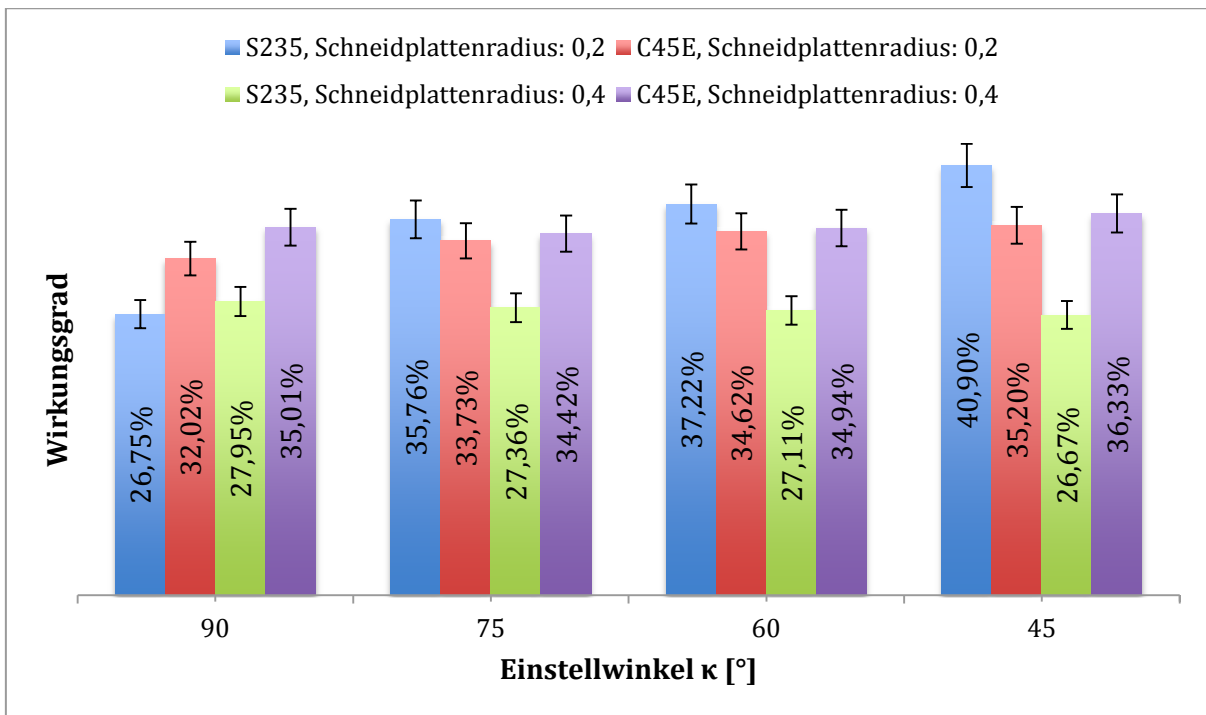
Diese Versuchsreihe veranschaulicht, dass die Auslastung der Maschinenkapazitäten einen erheblichen Einfluss auf den Gesamtwirkungsgrad beim Spanen hat. Hierbei spielt der Werkstückwerkstoff einen nicht unerheblichen Einfluss.



Abbildung 5: Diagramm 4, Versuchsreihe Schnitttiefe

Der Wirkungsgrad für das Spanen eines Vergütungsstahls ist mit zunehmender Schnitttiefe günstiger. Jedoch erreicht hier die Maschine auch eher ihre Nennleistung. Es ist aber möglich durch die Verwendung unterschiedlicher Eckenradien am Schneidwerkzeug die Schnittleistung und somit den Wirkungsgrad zu beeinflussen.

Für alle Diagramme sind die Fehlerindikatoren mit 5 % angegeben. Damit werden Leistungsschwankungen des Motors und des Netzes ausgeglichen.

Zusammenfassung

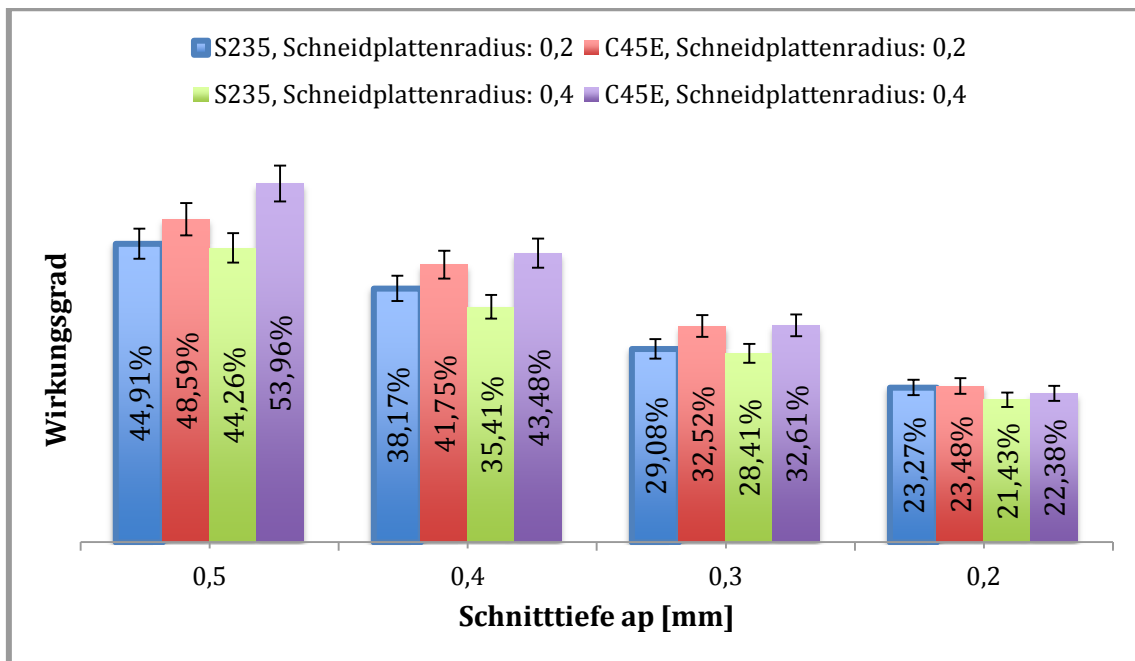
Erste Ergebnisse der Untersuchungen zeigen, dass durch die Veränderung der allgemein bekannten Spanungsparameter eine Anpassung des Wirkungsgrades möglich ist. Besonders durch eine Veränderung des Einstellwinkels ist eine Optimierung des Spanprozesses bei einer Trockenbearbeitung einfach umsetzbar. Jedoch führt eine Trockenbearbeitung beim Spanen zu erhöhtem Werkzeugverschleiß und großer Wärmeentwicklung. Gerade diese Auswirkungen werden durch die Verwendung von Kühlschmierstoffen stark reduziert. Die weiteren Untersuchungen befassen sich mit der Verwendung einer Minimalmengenschmierung der aufgeführten Versuchsreihen. Durch die Kooperation mit der TU Liberec können so weitere Aussagen für die Anwendung einer Minimalmengenschmierung beim Spanen sowie Aussagen über Spanungsparameter für eine verbesserte Energiebilanz von spanenden Werkzeugmaschinen formuliert werden.

[1] Sylvio Simon, Steffen Wichmann, Matthias Führer; Energieeffizienz in der spanenden Bearbeitung - Energy Efficiency in Metal-cutting Manufacturing, Neseff Tagung Moskau Smolensk 2016; ISBN 978-5-91412-313-7

37. ENERGY SAVING REGULATIONS IN GERMANY, HISTORY – STATUS – FUTURE

Prof. Dr. Schütz

Brandenburg University of Technology (BTU) Cottbus – Senftenberg
Faculty 6, Building technologies

Abstract

In 1972 the oil price increases sharply in Germany and other countries and the energy crisis was declared. Cars were not allowed to drive on motorways during weekends. The Club of Rome published his worldwide respected paper about the limit of growth and first green demonstrations were arranged in Germany. These economic and political movements motivates the state to start energy saving regulations. Starting from 1976 the first energy saving regulation was established. From “heat insulation ordinance” to “energy saving ordinance” and “renewable energy heat act” of today the requirements on energy insulation and energy efficiency were steadily increased.

The definition of energy got more complex and terms like “useful energy”, “final energy” and “primary energy” are nowadays standard energy definitions for planning of buildings. The passive houses, including energy gain by the building itself, will get standard in the near future.

The article will mention the regulations and their main physical aspects. Development of mean energy parameters over time will be presented. Visible future developments in energy regulations will be explained.

Start and motivation for energy saving

In 1972 the oil price increases sharply in Germany and other countries and the energy crisis was declared, see figure 1. Cars were not allowed to drive on motorways during four Sundays, see figure 2. The speed for cars was limited to 100 km/h over six months. To the audience it was shown that energy gets expensive and saving of energy shall be done. Although the real saving of oil was marginal the impression to the inhabitants was not.

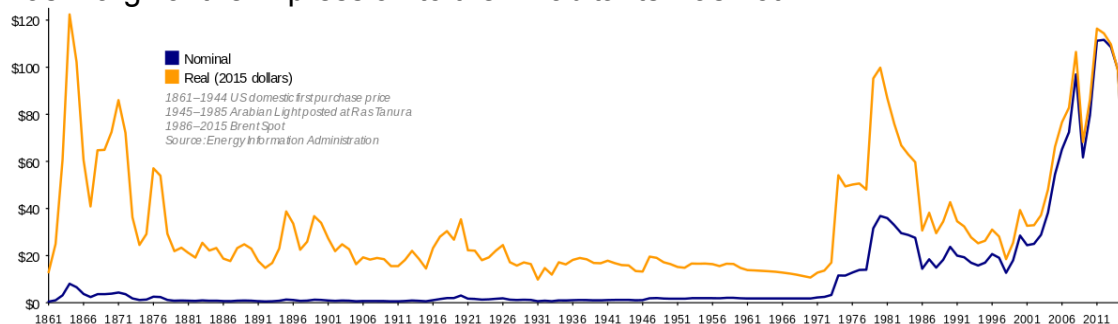

Figure 1 oil price from 1861 to 2012

https://commons.wikimedia.org/wiki/File:Crude_oil_prices_since_1861.png



Figure 2 empty motorway in Germany during the oil crises. CC-Lizenz (BY 2.0),
Quelle: <http://piqs.de/fotos/69696.html>

In 1972 The Club of Rome published his worldwide respected paper about the limit of growth. All over the world the idea of limit growth and the limited resources on earth are discussed. Starting from 1970 first green demonstrations were arranged in Germany. Although they do not represent the main thinking in Germany they showed a growing mode against further growth and further destroying of nature.

Today we can see the current damage of nature and the pollution of air in growing countries and mega cities. In the seventies the pollution in Germany was bigger than today. Smog and other impacts on the environment were visible.

These economic and political movements combined with the real visible damage of nature motivates the state to start energy saving regulations. In 1976 the energy conservation act (Energieeinsparungsgesetz) was established. Based on this regulation the first heat insulation ordinance (Wärmeschutzverordnung) came in action. Single and mean heat transfer values were limited for buildings. In 1984 the second heat insulation act was set in action. The mean heat transfer value of the building was restricted according to the ratio of outer surface to the volume of the building. With the third heat insulation ordinance additionally to the mean heat transfer value depending on envelop the heating demand of the building is restricted. So not only the physical values of the building but also ventilation, inner and outer heat loads are accounted for. Parallel to the heat insulation ordinance the heating system ordinance from 1978, 1982, 1989, 1994 and 1998 regulates the construction and operation of the heating system. The main regulations to save energy were:

- requirements of minimum efficiency of boilers,
- exhaust energy losses were restricted,
- the thickness of the insulation on pipes was defined,
- the supply temperature of the heating system was related to the outdoor temperature,
- the boiler shall be time controlled so night reduction of supply temperature is possible,
- each single room shall have a room temperature control,
- the hot water circulation pump shall have a time control to switch it off by night,
- the hot water temperature is restricted to maximum 60°C

Now the nature of energy was discussed and new definitions of energy were established. The usable energy (Nutzenergie) was declared to describe the energy to heat the room and get the desired temperature. Outer and inner loads, losses by transmission and ventilation are calculated in order to determine the usable energy over the heating period to heat the room. To deliver the usable energy normally boilers are used. The losses due to heat generation by boilers or other equipment, heat storage in hot water tanks, heat transportation in pipes through the building and heat transfer from the heating system to the room. The efficiency of each single part of the heating system was calculated and the losses were determined. So to provided the usable energy the final energy has to be bought or delivered to the building. Due to losses the final energy is bigger as the usable energy. But the final energy has to be get from earth in form of crude oil, natural gas or coal. This energy coming from ground is called primary energy. Due to losses by transport and changing the quality of the energy materials like from crude oil to light oil the primary energy is bigger than the final energy.

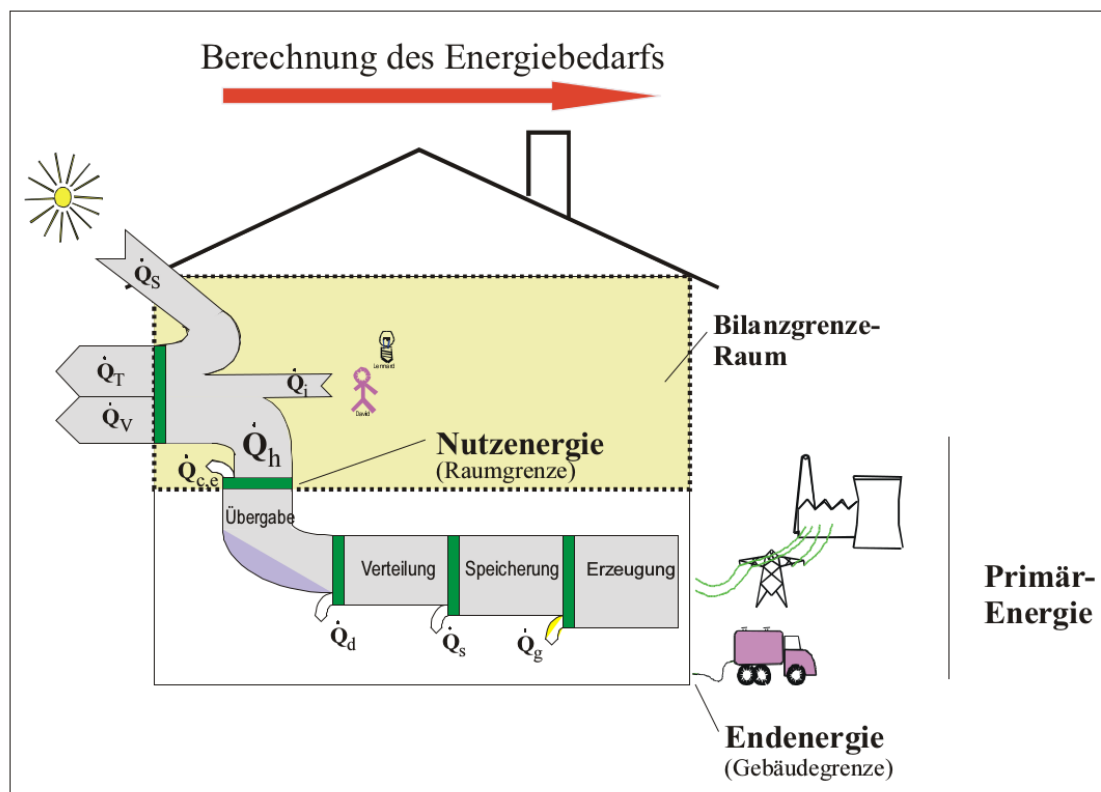

Figure 3 definition of usable energy, final energy and primary energy from DIN V 4701-10

In 2001 the first energy saving ordinance was established. The energy insulation ordinance and the heating system ordinance were combined. Because the building envelope with the heat transfer values and the heating system with its efficiency are both incorporated in the calculation the planning engineer can optimize in two ways the energy efficiency of the building. If high heat transfer values of the building envelope are built the heating system has to be very efficient in order to meet the requirement or vice versa. The primary energy demand has to cover heating and hot water. The air tightness of the building envelope is restricted. Thermal bridges have to be avoided. Some requirement for existing buildings were defined.

In 2007 the second energy saving ordinance was published. The primary energy demand has to cover heating, hot water and additionally cooling, ventilation and illumination. An energy performance certificate was defined. The user of the building shall get information about the final and primary energy demand. Simple scales illustrated with numbers and colors combined with reference values for comparison permit even non energy experts to understand the energy demand of the building.

ENERGIEAUSWEIS für Wohngebäude

gemäß den §§ 16 ff. Energieeinsparverordnung (EnEV)

Berechneter Energiebedarf des Gebäudes

2

Energiebedarf

Endenergiebedarf

_____ kWh/(m²·a)

CO₂-Emissionen ¹⁾ _____ kg/(m²·a)

_____ kWh/(m²·a)

Primärenergiebedarf („Gesamtenergieeffizienz“)

Nachweis der Einhaltung des § 3 oder § 9 Abs. 1 EnEV ²⁾

Primärenergiebedarf		Energetische Qualität der Gebäudehülle	
Gebäude Ist-Wert	_____ kWh/(m ² ·a)	Gebäude Ist-Wert H _f	_____ W/(m ² ·K)
EnEV-Anforderungswert	_____ kWh/(m ² ·a)	EnEV-Anforderungswert H _f	_____ W/(m ² ·K)

Endenergiebedarf

Energieträger	Jährlicher Endenergiebedarf in kWh/(m ² ·a) für			Gesamt in kWh/(m ² ·a)
	Heizung	Warmwasser	Hilfsgeräte ³⁾	

Sonstige Angaben

Einsetzbarkeit alternativer Energieversorgungssysteme

nach § 5 EnEV vor Baubeginn geprüft

Alternative Energieversorgungssysteme werden genutzt für:

Heizung Warmwasser

Lüftung Kühlung

Lüftungskonzept

Die Lüftung erfolgt durch:

Fensterlüftung Schachtlüftung

Lüftungsanlage ohne Wärmerückgewinnung

Lüftungsanlage mit Wärmerückgewinnung

Vergleichswerte Endenergiebedarf

4)

Erläuterungen zum Berechnungsverfahren

Das verwendete Berechnungsverfahren ist durch die Energieeinsparverordnung vorgegeben. Insbesondere wegen standardisierter Randbedingungen erlauben die angegebenen Werte keine Rückschlüsse auf den tatsächlichen Energieverbrauch. Die ausgewiesenen Bedarfswerte sind spezifische Werte nach der EnEV pro Quadratmeter Gebäudenutzfläche (A_W).

Figure 4 energy certificate from EnEV 2007

Energy inspection of ventilation devices was established. Every 10 years the ventilation device has to be checked to realize energy saving measures. Especially the specific fan power SFP

as characteristic number, electrical energy demand of one ventilator divided by the transported volume flow, is used to classify the energy efficiency of the ventilation device. Maximum values of the SFP were defined.

170

In 2009 a new energy saving ordinance and additional the renewable energy heat act is published. The concept of a reference building is introduced. On paper the building is built with the same geometry and same windows as on the architecture plan. But reference values for the envelope heat transfer values and heating, cooling, ventilation and illumination system are defined. The primary energy demand is computed with the reference values. The real building with possible different heat transfer coefficients and other construction of building facilities shall have no bigger primary energy demand than the reference building. Some reference definitions are listed below:

- u_{wall} 0,28 W/m²K
- u_{ground} 0,35 W/m²K
- u_{roof} 0,20 W/m²K
- u_{window} 1,30 W/m²K
- air tightness n₅₀ = 3 or 1,5 1/h
- condensing boiler
- supply/return temperature 55°C/45°C
- proportional temperature range of radiator regulation device 1K
- solar hot water production
- exhaust ventilation regulated by demand with DC-motor

Electricity produced by photovoltaic modules at the building reduce the primary energy demand of the building.

The renewable energy heat act demands the use of renewable heat for heating. The following facilities or measures are possibilities to meet the requirements:

- ground water or air heat pump
- thermal solar collectors
- bio mass (wood, gas, fuel,...)
- heat recovery (ventilation,...)
- combined heat and power
- evaporation cooling
- ground cooling
- improved insulation by 15%

In 2014 the fourth energy saving act was published. Primary energy demand was not changed in 2014. But in 2016 the primary energy demand was reduced by 25%.

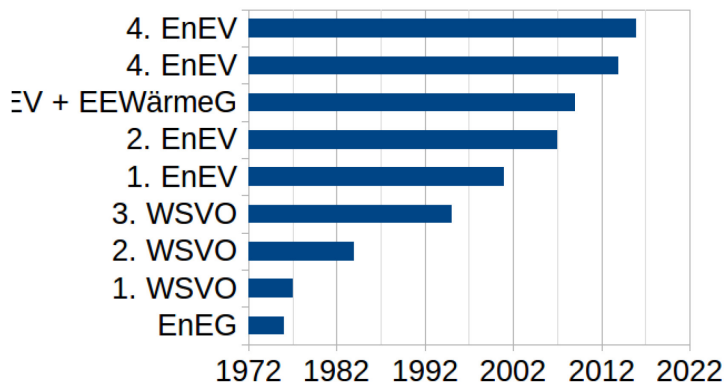

Figure 5 development of energy saving regulations over time

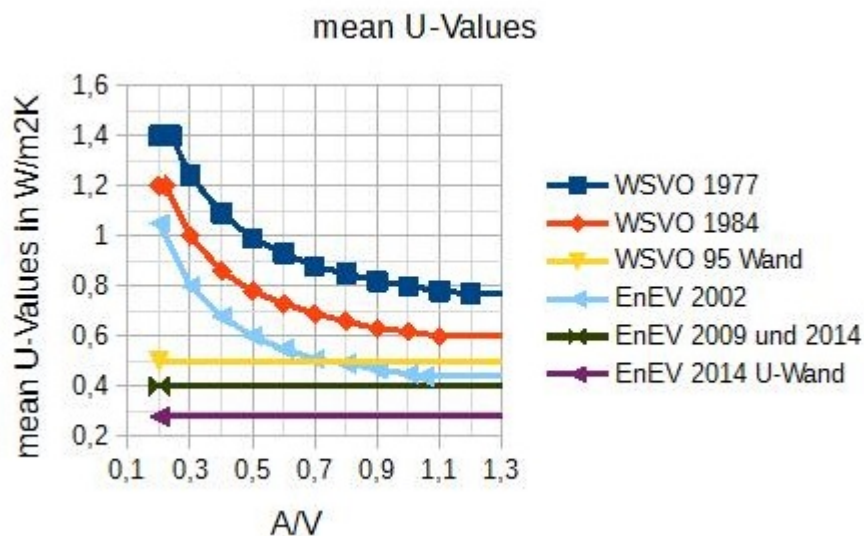

Figure 6 development of heat transfer mean values and wall values

The development in time of the mean heat transfer values can be seen in figure 9. Some regulations have a mean value of the heat transfer value depending on the outer surface of the envelope divided by the volume of the building. Other regulations give constant values for mean and wall values. The main result is the reduction of the heat transfer values from around 0.8 W/m²K to 0.28 W/m²K during a time period of around 37 years.

In 2010 the European Community has given the Directive Energy Performance of Buildings. For newly constructed buildings the “nearly-zero-energy-building” is introduced and required after 2021. In 2013 the German energy conservation act adopted the “nearly-zero-energy-building” for buildings constructed after 2020.

In the near future it is expected that the heat saving ordinance, the renewable energy heat act and the energy conservation act are combined to one regulation. Change is not expected before the elections in Germany in 2017. The “nearly-zero-energy-building” is expected to be defined in detail. A first imagination of the definition may be given:

- the energy demand shall be very low and the necessary energy shall be renewable energy obtained close to the building

Summarizing the development of energy saving on buildings in Germany concludes around 50 year (1976 to 2020) of discussion, dispute and results concerning energy saving. There exist 135 pages of regulations and 1177 of national standards. The standards of buildings concerning energy and quality was rising. Additionally the construction cost was steadily rising. The operation cost of the building concerning energy were reduced although the energy prices rise. These statements are true for newly constructed buildings. New challenges for electrical power generation, secure of environment and change of existing buildings may be subject of future discussion, dispute and possible results.

38. OPTIMIERUNG EINER VERSUCHSANLAGE ZUR ELEKTRISCHEN AUTARKIE

Daniel Britz (BTU), Prof. Dr. oec. Hubertus Domschke

Institution: ifn Anwenderzentrum GmbH, BTU Cottbus - Senftenberg

Abstract: Die weitgehend autarke Energieversorgung von Siedlungs- und Gewerbestrukturen mit eigenerzeugter Strom-, Wärme- und Wasserversorgung sind weltweit fokussierte Entwicklungsziele zahlreicher Unternehmen. Im Zuge dieser Entwicklung hat sich das Bündnis autartec® als Ziel gesetzt, der Öffentlichkeit ein zumindest semiautarkes ufernahes „schwimmendes autartec® Haus“ zu demonstrieren. Um das spätere Zusammenspiel der semiautarken Energieversorgung dieses Demonstrators zu planen und zu optimieren, wurde am ifn Anwenderzentrum in Lauchhammer ein skalierter Versuchsstand entwickelt und geplant.

Die unterschiedlichsten Energieerzeugungs- sowie Energieverbraucher-technologien können hierbei untersucht und aufeinander angepasst werden. Vorhandene Komponenten wurden optimiert und stellenweise durch einer redundanten Lösung erweitert. Dazu wurden ein Energiemanagement sowie eine Brennstoffzellen-Steuerung entwickelt. Das System wurde mit einer größeren Messwerterfassung erweitert und eine Integration eines Rechenmodells erfolgte.



Abbildung 1: autarkes, schwimmendes Haus [autartec®].

Kontakt:

www.autartec.com

39. PRINCIPLES OF CREATION THE ENERGY-EFFICIENT RURAL AREA COMMUNITIES WITH BALANCED MATERIAL AND ENERGETIC FLOWS

Dr. Prof. Mykola Savyskyi¹, Ph. D. Post-Doc Maryna Babenko²

*SHEI "Prydneprovs`ka State Academy of Civil Engineering and Architecture",
Dnipro, Ukraine, pgas.dp.ua*

Email: 1sav15@ukr.net, 2babenko.marina@yahoo.com

ABSTRACT

In 2015 the UN adopted 17 sustainable development goals, the most important are: agriculture and food security, economic growth and social inclusion, prevent disease and preserve health. The agricultural and construction sectors is playing the main role in solving these problems. **The main idea** is to create a stable and functioning energy-efficient communities with closed-cycle of material and energy and open information flows, the potential of which will be sufficient to meet the needs of the population while minimizing environmental impact. **The peculiarity** of the presented research is the focus on the wide implementation of environmentally clean and renewable local materials as well as innovative energy-efficient equipment rational adaptation. The research provides the strategy milestones to create the complex solutions for achieving 100% utilization or recycling taking into account all stages of constructions life cycle.

Keywords: *rural area, sustainable development, circular economy*

Main text:

Today, the agricultural sector is one of the most important branches of economy in Ukraine. In 2015 only agriculture and information technology showed growth during the crisis. Equally important is the fact that the agriculture industry also creates jobs places. Now Ukrainian agricultural sector employs more than 14 mln. people and only 620,000 of them working in large farms - agricultural holdings [1].

Targeting of large agricultural holdings to increase the export potential of grain and industrial crops leads to a growing problem of employment in rural areas, because the cost of labor per hectare of crops is 10 times lower than in the cultivation of vegetables. Industrial production less labor-intensive and can provide jobs to 100% coverage of all Ukrainian lands by 2 mln. people. This means that the remaining 12 mln. farmers will lose their source of income. Promotion of agricultural holdings, which focuses on government financial support, accelerate the destruction of villages and villagers. According to statistical data for the years 1991-2012 Ukraine map 641 disappeared villages [2].

Recent events related to the annexation of the Crimea, military actions in eastern Ukraine led to the displacement of large numbers of people in need of resettlement and employment. One possible solution to this problem is the

migration of people to the countryside and employment in the agricultural, touristic, IT or other sectors.

The development strategy of the agricultural sector of Ukraine should formulate a clear and understandable for the entire population a strategic goal - a promising position parameters sectors of the agricultural sector and, above all, rural development and productive employment of its inhabitants. In Ukraine there are 47 state programs have long had to answer all the above questions. However, their effectiveness for various reasons is extremely low.

It is extremely important for the agricultural sector is not only increase production but also the development of rural social infrastructure, housing, roads, schools, medical institutions, shops, processors, cultural institutions.

Thus, development, aimed at modernizing the agricultural sector through the development of agricultural and construction technologies are extremely important for Ukraine.

The village is a center of preservation of national traditions, respect for the family and Communications generations, which has a decisive influence on the formation of Ukrainian mentality. Ukraine, above all, is an agricultural state, its formation took place under the influence of processes taking place in the villages. At the present stage before an independent Ukrainian state is not an easy task revival of the village.

Modernization of the agricultural sector of Ukraine is possible through the large scale implementation of circular economy principles – approach to nearly zero waste and autonomy that is a natural reaction to the situation in Ukraine, which is experiencing financial, social, political, environmental, energy, demographic, housing, food crisis. **The concept is to create a stable and functioning energy-efficient communities with closed-cycle of material and energy and open information flows, the potential of which will be sufficient to meet the needs of the population while minimizing environmental impact.** Research dedicated to the establishing the principles of this concept realization is based on analysis of development trends of globalization and the role of Ukraine in the global division of labor. Main idea is based on the principles of balanced sustainable development, the characteristics of the modern post-industrial information society ("knowledge society"), modern technologies of natural farming, innovative energy efficiency, construction and information technology.

The basic principles of creation energy-efficient rural area communities with balanced material and energetic flows: environmentally friendly, high-tech, business and social activity of citizens, comprehensive development of man.

The concept assigned ethno-technology of green building, eco-low-tech, eco-Hitech, smart technology and modern agricultural technologies. It is considered the symbiosis of innovative building technologies, which includes the creation of residential and industrial eco-buildings on the basis of stages of their life cycle (extraction of raw materials and production materials, design, construction, operation and recycling or reuse of waste products) and agricultural technology (as a source of building raw materials and energy in order to minimize environmental impact).

The proposed approach is to apply the principles of circular resource-efficient economy which provides highly efficient use of natural resources and full

utilization of agricultural waste through reuse and recycling in building materials, energy inputs and fertilizers.

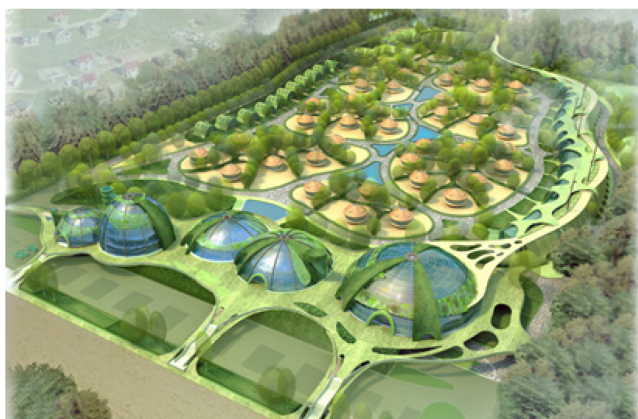

Fig. 1. The variation of architectural and spatial organization of energy-efficient rural area communities with balanced material and energetic flows

Environment technologies are considered, and aimed to create the conditions for harmonious relations inside the energy-efficient community, which are beneficial to the environment as well. In the all stage of the community formation and especially during the design level, it is proposed to apply the ecological standards as a basic.

Adaptability is a milestone for rural area reformation in the context of creating an effective symbiosis of classic and new technologies in construction, public utilities, energy, agriculture, science, communication, education, and others.

Business and social activity of inhabitants: the foreseen conditions for stimulating entrepreneurship, efficient use of resources and active life position.

Human development: with the focus of real labor market needs and community needs to ensure the effective functioning it is presuming the conditions for human development, both professionally and in personal terms at the advanced educational technologies.

Scale of community - optimal number of residents must provide the conditions in which all the inhabitants know each other while everyone is aware that may affect the development of community. According to reports, the upper limit of the group is approximately 500, and the optimal number is 300 people. Considering the average family composition 3 - 4 people, the optimal number of individual residential buildings is 70 - 100 pieces. It is also depends on special purpose of rural area and construction design solutions.

Green building. Today the house-stock end-users are not enough aware about particularity of applying principles of sustainability for their buildings, especially in countryside while there these technologies are easier to realize. Development of construction which will have simple constructive schema, will use local natural and accessible in countryside building materials, will combine different functions and will be energy-efficient and autonomic – will show affordability NZE&WBs for end-users in rural area [3].

PSACEA is actively working on a number of directions including the development of energy-efficient design solutions of low-rise buildings using organic materials, the advancement of standards of sustainability. Developed systems were implemented in the first in Ukraine residential house with extra

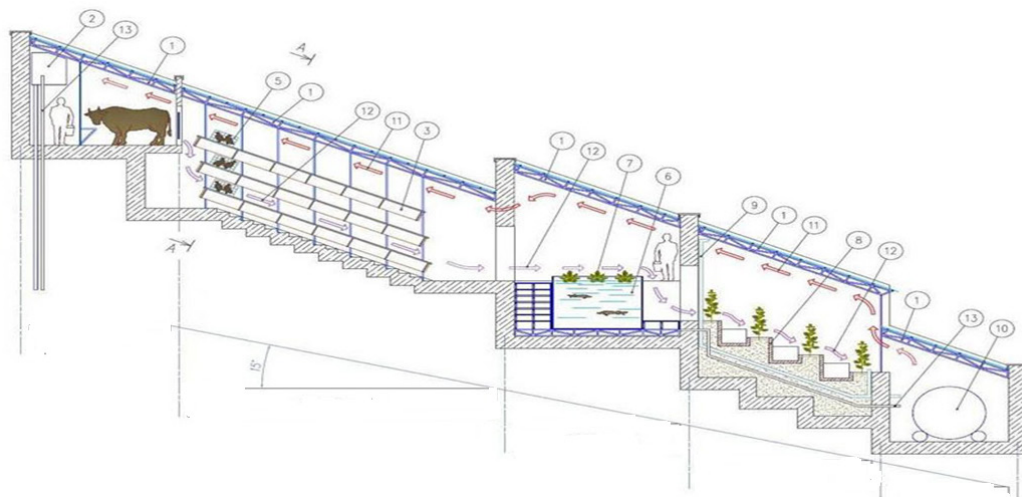

Fig.2. A possible scheme of industrial building for energy-efficient rural area communities with balanced material and energetic flows

- 1-frame metal; 2-transparent roof; 3 solar collectors; 4 capacity; 5 - sloped trays with vermicompost;
6- concentrated soil solution; 7 - a bowl of water for the fish; 8 - plant eyhorniya; 9 - wall beds; 10 - air ducts; 11 - pyrolysis oven; 12 - CO2 gas exchange channels; 13 - air channels; 14 - Vacuum tubes

To summarize, the development of eco-technologies in building combined with modern bio-agricultural technologies can provide high-quality Ukrainian affordable housing, decent safe and useful work with green technologies for land, tourism and scientific spheres; create a new ideology attractive to young restoring cultural heritage cultivating a healthy lifestyle and advanced thinking in accordance with the global trend of sustainable development.

References

- [3] M.Kalinchak. *There were Strategy of development of agrarian sector of Ukraine. El.resurs: <http://agrinews.com.ua/show/277774.html>.*
- [4] *Agroholdings will destroy the Ukrainian village. Resource: <http://agrinews.com.ua/show/278689.html>.*
- [3] Savytskyi M., Benderski J., Babenko M. *Heat engineering characteristics organic insulation with local materials/ Theoretical Foundations construction. Sb. scientific. Labor - Warsaw, 2012. - p. 373-376.*

40. Entwicklung und Optimierung von energieeffizienten Leichtlaufmobilen an der BTU Cottbus – Senftenberg

M. Eng. Christin Faulstich

Seit einigen Jahren fordert die Politik, unterstützt durch internationale Klimaabkommen und die Vorreiterstellung der Bundesrepublik Deutschland, Maßnahmen zur Verringerung des CO₂-Ausstoßes sowie zur Sicherung der Mobilität der Zukunft durch effizientere und alternative Antriebskonzepte. Um diese Forderungen umsetzen zu können und gleichzeitig den Ansprüchen der Kundinnen und Kunden gerecht zu werden, ist es notwendig, dass sich Ingenieurinnen und Ingenieure neues Knowhow im Bereich des Automobilbaus und der Antriebskonzepte aneignen.

Das Team Lausitz Dynamics der BTU Cottbus-Senftenberg beschäftigt sich seit 2008 mit der Optimierung energieeffizienter Leichtlaufmobile.

Im Jahr 2008 wurde ein Fahrzeug entwickelt, das als tragendes Element einen Aluminiumrahmen nutzte, an dem alle weiteren Bauelemente befestigt wurden. Als Weiterentwicklung des Fahrzeugs wurde ein Chassis aus einem Hartschaum-Kohlefaserverbund verbaut und anschließend eine Karosserie aus Kohlefaserverbund angefertigt. Durch diese Konzeptänderung konnte eine Gewichtsreduzierung von 140 kg auf rund 70 kg erreicht werden.

2011 wurde zusätzlich zur Veränderung des Faserverbundaufbaus eine freitragende Außenhaut entwickelt, damals aus mehreren CFK-Matten und heute bestehend aus einer CFK-Sandwichstruktur mit 10 mm Kevlar-Wabe. Durch diese Komponenten und der Weiterentwicklung der Brennstoffzellentechnologie konnte in den folgenden Jahren eine weitere Gewichtsreduzierung von 34 kg erreicht werden.

Neben der Forschung an verschiedenen Bauformen und Antriebskonzepten wurden unterschiedliche Energiekonzepte entwickelt. Zu Beginn der Forschung konnte der Luftwiderstandsbeiwert (cw-Wert) der Testfahrzeuge in den ersten drei Jahren von 0,8 auf 0,12 minimiert werden. Im Vergleich dazu hat ein Kleinwagen einen cw-Wert von ca. 0,3 und ein City-Fahrradfahrer rund 1,0.

Diese Reduktion wurde durch Strömungsfreiheit unter dem Fahrzeug und Verringerung der angeströmten Stirnfläche erreicht. Da die Testfahrzeuge überwiegend bei Geschwindigkeiten unterhalb von 30 km/h genutzt werden, war es zusätzlich unabdingbar den Rollwiderstand zu verbessern. Hierfür wurden Reifen und Lager auf mögliche Optimierungen untersucht. Parallel zu diesen Forschungen wurden verschiedene Kraftübertragungskonzepte betrachtet und erprobt. Als Beispiel wurde für ein Testfahrzeug des Teams Lausitz Dynamics eine Zahnradpaarung aus Kunststoff priorisiert. Positive Nebeneffekte hierbei sind die selbstschmierenden Eigenschaften der technischen Kunststoffe und die Gewichtsreduzierung im Vergleich zu metallischen Zahnradern.

Über die Jahre wurde parallel am Energiemanagement der Fahrzeuge geforscht. Hierzu zählen der Akku, das Batteriemanagementsystem und der Solar-Laderegler in der Kategorie solar-elektrischer Antrieb oder der Superkondensator samt Laderegler und Zellüberwachung bei der Nutzung einer mobilen Brennstoffzelle. Eine der wichtigsten Komponenten stellt der Motorcontroller dar. Nach Ermittlung des Arbeitspunktes muss der

Motorcontroller so gefertigt und programmiert werden, dass der Motor stets im Bereich des maximalen Wirkungsgrades betrieben wird. Dadurch können an Steigungen Spitzenverbräuche minimiert werden, indem der Motor nur bis zu einer maximalen Last betrieben wird und bei abschüssiger Strecke unnötige Leerlaufverluste durch Abschalten des Motors verhindert werden. Die Ansteuerung des bürstenlosen Drehstrommotors erfolgte anfänglich durch eine Blockkommutierung. Im späteren Verlauf der Forschung wurde die modernere Sinuskommütierung eingesetzt.

Durch diese umfassenden Forschungen im Bereich der effizienten Fahrzeugentwicklung konnten bereits nachfolgende Ergebnisse erreicht werden.

	2010	2011	2012	2014
Fahrzeug	SunCatcher Phase Two	Bat-LaDy	LaDy 2	Sun LaDy
Energy	Solar	Plug-In Battery	Plug-In Battery	Solar+ Battery
Beste Wertung km/kWh	0	456	732	839
entspricht km/l	0	4054	6313	7460

In der Tabelle 1 wird sichtbar, dass durch die Veränderung der Fahrzeugkonstruktion in den Jahren 2010 auf 2011 und 2011 auf 2012 eine Erhöhung der erreichten Entfernung ermöglicht wurde. 2014 wurde zusätzlich zum veränderten Fahrzeugaufbau ein Solarmodul installiert. Dieses lud die Batterie während der Fahrt mit max. 20% des Verbrauchs. Trotz des zusätzlichen Gewichts konnte dadurch eine weitere Verbesserung des Verbrauchs erreicht werden.

	2010	2011	2013	2016
Fahrzeug	LaDy	LaDy II	LaDy 3	LaDy H2
Energy	H2	H2	H2	H2
Beste Wertung km/kWh	148	236	331	188
entspricht km/l	1321	2098	2943	1604

An den Ergebnissen ist erkennbar, dass durch die Veränderungen der Fahrzeugkonstruktion von 2010 auf 2011 eine Reichweitensteigerung ermöglicht werden konnte. Anschließend folgten Veränderungen am Energiemanagement, die ebenfalls zu einer Steigerung der Reichweite führten. Bis einschließlich 2015 wurden die Testfahrten auf einer nahezu ebenen

Strecke durchgeführt. Im Jahr 2016 wurde eine Teststrecke mit einer Steigung von 15% gewählt. Diese Veränderung ermöglichte realere Testbedingungen. Damit bestätigte sich, dass neben der Optimierung des Fahrwiderstands in den Jahren 2008 bis 2012 das Energiemanagement eine entscheidende Größe für ein energieeffizientes Fahrzeug ist.



Abbildung 1: Ergebnisse Lausitz Dynamics

Die zwei Umwandlungen – elektrochemische Reaktion in der Brennstoffzelle und die anschließende elektromechanische Nutzung der gewonnenen Energie – haben ein geringeres Wertungsergebnis zur Folge. Demnach kann ein Brennstoffzellenfahrzeug bei gleichen Ausgangsbedingungen nie den gleichen Systemwirkungsgrad wie ein batteriebetriebenes Fahrzeug erreichen.

Ermöglicht wurden diese Forschungen durch materielle und finanzielle Zuwendungen von externen Partnern sowie den Professorinnen und Professoren des Instituts für „Elektrische Systeme und Energielogistik“ und des Instituts für „Maschinenbau und Management“.

41. The model of economic evaluation use of the capacity intangible resources on the example of Russian regions

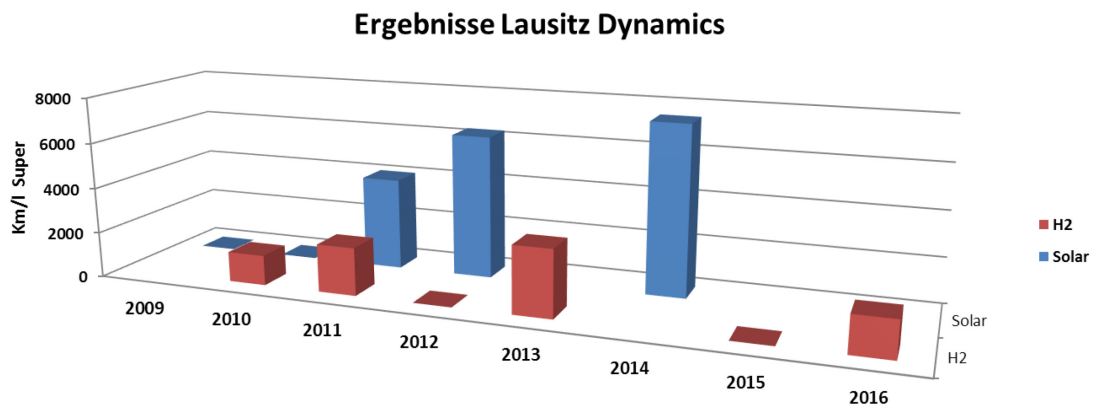
E. Mikhalkina¹, N. Kosolapova¹, D.Mikhalkina¹

Abstract: The article presents the problem of assessing the potential use of intangible resources. The relevance of the research is determined by the necessity of innovation-based economy, the growing role of intangible resources (human, social, organizational, intellectual and other kinds of capital) in promoting economic development of individual regions and the country as a whole. The paper proposes a verification method of the factors that characterize the potential use of intangible resources, affecting productivity. For a description of dependencies linear regression model was selected, also there was carried out an assessment of its parameters and performed Quality check of model. A result of analyzing the primary data provided by the State Statistics Committee of Russia been proved that the volume of innovative products, works and services has a positive effect on productivity, as a main indicator of the result of innovation and economic growth.

Keywords: intangible resources, potential assessment model of capacity intangible resource.

In modern economy, the share of intangible resources significantly increases at the level of companies and the economy as a whole.

Intangible resources - part of the company potential, bringing economic benefit in the long run and has an intangible basis of the income generation. Intangible resources include industrial and intellectual property; human resources, including knowledge, skills, skills that can't be separated from the carrier; intellectual resources of society or the organization (patents, licenses, technology, innovative equipment, etc.); information resource and communication systems; organizational resource (corporate culture, social interaction technology, training and development system); social capital. The notion of "intangible assets" in the accounting records includes objects of intellectual property and rights to them (the right of the patent holder on invention, industrial design, utility model, a computer program, a database the trademark and service mark, selection results, etc.). The intangible resources of the national economy also include national brand. Currently, in developed countries such intangible assets as brands, people, different know-how, relationships with customers, in-house social and labor relations, etc., make up for most companies a larger share of their total value than tangible assets, such as equipment and infrastructure. Establishment of intangible assets and their effective management - the key to success in the long term. Effective non-material resources management is based, on the one hand, on an assessment of their effective use, and on the other - on the sources of funding and their structure. The criteria of effectiveness, for example, scientific researches and developments, represented in the information and statistical digest FGBNU SRI RINKTSE, are different indicators of patent activity – obtaining of patent applications and patents granted for inventions and utility models, also which were issued in Russia by sections of the International Patent Classification (IPC); indicators of technological exchange - licenses and technology trade

with foreign countries; creation and use indicators of advanced production technology and other.

Another major component of effective management of intangible assets is finding funding sources of scientific sphere. In modern situation financing sources are represented mostly by two groups - budgetary and extrabudgetary funds. In the leading countries from 12 to 75% expenditures on science are financed from the state budget. Currently the share of budgetary financing is 67.1% in Russia. Funds of all levels budgets (the federal budget, the budgets of the RF subjects and local budgets), budgetary allocations for maintenance of educational institutions of higher education and tools public sector organization facilities belong to budget funds. The own funds of research organizations, extrabudgetary, business sector organizations funds, higher education institutions, private non-profit organizations and foreign sources are extrabudgetary sources.

The innovation type of economic development is possible with a high level of knowledge and culture accumulation, improve the quality of professional competence, the development of organizational culture and so forth.

Investigating the role of non-material component of economic growth, exactly non-material resources, human and intellectual capital, social resources seems urgent, especially in the identification and analysis of factors determining their development and impact on productivity.

As indicators of characterizing the formation of intangible resource areas will be considered:

Designation	Indicator name
X ₁	The number of patents granted
X ₂	Advanced manufacturing technologies that are used in the Russian Federation subjects (units)
X ₃	The volume of innovative products, works and services for the subjects of the Russian Federation (mln. Rubles)
X ₄	A special costs associated with environmental innovations by regions of the Russian Federation (mln. Rubles)
X ₅	The number of staff, which is take part in researches and developments by regions of the Russian Federation (the man)
X ₆	Intramural expenditures of researches and developments in the Russian Federation subjects (mln. Rub.)
X ₇	The number of researchers with a scientific degree by regions of the Russian Federation
X ₈	The number of graduate students in the Russian Federation subjects (people)
X ₉	The number of doctoral students in the Russian Federation subjects (people)
X ₁₀	The economically active population by regions of the the Russian Federation, on average per year (thous. Persons)
X ₁₁	The number of educational institutions of higher professional education

The study of the socio-economic indicators effect characterizing non-material resources, human and intellectual capital, social resources on labor productivity is possible with the use of regression analysis methods.

On the basis of the above data rates the linear and nonlinear models of labor productivity were constructed and analyzed. As a result of exploring, it was

determined that the best results are given by the linear model. In general linear regression model can be written:

$$y = f(x) + u = b_0 + b_1x_1 + b_2x_2 + \dots + b_mx_m + \varepsilon$$

y - dependent, the resulting variable model;

x_1, x_2, \dots, x_m - independent, exogenous variables, signs factors or regressors;

$b_0, b_1, b_2, \dots, b_m$ - model parameters;

ε - random member, random component or model error.

The evaluation process assumes performance sequence of steps to evaluate its options and checking the quality of the constructed model. The main steps of building a regression model are:

- The construction of indicators system (factors). Data collection and preliminary analysis of the original data. Calculation of the correlation coefficient.
- Selection the model and numerical estimation of its parameters.
- Quality check of model.
- Assessing the impact of individual factors on the basis of the model.

The construction of a regression model reduces to the evaluation and interpretation of its parameters. The construction of a regression model reduces to the evaluation and interpretation of its parameters. One of the possible estimation parameter is the method of least squares (OLS), which minimizes the sum of squared deviations of actual and estimated values of resultant variable.

The exercise of these steps allowed us to obtain the following regression equation:

$$\hat{Y} = 342,87 - 2,3 x_1 + 0,72 x_3 + 0,558 x_4 + 2,44 x_7$$

t- statistics (-3,203) (4,055) (5,001) (2,183)

$R^2 = 0,73$ DW=1,44

The equation obtained rather adequately ($R^2 = 0.73$), significantly for F-criterion (Ffakt. = 9.53), significant in the equation are the coefficients of the variables x_1, x_3, x_4, x_7 . From the obtained model implies that the following factors substantially influenced on labor productivity:

x_1 - the number of patents granted, the impact of this indicator is negative, because the number of issued patents is due to an increase of labor input, considerable time investments (clearance of innovation results, registration and other activities directly related to the legal authorization of the copyright takes a considerable amount of time), which in turn leads to a decrease in labor productivity;

x_3 - the volume of innovative products, works and services in regions of the Russian Federation, increase of the innovative products volume of 1% leads to increase labor productivity by an average of 0.72 units;

x_4 - special costs associated with environmental innovations in the Russian Federation subjects, the impact of this factor is positive, its increase of 1% would lead in the mean to increase in labor productivity at 0.558 U .;

x_7 - increase the number of researchers with a scientific degree, in the Russian Federation subjects, of 1% will lead to increase in productivity by an average of 2.44 units.

The volume of innovative products, works and services has a positive effect on labor productivity, as the main outcome measure of innovation. The success of the region innovative development depends on the level of innovative technologies development. And also its ability to innovate, implement

innovations and thus increase the volume of innovative products, works and services. The region's ability to produce enough innovative products indicates attractive investment environment, developed an innovative and industrial infrastructure, which in turn has a positive effect on productivity.