

Ultrasonic Testing of Adhesively Bonded Joints Using Air-Coupled Cellular Polypropylene Transducers

Mate GAAL¹, Elmar DOHSE¹, Jürgen BARTUSCH¹, Enrico KÖPPE¹,
Marc KREUTZBRUCK¹, Wolfgang HILLGER², Jay AMOS³

¹ BAM Federal Institute for Materials Research and Testing, Berlin, Germany
Phone: +49 30 8104 3174, Fax: +49 30 8104 1845; e-mail: mate.gaal@bam.de

² Ingenieur-Büro Dr. Hillger, Braunschweig, Germany; e-mail: hillger@dr-hillger.de

³ Cessna Aircraft, Wichita, Kansas, USA; e-mail: jmamos@cessna.textron.com

Abstract

In air-coupled ultrasonic testing, the impedance mismatch between the transducer and the air is commonly being solved by adding matching layers to composite transducers. To avoid the difficult technological procedure regarding matching layers, some new piezoelectric materials have been proposed. Most promising are ferroelectrets, which are charged cellular polymers, having ferroelectric and consequently piezoelectric properties. In particular, the extreme softness of cellular polypropylene (cPP) leads to a high piezoelectric constant and to a good impedance match with the air, making matching layers redundant. Its elasticity modulus below 1 MPa causes an additional effect not observed with common piezoelectric materials: that is the electrostrictive effect, here defined as the thickness change due to the attractive force between the transducer electrodes. This effect exceeds the piezoelectric effect at excitation voltages over 1 kV. The extreme softness of cPP leads also to high flexibility, enabling easy focusing by bending the transducer.

We have developed air-coupled ultrasonic transducers based on cPP. This includes the electrical matching networks for the transmitter and for the receiver. The transmitter is excited with voltages up to 2.5 kV, so that the electrostrictive effect dominates, leading to sound pressure around 145dB at the transducer surface. These transducers have been applied for testing carbon-fiber-reinforced polymer plates, adhesive joints and other composite structures. Here we report about ultrasonic transmission of two types of adhesive joints. The first one is multi-layer aluminium components with some artificial disbonds, which are common in aerospace industry, and the second one is an aluminium-steel joint with polyurethane adhesive, which is used in automotive industry.

Keywords: air-coupled, ultrasonic testing, ferroelectret, cellular polypropylene, transducer, adhesive joint

1. Cellular polypropylene transducers for air-coupled ultrasonic testing

When a fluid couplant may damage the inspected object, air-coupled ultrasonic testing (ACUT) is often the most suitable inspection method [1,2]. A typical application of ACUT is on carbon-fibre- and glass-fibre-reinforced plastics, which are increasingly used in aerospace and automotive industry [3]. A new application of ACUT is inspection of adhesive joints. Commercially available high sensitivity air-coupled transducers consist of a piezoelectric ceramic or a composite and several matching layers reducing the impedance mismatch between the transducer and the air. However, matching layers are cumbersome to produce and they reduce the transducer bandwidth, which downgrades the time resolution [4]. These difficulties would be avoided by using a transducer with a low acoustic impedance and yet with good piezoelectric properties. The most promising material in this respect is charged cellular polypropylene (cPP) with an acoustic impedance of about 0.026 MRayl and a piezoelectric constant d_{33} between 90 and 250 pC/N [5-7]. Its voids are polarized by subjecting the material to a high electric field. Such polymer foams carrying positive and negative charges on opposite internal void surfaces are called ferroelectrets.

Due to its cellular structure, cPP has an extremely low elasticity modulus between 0.1 and 1 MPa. This causes an additional effect not observed with common piezoelectric materials: that is the electrostrictive effect, here defined as the thickness change due to the attractive force between the transducer electrodes [8,9]. This effect exceeds the piezoelectric effect at excitation voltages over 1 kV.

A cPP ferroelectret transducer was developed for ultrasonic non-destructive testing [8-12]. Transducer electrodes were deposited on front and rear faces of cPP ferroelectret by means of physical vapour deposition [13]. In order to avoid any plasma and thermal damage of the ferroelectret, electron beam evaporation at room temperature was selected as deposition technique. The electrode configuration consists of a 200 nm aluminium layer on a 5 nm chrome film acting as seed layer to improve adhesion of the layer stack. The electrical matching network for the receiver contains an ultra-low-noise preamplifier, whereas the electrical matching of the transmitter provides excitation pulses of 2.5 kV (patent pending) [14]. At these voltages the electrostrictive effect prevails, leading to sound pressure of about 145dB at the surface of a single-layer transducer. These planar transducers including the electrical matching networks were developed in a joint project between Federal Institute for Materials Research and Testing (BAM) in Berlin and “Ingenieur-Büro Dr. Hillger” in Brunswick, Germany (Fig. 1). Recently, up to four layers of cPP were glued together using a low-viscosity adhesive to lower the resonance frequency down to 75 kHz.

Based on experiences with planar cPP transducers, we (BAM) developed the first prototypes of spherically focused cPP transducers. Two cPP films with a diameter 19 mm were bent with curvature radii 60 and 50 mm.

In this paper we report about ultrasonic transmission of two types of adhesive joints. The first one is multi-layer aluminium components with some artificial disbonds, which are common in aerospace industry, and the second one is an aluminium-steel joint with polyurethane adhesive, which is used in automotive industry. They were inspected using planar and focused transducers based on cPP.



Fig. 1. Transducer based on cellular polypropylene. One module (left) contains the piezoelectric material with electrodes, whereas the other module (right) contains the electric matching network, either for the transmitter or for the receiver.

2. Test blocks and inspection setup

2.1 Multi-layer aluminium components

Three adhesively bonded aluminium components were prepared at Cessna to represent potential bond voids encountered in the aerospace industry (Fig. 2). The engineered flaws represent weak bonds or voids due to lack of adhesion, having a size ranging from 13x13 mm to 17.8x17.8 mm. The weak bonds were created by layers of release film inserts, creating air gaps and preventing adhesion. The adhesive applied was a common epoxy film using a standard cure cycle.

- a) AVP1005A is a step wedge consisting of seven steps, each with multiple adhesively bonded aluminum layers and inserted flaws at various layer interfaces.
- b) WPS400-187B is a sandwich structure consisting of an aluminum honeycomb adhesively bonded between two double-layered aluminum face sheets. The flaws consist of missing adhesive between the core and the face sheets.
- c) WPS400-137-138 is an aluminum plate with adhesively bonded angle and T-stringers containing flaws at various layer interfaces.

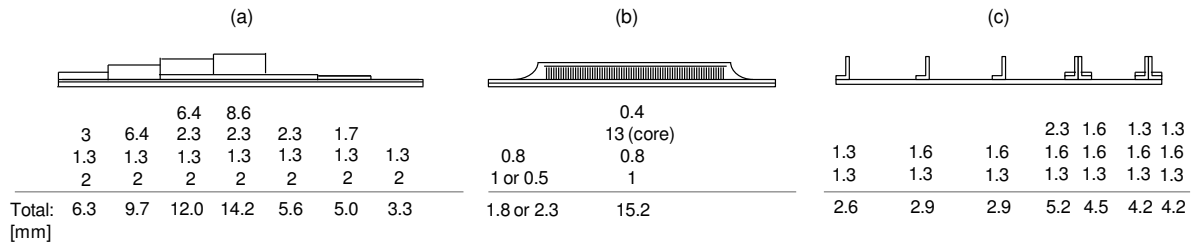

Fig. 2. Adhesively bonded aluminium components with built-in flaws, with indicated layer thicknesses in mm. (a) Step wedge AVP1005A, (b) honeycomb sandwich WPS400-187B, and (c) stringers WPS400-137-138, drawings not in scale.

These test probes were inspected using ACUT transmission with 0° incidence angle. The applied transducers were focusing cPP transducers at 250 kHz developed at BAM. The transmitter and the receiver had a curvature radius of 60 and 50 mm respectively and a calculated focal distance 36 and 33 mm respectively. Additionally, an excerpt of AVP1005A was inspected with a three-layered planar transducer with a resonance frequency 90 kHz and a focal length 22 mm. The distance to the test block was equal to the respective focal length of the applied transducer. For the inspection of test block AVP1005A the distance was adjusted to the thickest joint. The inspection was performed with USPC 4000 AirTech, an ultrasonic device for air-coupled testing. The index resolution was 0.5 mm.

2.2 Aluminium-steel joint

An adhesively bonded omega stringer with aluminium and steel components was prepared to represent potential bond voids encountered in the automotive industry (Fig. 3). The engineered flaws represent weak bonds or voids due to lack of adhesion, having different sizes, as shown in (Fig. 4). The adhesive applied was polyurethane BF2850.

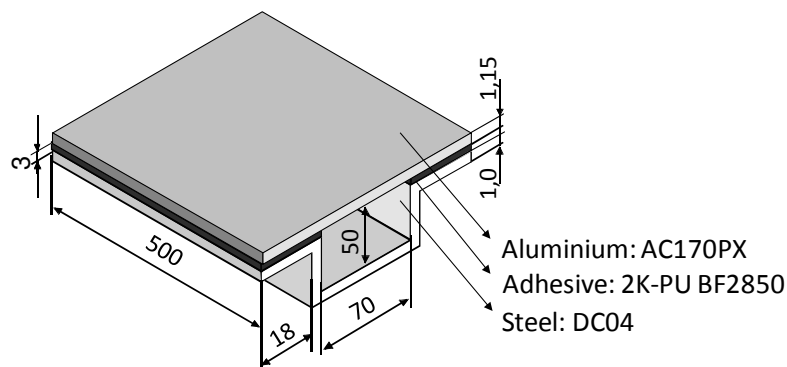

Fig. 3. Adhesively bonded omega stringer with an aluminium-steel joint. Measures in mm, drawing not in scale.

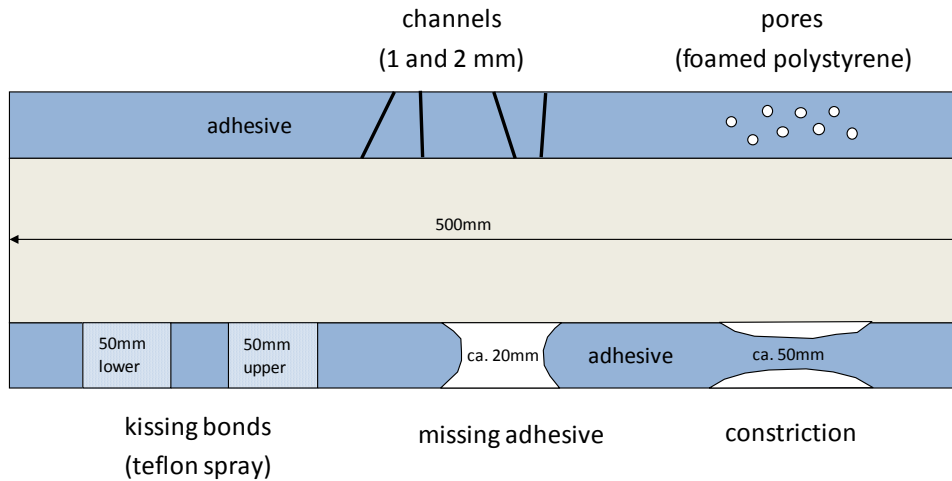

Fig. 4. Engineered flaws in the adhesively bonded omega stringer, top view, drawing not in scale.

The omega stringer was inspected using ACUT transmission with 0° incidence angle with polypropylene transducers at 250 kHz. A focusing transducer was applied as a receiver at the upper (aluminium skin) side and a planar transducer as a transmitter at the lower (steel) side. The focusing transducer had a curvature radius of 60 mm and a calculated focal distance of 36 mm. The distance to the test block was equal to the respective focal length of the applied transducer. The short focal distance of the focussing transducers limits the accessibility from the lower side, which was the only reason to use a planar transducer. The inspection was performed with USPC 4000 AirTech, an ultrasonic device for air-coupled testing. The index resolution was 0.2 mm.

2. Inspection results

2.1 Multi-layer aluminium plates

2.2.1 Step wedge

Figures 5, 6 and 7 are the results of the inspection on the step wedge AVP1005A. The indications in the upper corners on the first two images come from the fixture. All flaws were found with ACUT. The indications of flaws in the fourth, thickest step have a signal-to-noise ratio (SNR) about 3 dB. To improve the SNR we have scanned the middle row with planar cPP transducers consisting of three layers of cPP films, therefore having a resonance frequency of 90 kHz. The results in Fig. 7 show that the flaw in the thickest step is much more visible with a SNR about 12 dB, because the signal transmitting the healthy part of the plate is higher, but the flaw in the third step became less visible. However, the lateral resolution is poorer, because this planar transducer has a focus diameter of about 5 mm, compared to the focal size of about 3 mm for the focusing transducers.

The same test block was inspected using squirter jet technique [15]. The probes had a frequency of 2.25 MHz and a diameter of 19 mm. The index resolution was 2 mm using squirter nozzle diameters of 4.8 mm with nozzle water path distance of 230 mm. The resulting C-Scan (Fig. 6) shows that splashing noise creates unsteady coupling conditions leading to possible false alarms. Four of the flaws were missed using this technique.

2.2.2 Sandwich with a honeycomb core

The sandwich test block with a honeycomb core was inspected with two different gains. The results of C-Scans are presented in Figures 8 and 9, with Fig. 8 presenting only a segment of the test block. The lower gain was adjusted to detect the flaws in the edge part (Fig. 8), while the higher gain was optimized for the inspection of the middle part, with flaws between the core and the skin (Fig. 9). All flaws are clearly visible.

2.2.3 Stringers

The measurements on stringers WPS400-137-138 are shown in Fig. 10. All flaws were found. The C-Scan image is actually a result of two separate scans, which were joined into one image at $y = 95$ mm.

2.2 Aluminium-steel joint

All flaws in the aluminium-steel joints of the omega stringer were detected, except for the kissing bonds. The missing adhesive and the constriction of the adherent are especially clearly visible (Fig. 11 (b) around $y=250$ and 400 mm respectively). Even the 1 mm thick channels and the pores were all detected (Fig. 11 (a) around $y=250$ and 400 mm respectively). The signal might be slightly reduced at the location of emulated kissing bonds (Fig. 11 (b) around $y=100$ mm), but this reduction is not sufficient for their unambiguous detection.

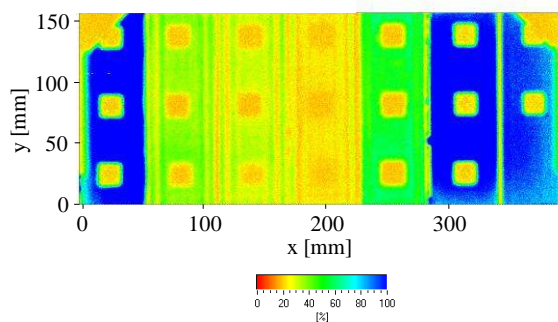

Fig. 5. Step wedge AVP1005A, air-coupled ultrasonic inspection with 250 kHz focusing transducers.

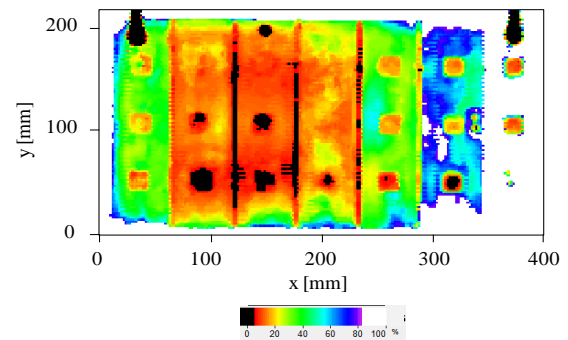

Fig. 6. Step wedge AVP1005A, squirter jet inspection.

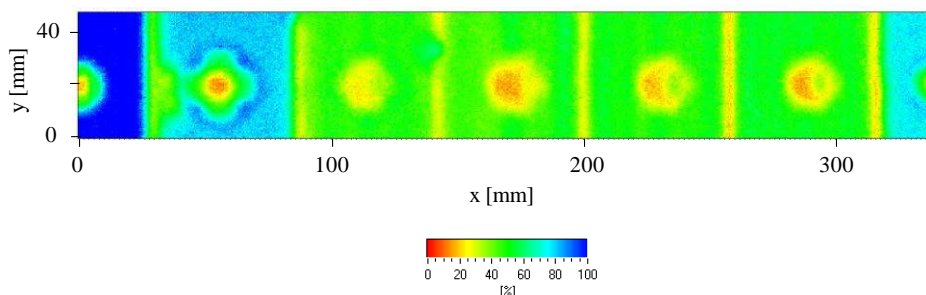

Fig. 7. Step wedge AVP1005A, the middle segment, air-coupled ultrasonic inspection with 90 kHz planar transducers.

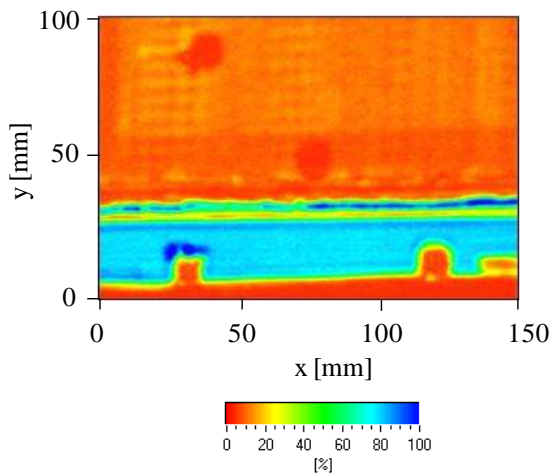

Fig. 8. Sandwich structure with honeycomb, lower edge of WPS400-187B, air-coupled ultrasonic inspection with 250 kHz focusing transducers.

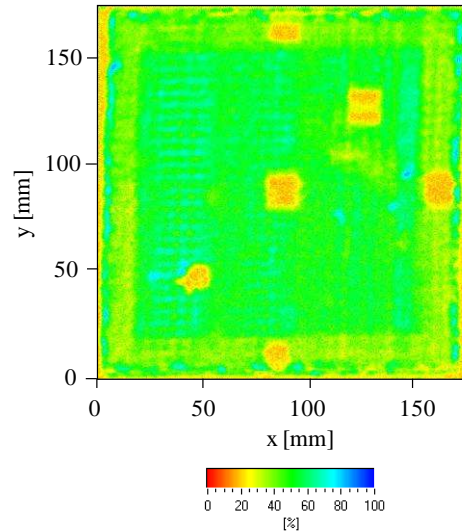

Fig. 9. Sandwich structure with honeycomb, the middle segment of WPS400-187B containing the honeycomb core, air-coupled ultrasonic inspection with 250 kHz focusing transducers.

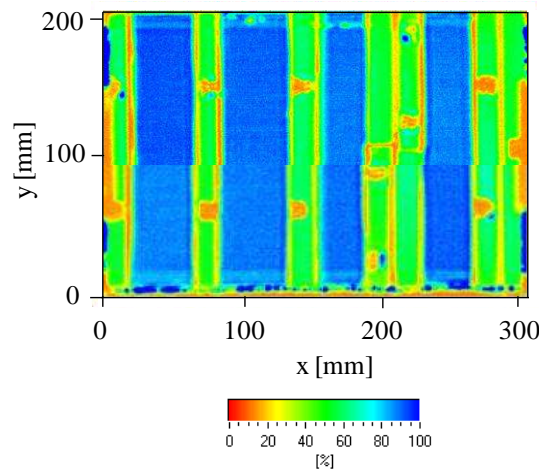

Fig. 10. Stringers WPS400-137-138, air-coupled ultrasonic inspection with 250 kHz focusing transducers.

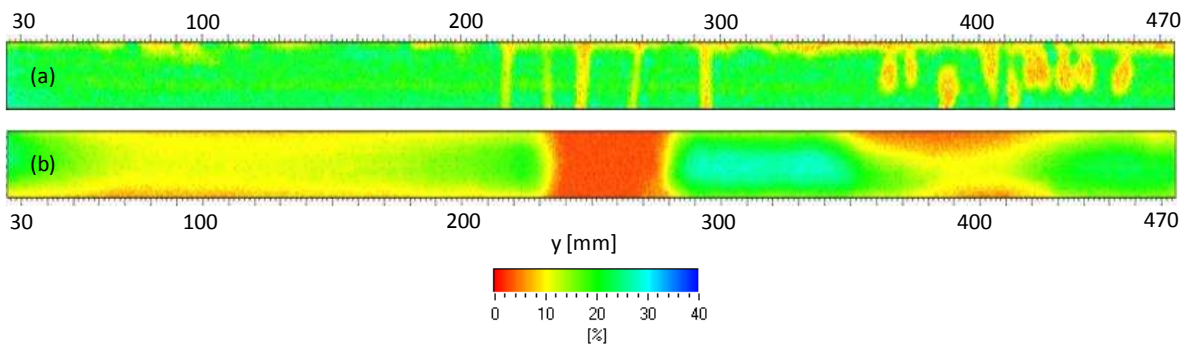

Fig. 11. Aluminium-steel joints of the omega stringer, air-coupled ultrasonic inspection with 250 kHz focusing transducers. Joint (a) contained channels and pores, whereas joint (b) contained kissing bonds, missing adhesive and constriction of adherent.

3. Discussion and conclusions

Transmission inspection using ACUT can be effectively used to detect most typical flaws in adhesive joints. The smallest detected flaws were channels with a diameter of 1 mm. They were detected with a 250 kHz planar transmitter and a focussing transducer as a receiver. The diameter of the sound beam at the focal distance of the focussing transducer was 3 mm. Interestingly, the detected flaws were three times smaller than the focus diameter. The emulated kissing bonds in the omega stringer could not be unambiguously detected.

The transducer frequency needs to be adjusted to the sample thickness to maximize the signal. A comparison of Figures 7 and 5 shows that the choice of lower frequency (90 kHz compared to 250 kHz) improved the image of the thickest step. The image with 90 kHz has a lower lateral resolution because it was done with a planar transducer. This demonstrates the benefits of focusing.

The scan velocity of ACUT is typically limited by the air travel time and by guided waves, which both create ghost echoes. The pulse repetition frequency (PRF) in our experiments was limited to 200. With 2 x 2 mm index resolution, ACUT can be performed at scanner speed ~400 mm/s, which gives the same or slightly less scanner throughput as squitter jet inspection (SJUT) [15]. However, ACUT offers the advantage of easier application without the maintenance issues of water filtration, algae control, handling facilities, and safety concerns, nor any potential contamination concerns for some sensitive composite assemblies.

Further advantage of ACUT compared to contact techniques is a more homogeneous signal, which is a result of stable coupling conditions, provided there is no strong airflow. Compared to SJUT, this enhances the visibility of flaws through a higher SNR. As a result of these differences, four difficult flaws in the step wedge were missed by SJUT inspection at a particular frequency (Fig. 6), whereas all of them were found by ACUT (Fig. 5).

The main difficulty of ACUT is a strong reflection from the surface of the tested specimen. This reduces the transmitted signal considerably. It also causes a strong entry echo when pulse echo technique or twin probes are used, resulting in a very long dead zone of several centimetres. This is why the use of ACUT is practically limited to transmission applications, with some rare exceptions in civil engineering. To broaden their field of applications, the future development of air-coupled probes should be directed towards increasing not only their sensitivity, but also their bandwidth, which would facilitate inspection of components with single-sided accessibility much required by the airspace and automotive industry. For such components, air-coupled detection of guided waves is also a promising technique.

ACUT offers many advantages compared to conventional contact techniques or SJUT. The coupling is more uniform, which enhances the resolution and the probability of detection, and the maintenance is easier. Therefore, ACUT can be seen as an attractive alternative for testing metal adhesively bonded joints for aerospace and automotive industry.

4. Acknowledgements

This work was partially funded by the German Federal Ministry of Economy and Energy.

References

1. M. C. Bhardwaj, "Non-Destructive Evaluation: Introduction of Non-Contact Ultrasound", in *Encyclopedia of Smart Materials*, edited by M. Schwartz, John Wiley & Sons, New York, 2001, pp. 690-714.
2. J. Krautkrämer and H. Krautkrämer, *Ultrasonic testing of materials*, Springer, 1990.
3. W. Hillger, F. Meier and R. Henrich, "Inspection of CFRP components by ultrasonic imaging with air coupling" in *Proceedings of the 8th European Conference of Nondestructive Testing ECNDT*, Barcelona, 17-21 June 2002.
4. G. S. Kino, *Acoustic Waves*, Prentice-Hall, New Jersey, 1993.
5. M. Paajanen, J. Leikkala and K. Kirjavainen, *Sensors and Actuators* **84**, pp. 95-102 (1999).
6. S. Bauer, R. Gerhard-Multhaupt and G. M. Sessler, *Phys. Today* **57**, pp. 37-43 (2004).
7. M. Wegener, R. Gerhard-Multhaupt, M. Dansachmüller, R. Schwödiauer, S. Bauer-Gogonea, S. Bauer, M. Paajanen, H. Minkkinen, and J. Raukola, *Appl. Phys. Lett.* **84**, pp. 392-394 (2004).
8. J. Döring, V. Bovtun, J. Bartusch, A. Erhard, M. Kreutzbruck, Y. Yakymenko, *Appl. Phys. A* **100**(2), pp. 479-485 (2010).
9. J. Döring, V. Bovtun, M. Gaal, J. Bartusch, A. Erhard, M. Kreutzbruck and Y. Yakymenko, *J. Appl. Phys.* **112**, 084505 (2012).
10. V. Bovtun, J. Döring, J. Bartusch, U. Beck, A. Erhard, Y. Yakymenko, *Appl. Phys. A* **88**, pp. 737-743 (2007).
11. V. Bovtun, J. Döring, J. Bartusch, M. Gaal, A. Erhard, M. Kreutzbruck, Y. Yakymenko, *Advances in Applied Ceramics* **111** (2012).
12. J. Döring, M. Gaal, J. Bartusch, M. Kreutzbruck, A. Erhard and V. Bovtun, *Materials Testing* **55**, pp. 96-102 (2013)
13. M. Gaal, J. Döring, J. Bartusch, U. Beck, M. Weise, V. Bovtun, G. Brekow and M. Kreutzbruck, "Parameter Reproducibility of Polypropylene Ferroelectret Transducers for Air-Coupled Ultrasonic Testing", in *Proceedings of IEEE International Ultrasonics Symposium*, Orlando, Florida, USA, 18-21 Oct. 2011.
14. M. Gaal, J. Döring, J. Bartusch, T. Lange, W. Hillger, G. Brekow and M. Kreutzbruck, "Ferroelectret Transducers for Air-Coupled Ultrasonic Testing of Fiber-Reinforced Polymers", in *Proceedings of QNDE – Review of Progress in Quantitative Nondestructive Evaluation*, Denver, Colorado, USA, 15-20 July 2012.
15. M. Gaal, J. Bartusch, E. Dohse, M. Kreutzbruck and J. Amos, "Air-Coupled Ultrasonic Testing of Metal Adhesively Bonded Joints Using Cellular Polypropylene Transducers", in *Proceedings of QNDE – Review of Progress in Quantitative Nondestructive Evaluation*, Baltimore, Maryland, USA, 15-19 July 2013.